

Clean, Dry Compressed Air Vacuum Regeneration

WVM Generation 5

WVM 45 ~ WVM 750

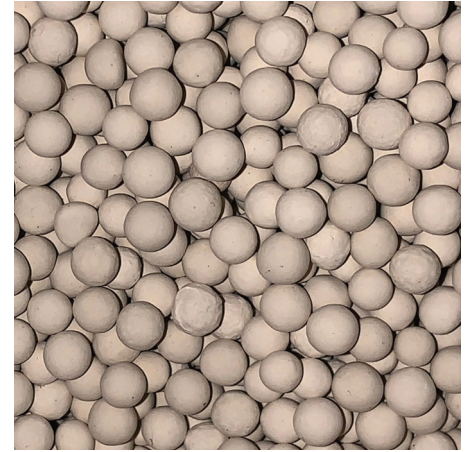

Adsorption Dryers

Whether a compressed air user wants to control the growth of micro-organisms (essential for direct and in-direct contact applications in the food, beverage & pharmaceutical industries), ensure air used for critical applications / instrumentation is free from water contamination or has external piping where low ambient temperature can cause condensation, adsorption dryers are the go to dryer technology.

There are many different adsorption dryer technologies available and whilst they all reduce water from the compressed air in the same way, they differ in the way they regenerate the desiccant material.

Vacuum Regeneration Adsorption Dryers

Vacuum regeneration dryers do not use process air to regenerate the adsorbent desiccant material, instead they use ambient air for both regeneration and cooling (reducing energy consumption and process air loss).

For regeneration, the ambient air is heated and pulled across the desiccant bed using a vacuum pump. To cool the desiccant and ensure it is at the optimum temperature for adsorption, the heat source is simply removed, and the desiccant cooled to ambient temperature.

Vacuum regeneration dryers can be supplied with electric heaters or heat exchangers that utilise existing heat sources on site (steam, hot oil, etc.)



Advantages

- Parker WVM dryers provide a constant outlet dewpoint in accordance with ISO8573-1 classes 1, 2 or 3 for water vapour & -25°C PDP
- Air quality is enhanced when installed with Parker OIL-X General Purpose & High Efficiency Coalescing pre-filtration and General Purpose Dry Particulate post filtration
- No process air is used during regeneration & cooling of the desiccant material, reducing energy consumption
- Regeneration under vacuum further improves energy efficiency
- Can utilise existing heat sources (eliminating need for electrical heater) to further reduce energy consumption - Options for Steam Only Heat Exchanger or Steam + Electric Heat Exchanger in place of electric heater
- Full feature electronic control with dewpoint display and Energy Saving Technology fitted as standard
- Large flow capacities



ENGINEERING YOUR SUCCESS.

Dryer Performance

Dryer Models	Dewpoint (Standard)		ISO8573-1:2010 Classification (Standard)	Dewpoint (Option 1)		ISO8573-1:2010 Classification (Option 1)	Dewpoint (Option 2)		ISO8573-1:2010 Classification (Option 2)
	°C	°F		°C	°F		°C	°F	
WVM	-40	-40	Class 2.2.2	-70	-100	Class 2.1.2	-20	-4	Class 2.3.2

ISO8573-1 Classifications when used with Parker domnick hunter OIL-X pre / post filtration

Technical Data

Dryer Models	Minimum Operating Pressure		Maximum Operating Pressure		Minimum Operating Temperature		Maximum Operating Temperature		Maximum Ambient Temperature		Electrical Supply (Standard)	Electrical Supply (Optional)	Thread Type	Noise Level dB(A)
	bar g	psi g	bar g	psi g	°C	°F	°C	°F	°C	°F				
WVM	4	58	11	145	5	41	40	104	40	104	400V 3ph 50Hz	On request	DIN Flange	80-85

Flow Rates

Model	Pipe Size	Inlet Flow Rate				Average Power kW
		L/s	m³/min	m³/hr	cfm	
WVM 45	DN 50	125	7.5	450	265	3.6
WVM 60	DN 50	169	10.2	610	359	5.3
WVM 80	DN 50	222	13.4	800	471	6.8
WVM 125	DN 80	325	19.5	1170	689	9.5
WVM 155	DN 80	408	24.5	1470	865	12.8
WVM 210	DN 80	569	34.2	2050	1207	16.8
WVM 310	DN 100	847	50.9	3050	1795	25.4
WVM 370	DN 100	1028	61.8	3700	2178	30.8
WVM 520	DN 150	1403	84.3	5050	2972	41.8
WVM 615	DN 150	1681	101.0	6050	3561	52.6
WVM 750	DN 150	2028	121.9	7300	4297	59.5

Stated flows are referred to to 20°C, 1 bar (a) and 0% relative humidity. These flow rates are for operation at 7 bar (g) (102 psi g), 35°C dryer inlet temperature and 100% relative humidity. Ambient temperature 25°C and 60% relative humidity. For flows at other pressures, apply the correction factors shown below.

Product Selection & Correction Factors

For correct operation, compressed air dryers must be sized using for the maximum (summer) inlet temperature, maximum (summer) ambient temperature, minimum inlet pressure, required outlet dewpoint and maximum flow rate of the installation.

To select a dryer, first calculate the MDC (Minimum Drying Capacity) using the formula below then select a dryer from the flow rate table above with a flow rate equal to or above the MDC.

Minimum Drying Capacity = System Flow x CFMIT x CFMAT x CFMIP x CFOD

CFMIT - Correction Factor Maximum Inlet Temperature

Maximum Inlet Temperature	°C	25	30	35	40
	°F	77	86	95	104
Correction Factor		0.80	0.91	1.00	1.80

CFAT - Correction Factor Maximum Ambient Temperature

Maximum Ambient Temperature	°C	20	25	30	35	40	45	50
	°F	68	77	86	95	104	113	122
Correction Factor		1.00	1.00	1.00	1.00	1.00	1.00	1.00

CFMIP - Correction Factor Minimum Inlet Pressure

Minimum Inlet Pressure	bar g	4	5	6	7	8	9	10	11
	psi g	58	73	87	100	116	131	145	160
Correction Factor		2.00	1.39	1.18	1.00	0.99	0.87	0.79	0.56

CFOD - Correction Factor Outlet Dewpoint

Outlet Dewpoint	°C	-20	-25	-40	-70
	°F	-4	-13	-40	-100
Correction Factor		0.95	0.95	1.00	*

*For -70°C PDP Dewpoint Selection - Please Contact Parker GSFE Division

Controller Basic Functions^{*)}

Dryer	Controller Function							
	Power On Indication	Visual Fault Indication	Dewpoint Display	EST - Energy Saving Technology	Filter Service Indicator	Dryer Service Indicator	Fault Relay: Power Loss Dewpoint Alarm Sensor Failure	4-20mA Dewpoint Re-transmission
WVM	•	•	•	•		•	•	•

^{*)}To know all the controller features, please contact Parker GSFE Division.

Required Filtration

Model	Pipe Size	Dryer Inlet		Dryer Outlet		
		General Purpose Pre-filter	High Efficiency Filter	Oil Vapour Reduction Filter	General Purpose Dry Particulate Filter	High Efficiency Dry Particulate Filter
WVM 45	DN 50	AOP035GGFX	AAP035GGFX	-	AOP035GGMX	-
WVM 60	DN 50	AOP040HGFX	AAP040HGFX	-	AOP040HGMX	-
WVM 80	DN 50	AOP045IGFX	AAP045IGFX	-	AOP045IGMX	-
WVM 125	DN 80	AO065NDEX	AA065NDEX	-	AO065NDMX	-
WVM 155	DN 80	AO065NDEX	AA065NDEX	-	AO065NDMX	-
WVM 210	DN 80	AO065NDEX	AA065NDEX	-	AO065NDMX	-
WVM 310	DN 100	AO070ODEX	AA070ODEX	-	AO070ODMX	-
WVM 370	DN 100	AO070ODEX	AA070ODEX	-	AO070ODMX	-
WVM 520	DN 150	AO075PDEX	AA075PDEX	-	AO075PDMX	-
WVM 615	DN 150	AO075PDEX	AA075PDEX	-	AO075PDMX	-
WVM 750	DN 150	AO080PDEX	AA080PDEX	-	AO080PDMX	-

Filtration Performance	General Purpose Pre-filter	High Efficiency Filter	Oil Vapour Reduction Filter	General Purpose Dry Particulate Filter	High Efficiency Dry Particulate Filter
Filtration Grade	Grade AO	Grade AA	-	Grade AO	-
Filtration Type	Coalescing	Coalescing	-	Dry Particulate	-
Particle Reduction (inc water & oil aerosols)	Down to 1 micron	Down to 0.01 micron	-	Down to 1 micron	-
Maximum Remaining Oil Aerosol Content at 21°C	≤0.5 mg/m ³ (≤0.5 ppm(w))	≤0.01 mg/m ³ (≤0.01 ppm(w))	-	N/A	-
Maximum Remaining Oil Vapour Content at System Temperature	N/A	N/A	-	N/A	-
Filtration Efficiency	99.925%	99.9999%	-	99.925%	-

Weights & Dimensions

Model	Pipe Size	Dimensions (Dryer Only)						Weight (Dryer Only)	
		Height (H)		Width (W)		Depth (D)		kg	lbs
		mm	ins	mm	ins	mm	ins		
WVM 45	DN 50	1981	78.0	1122	44.2	1219	48.0	715	1573
WVM 60	DN 50	1981	78.0	1122	44.2	1219	48.0	745	1639
WVM 80	DN 50	2331	91.8	1122	44.2	1219	48.0	843	1855
WVM 125	DN 80	2293	90.3	1592	62.7	1412	55.6	1273	2801
WVM 155	DN 80	2493	98.1	1592	62.7	1412	55.6	1383	3043
WVM 210	DN 80	2793	110.0	1652	65.0	1462	57.6	1792	3942
WVM 310	DN 100	2720	107.1	2071	81.5	1702	67.0	2520	5544
WVM 370	DN 100	3020	118.9	2071	81.5	1702	67.0	2810	6182
WVM 520	DN 150	3215	126.6	2500	98.4	1910	75.2	4185	9207
WVM 615	DN 150	3465	136.4	2500	98.4	1910	75.2	4615	10153
WVM 750	DN 150	3455	136.0	2717	107.0	1900	74.8	5255	11561

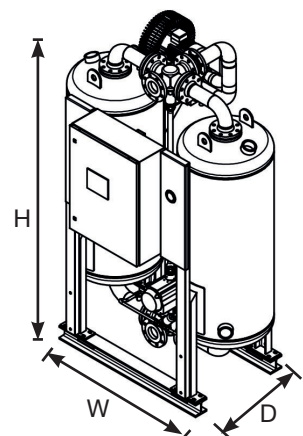

Quality Assurance / IP Rating / Pressure Vessel Approvals

Development / Manufacture	ISO 9001 / ISO 14001 / OSHAS 18001
Ingress Protection Rating	IP54 Indoor Use Only
EU	Pressure vessel approved for fluid group 2 in accordance with the Pressure Equipment Directive 2014/68/EU
USA	Approval to ASME VIII Div. 1 on request
AUS	Approval to AS1210 on request
GUS	TR (formerly GOST-R) on request
For use with Compressed Air and Nitrogen Only	

Parker Worldwide

Europe, Middle East, Africa

AE – United Arab Emirates,
Dubai

Tel: +971 4 8127100
parker.me@parker.com

AT – Austria, St. Florian

Tel: +43 (0)7224 66201
parker.austria@parker.com

AZ – Azerbaijan, Baku

Tel: +994 50 2233 458
parker.azerbaijan@parker.com

BE/NL/LU – Benelux,

Hendrik Ido Ambacht
Tel: +31 (0)541 585 000
parker.nl@parker.com

BG – Bulgaria, Sofia

Tel: +359 2 980 1344
parker.bulgaria@parker.com

BY – Belarus, Minsk

Tel: +48 (0)22 573 24 00
parker.poland@parker.com

CH – Switzerland, Etoy

Tel: +41 (0)21 821 87 00
parker.switzerland@parker.com

CZ – Czech Republic, Klecany

Tel: +420 284 083 111
parker.czechrepublic@parker.com

DE – Germany, Kaarst

Tel: +49 (0)2131 4016 0
parker.germany@parker.com

DK – Denmark, Ballerup

Tel: +45 43 56 04 00
parker.denmark@parker.com

ES – Spain, Madrid

Tel: +34 902 330 001
parker.spain@parker.com

FI – Finland, Vantaa

Tel: +358 (0)20 753 2500
parker.finland@parker.com

FR – France, Contamine s/Arve

Tel: +33 (0)4 50 25 80 25
parker.france@parker.com

GR – Greece, Piraeus

Tel: +30 210 933 6450
parker.greece@parker.com

HU – Hungary, Budaörs

Tel: +36 23 885 470
parker.hungary@parker.com

IE – Ireland, Dublin

Tel: +353 (0)1 466 6370
parker.ireland@parker.com

IL – Israel

Tel: +39 02 45 19 21
parker.israel@parker.com

IT – Italy, Corsico (MI)

Tel: +39 02 45 19 21
parker.italy@parker.com

KZ – Kazakhstan, Almaty

Tel: +7 7273 561 000
parker.easteurope@parker.com

NO – Norway, Asker

Tel: +47 66 75 34 00
parker.norway@parker.com

PL – Poland, Warsaw

Tel: +48 (0)22 573 24 00
parker.poland@parker.com

PT – Portugal

Tel: +351 22 999 7360
parker.portugal@parker.com

RO – Romania, Bucharest

Tel: +40 21 252 1382
parker.romania@parker.com

RU – Russia, Moscow

Tel: +7 495 645-2156
parker.russia@parker.com

SE – Sweden, Spånga

Tel: +46 (0)8 59 79 50 00
parker.sweden@parker.com

SK – Slovakia, Banská Bystrica

Tel: +421 484 162 252
parker.slovakia@parker.com

SL – Slovenia, Novo Mesto

Tel: +386 7 337 6650
parker.slovenia@parker.com

TR – Turkey, Istanbul

Tel: +90 216 4997081
parker.turkey@parker.com

UA – Ukraine, Kiev

Tel: +48 (0)22 573 24 00
parker.poland@parker.com

UK – United Kingdom, Warwick

Tel: +44 (0)1926 317 878
parker.uk@parker.com

ZA – South Africa, Kempton Park

Tel: +27 (0)11 961 0700
parker.southafrica@parker.com

North America

CA – Canada, Milton, Ontario

Tel: +1 905 693 3000

US – USA, Cleveland

Tel: +1 216 896 3000

Asia Pacific

AU – Australia, Castle Hill

Tel: +61 (0)2-9634 7777

CN – China, Shanghai

Tel: +86 21 2899 5000

HK – Hong Kong

Tel: +852 2428 8008

IN – India, Mumbai

Tel: +91 22 6513 7081-85

JP – Japan, Tokyo

Tel: +81 (0)3 6408 3901

KR – South Korea, Seoul

Tel: +82 2 559 0400

MY – Malaysia, Shah Alam

Tel: +60 3 7849 0800

NZ – New Zealand, Mt Wellington

Tel: +64 9 574 1744

SG – Singapore

Tel: +65 6887 6300

TH – Thailand, Bangkok

Tel: +662 186 7000

TW – Taiwan, Taipei

Tel: +886 2 2298 8987

South America

AR – Argentina, Buenos Aires

Tel: +54 3327 44 4129

BR – Brazil, Sao Jose dos Campos

Tel: +55 800 727 5374

CL – Chile, Santiago

Tel: +56 2 623 1216

MX – Mexico, Toluca

Tel: +52 72 2275 4200



EMEA Product Information Centre

Free phone: 00 800 27 27 5374

(from AT, BE, CH, CZ, DE, DK, EE, ES, FI, FR, IE, IL, IS, IT, LU, MT, NL, NO, PL, PT, RU, SE, SK, UK, ZA)

US Product Information Centre

Toll-free number: 1-800-27 27 537

www.parker.com/gsf