



Stainless Steel FRLs

Air Preparation Units

PF504 Filter – Miniature

Features

- Stainless steel construction handles most corrosive environments
- Fluorocarbon seals standard
- Meets NACE specifications MR-01-75/ISO 15156
- High flow: 1/4" - 10.85 dm³/s[§]
- 1/8" female threaded drain

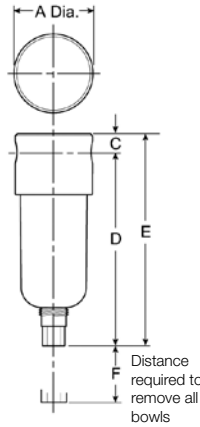
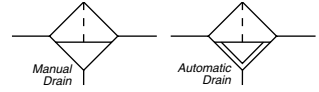

Port Size	BSPB	NPT
	Manual Twist Drain	Manual Twist Drain
1/4"	PF504G02DHSS	PF504-02DHSS

PF504 Filter Dimensions (mm)		
A	C	D
40	8	94
E	F	
102	40	

Standard part numbers shown bold.
 For other models refer to ordering information below.

[§] dm³/s = Flow at 6.2 bar and a 0.3 bar pressure drop.

Ordering Information

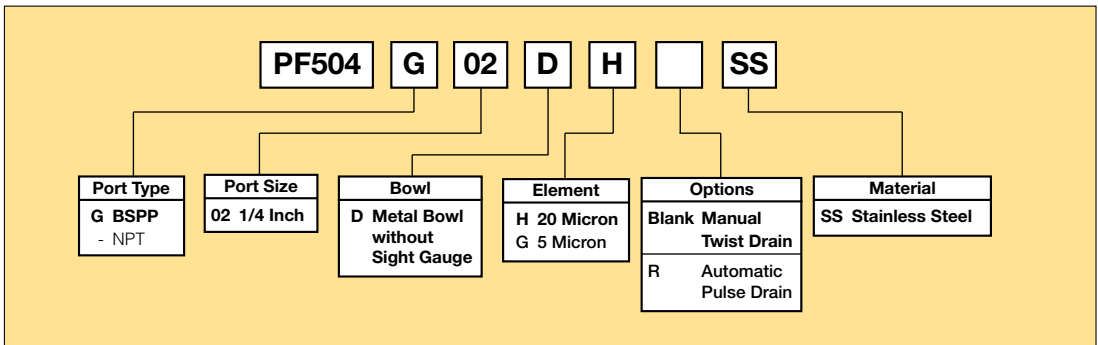

BOLD ITEMS ARE MOST POPULAR.

PF501 Coalescing Filter – Miniature



Features

- Stainless steel construction handles most corrosive environments
- Meets NACE specifications MR-01-75/ISO 15156
- High flow: 1/4" - 755 dm³/s[§]
- 1/8" female threaded drain

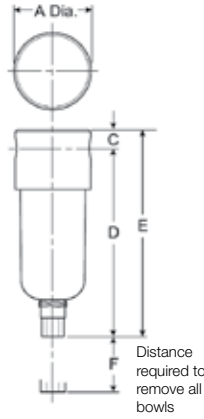

Port Size	BSPP	NPT
	Manual Twist Drain	Manual Twist Drain
1/4"	PF501G02DHSS	PF501-02DHSS

PF501 Coalescing Filter Dimensions (mm)		
A 40	C 8	D 94
E 102	F 40	

Standard part numbers shown bold.
 For other models refer to ordering information below.
[§] dm³/s = Flow at 6.2 bar and a 0.3 bar pressure drop.

Ordering Information

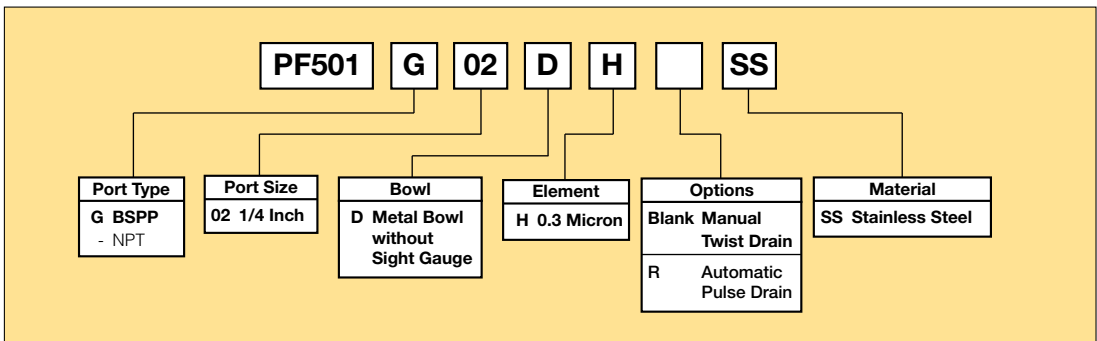

BOLD ITEMS ARE MOST POPULAR.

Technical Specifications – PF501

Operation

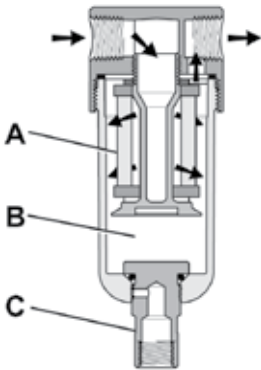

The contaminated air enters the element interior and is forced through a thick membrane (A) of “borosilicate” glass fibers coated with epoxy. Flow then passes through the element, and at this stage 99.97% of the sub micronic particles have been removed from the air stream. The tiny droplets coalesce together and are collected from the filter element by the outer drain layer. The clean, filtered air now passes through and out into the pneumatic system. The air line coalescing filter removes liquid aerosols and sub-micron particulate matter. Collected liquids and particles in the “quiet zone” (B) should be drained before their level reaches a height where they would be reentrained in the flowing air. This can be accomplished by unscrewing the drain valve (C) slightly until the liquid begins to drain.

Technical Information

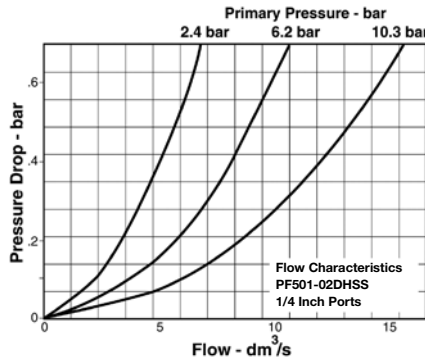

F501 Filter Kits & Accessories

- Filter Element Kits –**
- 0.3 MicronEKF501H
- Drain Kits -**
- Automatic Pulse Drain.....RK504SY-SS
- Manual Twist Drain –**
- Small (Old)SA600Y7-1SS
- Large (New)SAP05481
- Pipe Nipple –**
- 1/4" NPT 316 Stainless Steel..... 616Y28-SS
- 1/4" BSPT 316 Stainless Steel.....AC-2SS

Specifications

- Bowl Capacity** 29 cm³
- Filter Rating** 0.3 Micron
- Port Threads** 1/4 Inch

Pressure & Temperature Ratings –

- Manual Twist Drain 0 to 20.7 bar
 -18°C to 82°C
- Auto Pulse Drain..... 0 to 12 bar
 0°C to 66°C

Note: Air must be dry enough to avoid ice formation at temperatures below 2°C.

- Sump Capacity** 12 cm³
- Weight** 275 g

Materials of Construction

- Body** 316 Stainless Steel
- Bowls** 316 Stainless Steel
- Drain** 316 Stainless Steel
- Element Holder** Acetal
- Filter Element** Borosilicate Fiber
- Seals** Fluorocarbon

PR354, PR364 Regulator – Miniature

Features

- Stainless steel construction handles most corrosive environments
- Large diaphragm to valve area ratio for precise regulation and high flow capacity
- Meets NACE specifications MR-01-75/ISO 15156
- High flow: 1/4" – 5.75 dm³/s[§]

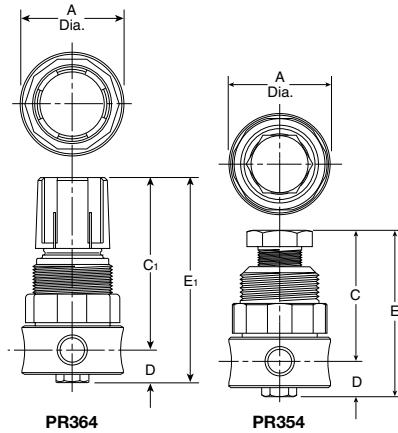

PR364



PR354

Series	Adjustment Type	Port Size	BSPP	NPT
PR364	Knob	1/4"	PR364G02CSS	PR364-02CSS
PR354	All Metal	1/4"	PR354G02CSS	PR354-02CSS

PR354, PR364 Regulator Dimensions (mm)		
A	C	C ₁
40	51	65
D	E	E ₁
13	64	78

Standard part numbers shown bold.

For other models refer to ordering information below.

[§] dm³/s = 7 bar inlet pressure with 5.5 bar set pressure and 1 bar pressure drop.

(mm)
NOTE: 32mm dia. hole required for panel mounting.

⚠ WARNING

**Product rupture can cause serious injury.
Do not connect regulator to bottled gas.
Do not exceed maximum primary pressure rating.**

Ordering Information

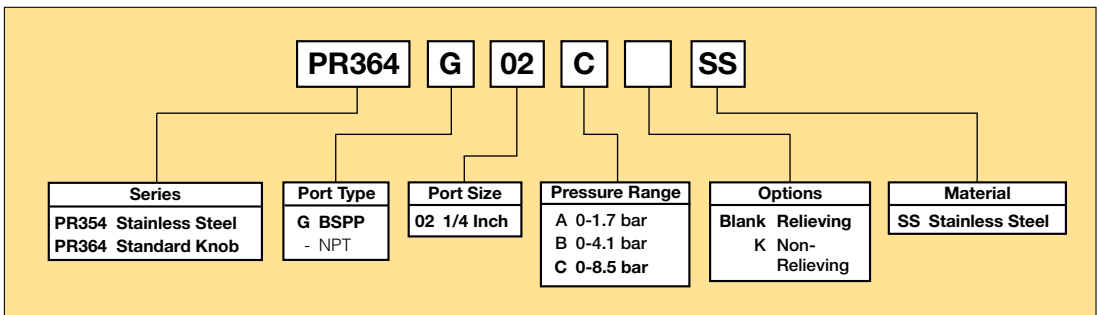

BOLD ITEMS ARE MOST POPULAR.

Technical Specifications – PR354, PR364

Operation

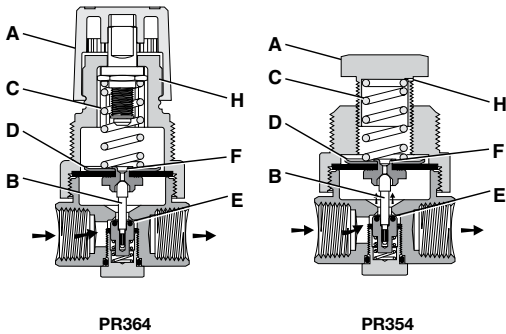

With the adjusting knob (A) turned fully counter-clockwise (no spring load), and pressure supplied to the regulator inlet port, the valve poppet assembly (B) is closed. Turning the adjusting knob clockwise applies a load to control spring (C). This load causes the diaphragm (D) and the valve poppet assembly (B) to move downward allowing flow across the seat area (E) created between the poppet assembly and the seat. Pressure in the downstream line is sensed below the diaphragm (D) and offsets the load of spring (C). As downstream pressure rises, poppet assembly (B) and diaphragm (D) move upward until the area (E) is closed and the load of the spring (C) and pressure under diaphragm (D) are in balance. A reduced outlet pressure has now been obtained, depending on spring load. Creating a demand downstream, such as opening a valve, results in a reduced pressure under the diaphragm (D). The load of control spring (C) now causes the poppet assembly to move downward opening seat area (E) allowing air to flow to meet the downstream demand. The flow of downstream air is metered by the amount of opening (E). Should downstream pressure exceed the desired regulated pressure, the excess pressure will cause the diaphragm (D) to move upward against control spring (C), open vent hole (F), and vent the excess pressure to atmosphere through the hole in the bonnet (H). (This occurs in the relieving type regulator only.)

Technical Information

CAUTION:

REGULATOR PRESSURE ADJUSTMENT –

The working range of knob adjustment is designed to permit outlet pressures within their full range. Pressure adjustment beyond this range is also possible because the knob is not a limiting device. This is a common characteristic of most industrial regulators, and limiting devices may be obtained only by special design.

For best performance, regulated pressure should always be set by increasing the pressure up to the desired setting.

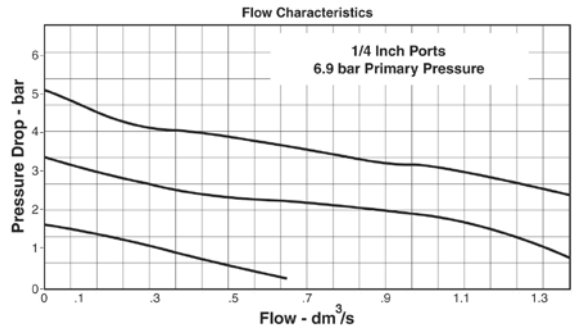

R354, R364 Regulator Kits & Accessories

R354 Bonnet Kit	CKR354YSS
R364 Bonnet Kit (Knob Included)	CKR364YSS
Gauge –	
0 to 10 bar	M1/4G40S-10
Panel Mount Bracket (Stainless)	161X57-SS
Panel Mount Nut –	
Stainless	R05X51SS
Plastic	R05X51-P
Pipe Nipple –	
1/4" NPT 316 Stainless Steel.....	616Y28-SS
1/4" BSPT 316 Stainless Steel.....	AC-2SS
Service Kit –	
Relieving	RKR364YSS
Non-Relieving	RKR364KYSS

Specifications

Gauge Port	1/4 Inch
Operation	Fluorocarbon Diaphragm
Port Threads	1/4 Inch
Pressure & Temperature Ratings –	
PR354.....	20.7 bar -18°C to 82°C
PR364.....	20.7 bar -18°C to 66°C
Note: Air must be dry enough to avoid ice formation at temperatures below 2°C.	
Weight	230 g

Materials of Construction

Adjustment Mechanism / Springs	316 Stainless Steel
Adjusting Knob (PR354)	316 Stainless Steel
Adjusting Knob (PR364)	Polypropylene
Body	316 Stainless Steel
Bonnet (PR354)	316 Stainless Steel
Bonnet (PR364)	Acetal
Bottom Plug	316 Stainless Steel
Poppet	316 Stainless Steel
Seals	Fluorocarbon

PB548, PB558 Filter / Regulator – Miniature

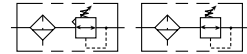

Features

- Stainless steel construction handles most corrosive environments
- Large diaphragm to valve area ratio for precise regulation and high flow capacity
- Meets NACE specifications MR-01-75/ISO 15156.
- High flow: 1/4" – 5.75 dm³/s[§]
- 1/8" female threaded drain

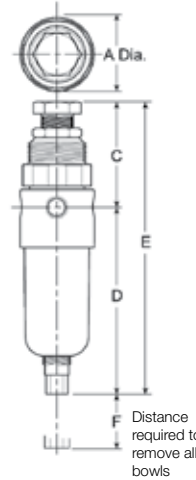
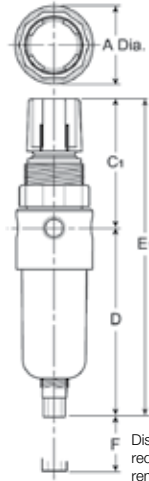

PB548



PB558

Port Size	BSPB	NPT
1/4"	PB548G02DHCSS	PB548-02DHCSS
1/4"	PB558G02DHCSS	PB558-02DHCSS

PB548, PB558 Piggyback Dimensions (mm)		
A	C	C ₁
40	55	67
D	E	E ₁
92	78	147
F		
40		

Standard part numbers shown bold.

For other models refer to ordering information below.

[§] dm³/s = 7 bar inlet pressure with 5.5 bar set pressure and 1 bar pressure drop.

⚠ WARNING
<p>Product rupture can cause serious injury. Do not connect regulator to bottled gas. Do not exceed maximum primary pressure rating.</p>

(mm)
NOTE: 32mm dia. hole required for panel mounting.

Ordering Information

PB548 G 02 D H C SS						
Series	Port Type	Bowl	Element	Reduced Pressure Range	Options	Material
PB548 Standard Knob PB558 Stainless Steel	G BSPP - NPT	D Metal Bowl without Sight Gauge	H 20 Micron G 5 Micron	A 0-1.7 bar B 0-4.1 bar C 0-8.5 bar	Blank Relieving K Non-Relieving R Automatic Pulse Drain	SS Stainless Steel
Port Size						
02 1/4 Inch						

BOLD ITEMS ARE MOST POPULAR.

Technical Specifications – PB548, PB558

Operation

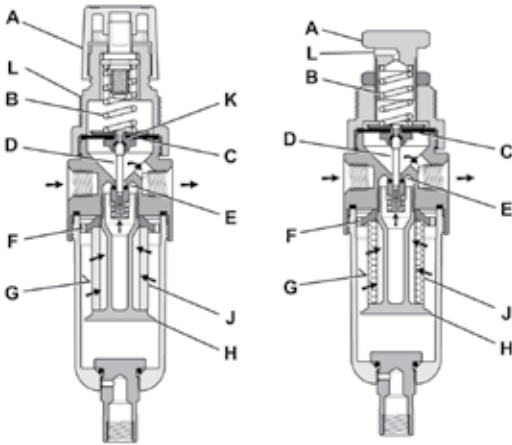

Turning the adjusting knob clockwise applies a load to control spring (B) which forces diaphragm (C) and valve poppet assembly (D) to move downward allowing filtered air to flow through the seat area (E) created between the poppet assembly and the seat. "First stage filtration". Air pressure supplied to the inlet port is directed through deflector plate (F) causing a swirling centrifugal action forcing liquids and coarse particles to the inner bowl wall (G) and down below the lower baffle (H) to the quiet zone. After liquids and large particles are removed in the first stage of filtration "second stage filtration" occurs as air flows through element (J) where smaller particles are filtered out and retained. The air flow now passes through seat area (E) to the outlet port of the unit. Pressure in the downstream line is sensed below the diaphragm (C) and offsets the load of spring (B). When downstream pressure reaches the set-point, poppet valve assembly (D) and diaphragm (C) move upward closing seat area (E). Should downstream pressure exceed the desired regulated pressure, the excess pressure will cause the diaphragm (C) to move upward opening vent hole (K) venting the excess pressure to atmosphere through the hole in the bonnet (L). (This occurs in the standard relieving type filter/regulators only.)

Technical Information

CAUTION:

REGULATOR PRESSURE ADJUSTMENT – The working range of knob adjustment is designed to permit outlet pressures within their full range. Pressure adjustment beyond this range is also possible because the knob is not a limiting device. This is a common characteristic of most industrial regulators, and limiting devices may be obtained only by special design.

For best performance, regulated pressure should always be set by increasing the pressure up to the desired setting.

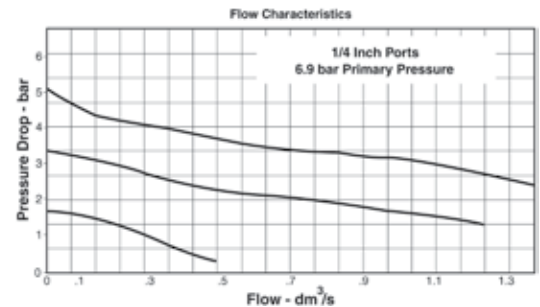

PB548, B558 Regulator Kits & Accessories

Filter Element Kits –	
Particulate (5 Micron)	EK504VY
Particulate (20 Micron)	EK504Y
Gauge –	
0 - 10 bar	M1/4G40S-10
Drain Kits -	
Automatic Pulse Drain	RK504SY-SS
Manual Twist Drain -	
Small (Old)	SA600Y7-1SS
Large (New)	SAP05481
Panel Mount Bracket (Stainless)	161X57-SS
Panel Mount Nut –	
Stainless	R05X51SS
Plastic	R05X51-P
Pipe Nipple –	
1/4" NPT 316 Stainless Steel	616Y28-SS
1/4" BSPT 316 Stainless Steel	AC-2SS
Service Kit –	
Relieving	RK549YSS
Non-Relieving	RK548YSS

Specifications

Bowl Capacity	29 cm ³
Filter Rating	20 Micron
Gauge Port	1/4 Inch
Operation	Fluorocarbon Diaphragm
Port Threads	1/4 Inch
Pressure & Temperature Ratings –	
PB548	20.7 bar max. -18°C to 82°C
PB558	20.7 bar max. -18°C to 82°C
Auto Pulse Drain	0 to 12 bar max. 0°C to 66°C

Note: Air must be dry enough to avoid ice formation at temperatures below 2°C.

Sump Capacity	12 cm ³
Weight	270 g

Materials of Construction

Adjustment Mechanism / Springs	316 Stainless Steel
Body	316 Stainless Steel
Bonnet (PB548)	Acetal
Bonnet (PB558)	316 Stainless Steel
Bottom Plug	316 Stainless Steel
Knob (PB548)	Polypropylene
Knob (PB558)	316 Stainless Steel
Poppet	316 Stainless Steel
Seals	Fluorocarbon

PF10 Filter – Standard

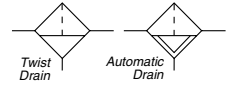

Features

- Stainless steel construction handles most corrosive environments
- Meets NACE specifications MR-01-75/ISO 15156
- High flow: 1/2" - 34 dm³/s[§]
- 1/8" female threaded drain

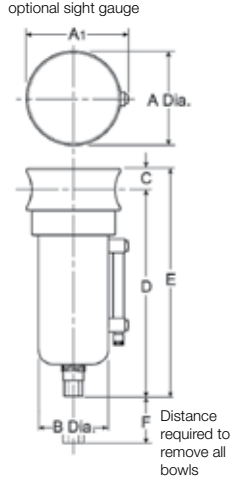

Port Size	BSPP		NPT	
	Manual Twist Drain	Automatic Float Drain	Manual Twist Drain	Automatic Float Drain
1/2"	Metal Bowl Without Sight Gauge			
	PF10G04DJSS	PF10G04DJRSS	PF10-04DJSS	PF10-04DJRSS

PF10 Filter Dimensions (mm)		
A	A1	B
60	64	44
C	D	E
14	127	141
F		
54		

Standard part numbers shown bold.
For other models refer to ordering information below.

[§] dm³/s = Flow at 6.2 bar and a 0.3 bar pressure drop.

(mm)

Ordering Information

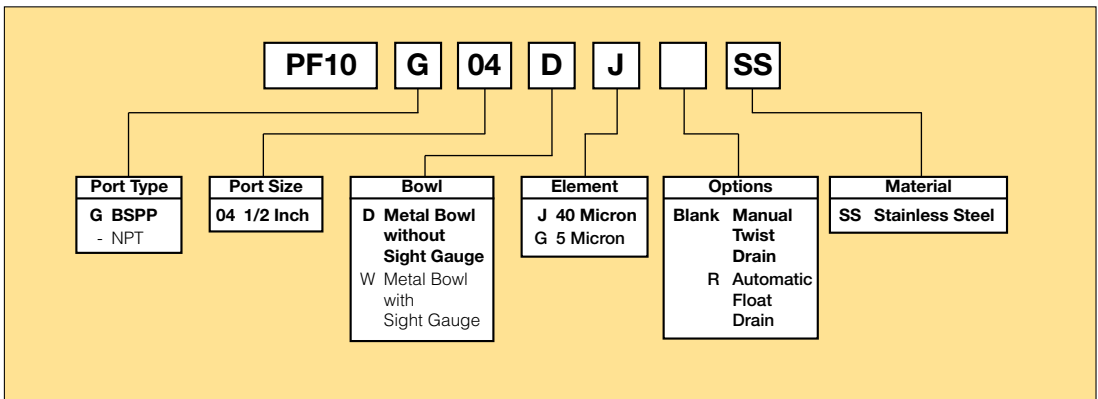

BOLD ITEMS ARE MOST POPULAR.

Technical Specifications – PF10

Operation

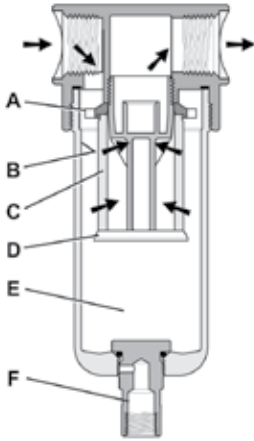

First Stage Filtration:

Air enters at inlet port and flows through deflector plate (A) which causes a swirling action. Liquids and coarse particles are forced to the bowl interior wall (B) by the centrifugal action of the swirling air. They are then carried down the bowl wall by the force of gravity. The baffle (D) separates the lower portion of the bowl into a “quiet zone” (E) where the removed liquid and particles collect, unaffected by the swirling air, and are therefore not reentrained into the flowing air.

Second Stage Filtration:

After liquids and large particles are removed in the first stages of filtration, the air flows through element (C) where smaller particles are filtered out. The filtered air then passes downstream. Collected liquids and particles in the “quiet zone” (E) should be drained before their level reaches a height where they would be reentrained in the flowing air. This can be accomplished by unscrewing the drain valve (F) slightly until the liquid begins to drain.

Technical Information

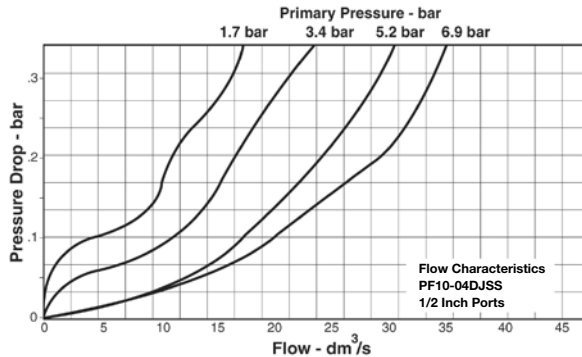

PF10 Filter Kits & Accessories

Drain Kit –

- Automatic Float DrainSA10MDSS
- Manual Twist Drain–
- Small (Old)SA600Y7-1SS
- Large (New)SAP05481

Filter Element Kits –

- Particulate (40 Micron).....EK55J
- Particulate (5 Micron).....EK55G

- Pipe Nipple – 1/2" NPT 316 Stainless Steel** 616Y28-SS
- 1/2" BSPT 316 Stainless SteelAC-4SS

Pressure & Temperature Ratings –

- Manual Twist Drain (D) 0 to 20.7 bar
 -18°C to 82°C
- Manual Twist Drain (W) 0 to 17.2 bar
 -18°C to 66°C
- Automatic Float Drain 0 to 12 bar
 0°C to 66°C

Note: Air must be dry enough to avoid ice formation at temperatures below 2°C.

Weight 850 g

Specifications

- Bowl Capacity** 118 cm³
- Filter Rating** 40 Micron
- Sump Capacity** 50 cm³
- Port Threads** 1/2 Inch

Materials of Construction

- Body** 316 Stainless Steel
- Bowls** 316 Stainless Steel
- Deflector** Acetal
- Drain** 316 Stainless Steel
- Element Holder** Acetal
- Filter Element** Polyethylene
- Seals** Fluorocarbon
- Sight Gauge** Isoplast

PF11 Coalescing Filter – Standard



Features

- Stainless steel construction handles most corrosive environments
- Meets NACE specifications MR-01-75/ISO 15156
- High flow: 1/2" - 21 dm³/s[§]
- 1/8" female threaded drain
- High efficiency 0.01µm filtration
- Removes liquid aerosols and sub micron particles

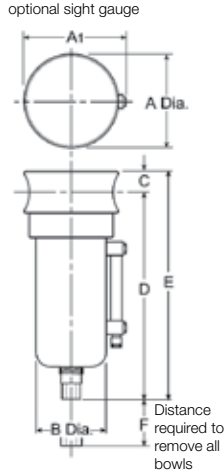

Port Size	BSPP		NPT	
	Manual Twist Drain	Automatic Float Drain	Manual Twist Drain	Automatic Float Drain
1/2"	Metal Bowl Without Sight Gauge			
	PF11G04DJSS	PF11G04DJRSS	PF11-04DJSS	PF11-04DJRSS

F11 Coalescing Filter Dimensions (mm)		
A 60	A1 64	B 44
C 14	D 127	E 141
F 54		

Standard part numbers shown bold.
For other models refer to ordering information below.

[§] dm³/s = Flow at 6.2 bar and a 0.3 bar pressure drop.

(mm)

Ordering Information

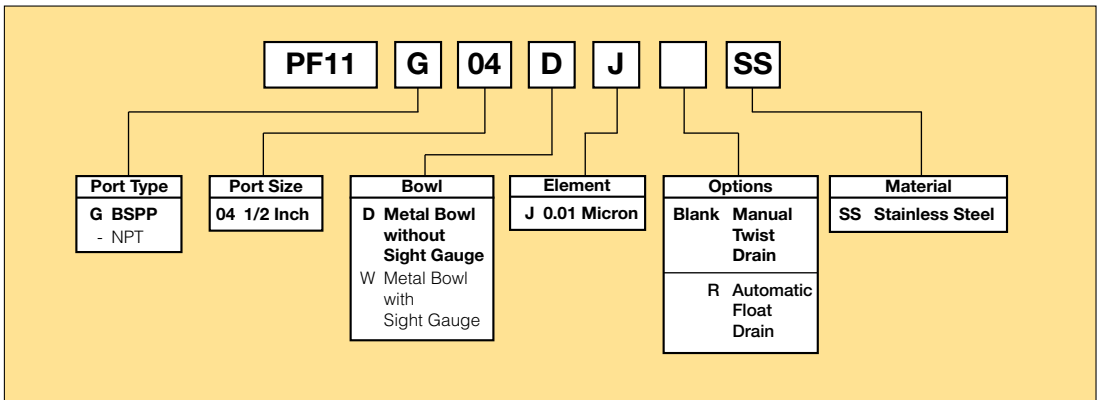

BOLD ITEMS ARE MOST POPULAR.

PR10, PR11 Regulator – Standard

Features

- Stainless steel construction handles most corrosive environments
- Large diaphragm to valve area ratio for precise regulation and high flow capacity
- Meets NACE specifications MR-01-75/ISO 15156
- Low temperature version available
- High flow: 1/2" – 37.75 dm³/s[§]

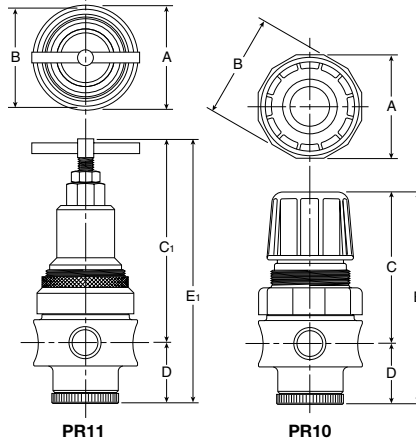

Port Size	BSPP	NPT
1/2"	PR10G04CSS	PR10-04CSS
1/2"	PR11G04CSS	PR11-04CSS

PR10, PR11 Regulator Dimensions (mm)		
A	B	C
60	62	91
C ₁	D	E
119	35	126
E ₁		
154		

Standard part numbers shown bold.

For other models refer to ordering information below.

[§] dm³/s = 7 bar inlet pressure with 5.5 bar set pressure and 1 bar pressure drop.

⚠ WARNING
<p>Product rupture can cause serious injury. Do not connect regulator to bottled gas. Do not exceed maximum primary pressure rating.</p>

(mm)
NOTE: 44mm dia. hole required for panel mounting.

Ordering Information

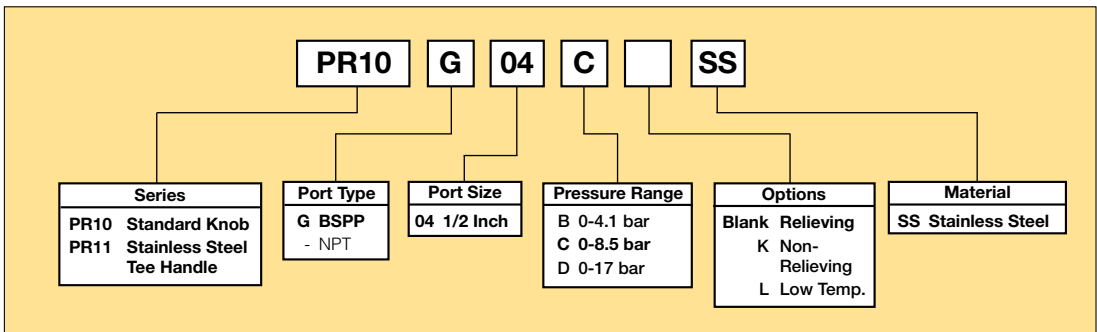

BOLD ITEMS ARE MOST POPULAR.

Technical Specifications – PR10, PR11

Operation

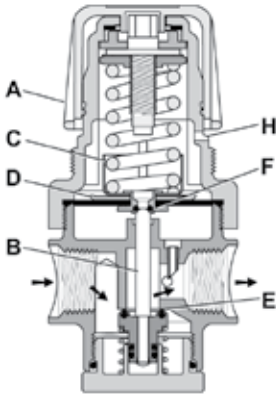

With the adjusting knob (A) turned fully counter-clockwise (no spring load), and pressure supplied to the regulator inlet port, the valve poppet assembly (B) is closed. Turning the adjusting knob clockwise applies a load to control spring (C). This load causes the diaphragm (D) and the valve poppet assembly (B) to move downward allowing flow across the seat area (E) created between the poppet assembly and the seat. Pressure in the downstream line is sensed below the diaphragm (D) and offsets the load of spring (C). As downstream pressure rises, poppet assembly (B) and diaphragm (D) move upward until the area (E) is closed and the load of the spring (C) and pressure under diaphragm (D) are in balance. A reduced outlet pressure has now been obtained, depending on spring load. Creating a demand downstream, such as opening a valve, results in a reduced pressure under the diaphragm (D). The load of control spring (C) now causes the poppet assembly to move downward opening seat area (E) allowing air to flow to meet the downstream demand. The flow of downstream air is metered by the amount of opening (E).

Should downstream pressure exceed the desired regulated pressure, the excess pressure will cause the diaphragm (D) to move upward against control spring (C), open vent hole (F), and vent the excess pressure to atmosphere through the hole in the bonnet (H). (This occurs in the relieving type regulator only)

Technical Information

CAUTION:

REGULATOR PRESSURE ADJUSTMENT –

The working range of knob adjustment is designed to permit outlet pressures within their full range. Pressure adjustment beyond this range is also possible because the knob is not a limiting device. This is a common characteristic of most industrial regulators, and limiting devices may be obtained only by special design.

For best performance, regulated pressure should always be set by increasing the pressure up to the desired setting.

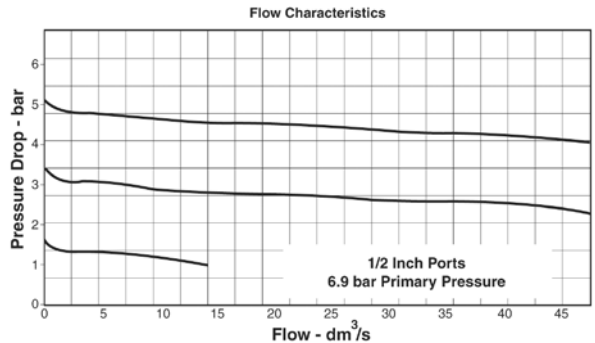

PR10, PR11 Regulator Kits & Accessories

R10 Bonnet Kit (Knob Included)	CKR10YSS
R11 Bonnet Kit	CKR11YSS
Gauge –	
0 - 10 bar	M1/4G40S-10
Panel Mount Bracket (Stainless)	R10Y57-SS
Panel Mount Nut –	
Stainless	R10X51SS
Plastic	R10X51-P
Pipe Nipple –	
1/2" NPT 316 Stainless Steel	616Y28-SS
1/2" BSPT 316 Stainless Steel	AC-4SS
Service Kit –	
Relieving	RKR10YSS
Non-Relieving	RKR10KYSS

Materials of Construction

Adjustment Mechanism / Springs	316 Stainless Steel
Body	316 Stainless Steel
Bonnet / Tee Handle (PR11)	316 Stainless Steel
Bonnet / Knob (PR10)	Acetal
Bottom Plug	316 Stainless Steel
Poppet	316 Stainless Steel
Seals	Fluorocarbon

Specifications

Gauge Port	1/4 Inch
Operation	Fluorocarbon Diaphragm
Port Threads	1/2 Inch
Pressure & Temperature Ratings –	
PR10	20.7 bar max. -18°C to 66°C
PR11	20.7 bar max. -18°C to 82°C
Option "L" minimum operating temperature*	-40° C/F

Note: Air must be dry enough to avoid ice formation at temperatures below 2°C.

Weight

* Note: "Low Temperature" option is intended for applications where the ambient temperature may be down to -40° C/F. Air supply must be free of moisture to prevent ice formation and malfunction of units. These units contain EPDM seals. Make sure any oils in the airstream are compatible.



PB11, PB12 Filter / Regulator – Standard

Features

- Stainless steel construction handles most corrosive environments
- Large diaphragm to valve area ratio for precise regulation and high flow capacity
- Meets NACE specifications MR-01-75/ISO-15156
- Low temperature version available
- High flow: 1/2" – 34 dm³/s[§]
- 1/8" female threaded drain

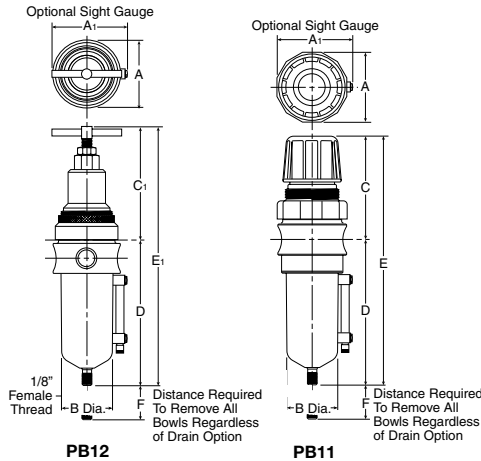
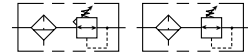

Port Size	Adjustment Type	BSPP		NPT	
		Manual Twist Drain	Automatic Float Drain	Manual Twist Drain	Automatic Float Drain
1/2"	Metal Bowl without Sight Gauge				
	Knob	PB11G04DJCSS	PB11G04DJCRSS	PB11-04DJCSS	PB11-04DJCRSS
	Tee-Handle	PB12G04DJCSS	PB12G04DJCRSS	PB12-04DJCSS	PB12-04DJCRSS

PB11, PB12 Piggyback Dimensions (mm)		
A	A ₁	B
60	64	44
C	C ₁	D
91	55	127
E	E ₁	F
218	246	54

Standard part numbers shown bold. For other models refer to ordering information below.

[§] dm³/s = 7 bar inlet pressure with 5.5 bar set pressure and 1 bar pressure drop.

(mm)
NOTE: 44mm dia. hole required for panel mounting.

⚠ WARNING

**Product rupture can cause serious injury.
Do not connect regulator to bottled gas.
Do not exceed maximum primary pressure rating.**

Ordering Information

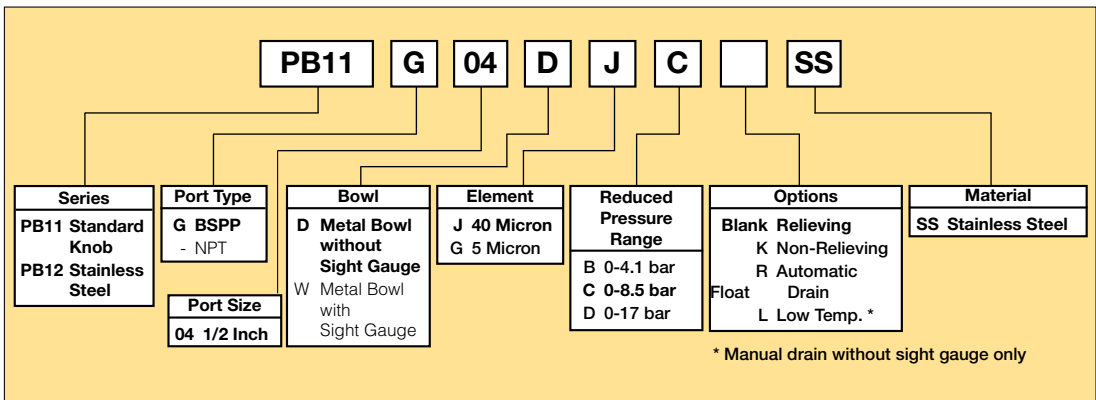

BOLD ITEMS ARE MOST POPULAR.

Technical Specifications – PB11, PB12

Operation

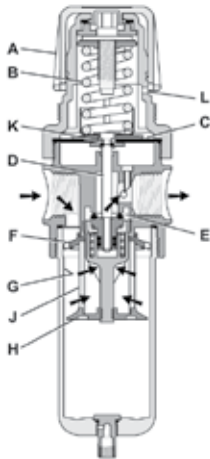

Turning the adjusting knob clockwise applies a load to control spring (B) which forces diaphragm (C) and valve poppet assembly (D) to move downward allowing filtered air to flow through the seat area (E) created between the poppet assembly and the seat. "First stage filtration". Air pressure supplied to the inlet port is directed through deflector plate (F) causing a swirling centrifugal action forcing liquids and coarse particles to the inner bowl wall (G) and down below the lower baffle (H) to the quiet zone. After liquids and large particles are removed in the first stage of filtration "second stage filtration" occurs as air flows through element (J) where smaller particles are filtered out and retained. The air flow now passes through seat area (E) to the outlet port of the unit. Pressure in the downstream line is sensed below the diaphragm (C) and offsets the load of spring (B). When downstream pressure reaches the set-point, poppet valve assembly (D) and diaphragm (C) move upward closing seat area (E). Should downstream pressure exceed the desired regulated pressure, the excess pressure will cause the diaphragm (C) to move upward opening vent hole (K) venting the excess pressure to atmosphere through the hole in the bonnet (L). (This occurs in the standard relieving type filter/regulators only.)

Technical Information

CAUTION:

REGULATOR PRESSURE ADJUSTMENT – The working range of knob adjustment is designed to permit outlet pressures within their full range. Pressure adjustment beyond this range is also possible because the knob is not a limiting device. This is a common characteristic of most industrial regulators, and limiting devices may be obtained only by special design.

For best performance, regulated pressure should always be set by increasing the pressure up to the desired setting.

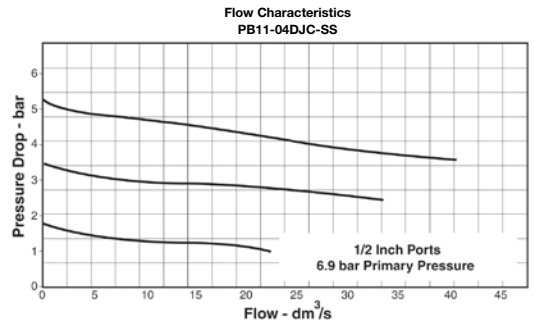

PB11, PB12 Regulator Kits & Accessories

Drain Kits -	
Automatic Float Drain.....	SA10MDSS
Manual Twist Drain -	
Small (Old).....	SA600Y7-1SS
Large (New).....	SAP05481
Filter Element Kits –	
Particulate (40 Micron).....	EKF10Y
Particulate (5 Micron).....	EKF10VY
Gauge –	
0 - 10 bar.....	M1/4G40S-10
Panel Mount Bracket (Stainless)	R10Y57-SS
Panel Mount Nut –	
Stainless.....	R10X51SS
Plastic.....	R10X51-P
Pipe Nipple –	
1/2" NPT 316 Stainless Steel.....	616Y28-SS
1/2" BSPT 316 Stainless Steel.....	AC-4SS
Service Kit –	
Relieving.....	RKR10YSS
Non-Relieving.....	RKR10KYSS

Materials of Construction

Adjustment Mechanism / Springs	316 Stainless Steel
Body	316 Stainless Steel
Bonnet / Knob (PB11)	Acetal
Bonnet / Tee Handle (PB12)	316 Stainless Steel
Bottom Plug	316 Stainless Steel
Poppet	316 Stainless Steel
Seals	Fluorocarbon
Sight Gauge	Isoplast

Specifications

Bowl Capacity	118 cm ³
Filter Rating	40 Micron
Gauge Port	1/4 Inch
Operation	Fluorocarbon Diaphragm
Port Threads	1/2 Inch
Pressure & Temperature Ratings –	
PB11 (Metal bowl D or W).....	20.7 bar -18°C to 66°C
PB12 (Metal bowl D).....	20.7 bar -18°C to 82°C
PB12 (Metal bowl W).....	20.7 bar -18°C to 66°C
Automatic float drain.....	1 to 12 bar 0°C to 66°C
Option "L" minimum operating temperature*	-40° C/F
Note: Air must be dry enough to avoid ice formation at temperatures below 2°C.	
Sump Capacity	50 cm ³
Weight	1090 g

* Note: "Low Temperature" option is intended for applications where the ambient temperature may be down to -40° C/F. Air supply must be free of moisture to prevent ice formation and malfunction of units. These units contain EPDM seals. Make sure any oils in the airstream are compatible.



PL10 Lubricator – Standard

Features

- Stainless steel construction handles most corrosive environments
- Fillable under pressure
- Meets NACE specifications MR-01-75/ISO 15156
- High flow: 1/2" - 47 dm³/s[§]
- 1/8" female threaded drain

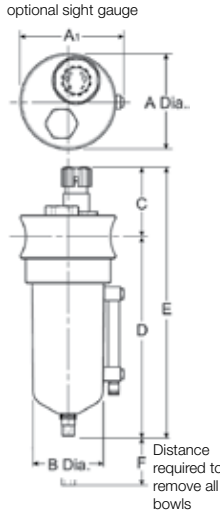

Port Size	BSPP	NPT
	Manual Twist Drain	Manual Twist Drain
1/2"	Metal Bowl Without Sight Gauge	
	PL10G04DSS	PL10-04DSS

PL10 Lubricator Dimensions (mm)		
A	A1	B
60	64	44
C	D	E
46	127	173
F		
89		

Standard part numbers shown bold.
For other models refer to ordering information below.

[§] dm³/s = Flow at 6.2 bar and a 0.3 bar pressure drop.

Ordering Information

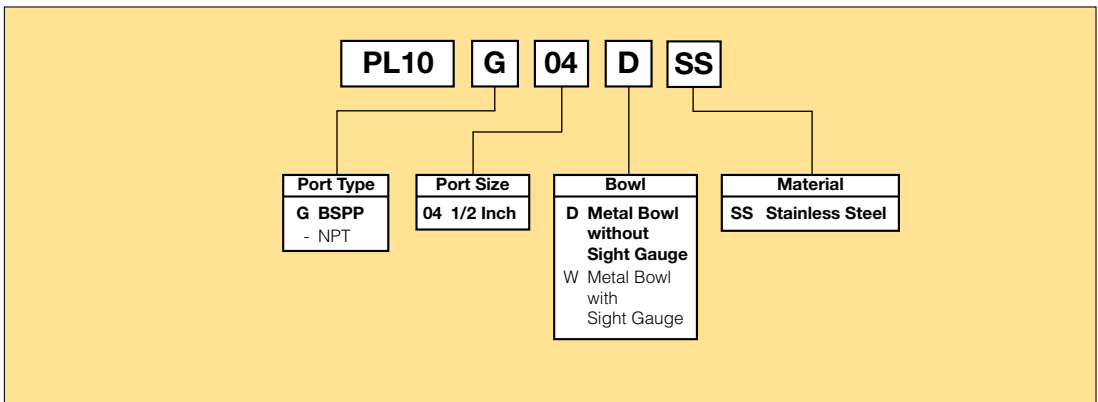

BOLD ITEMS ARE MOST POPULAR.

Technical Specifications – PL10

Operation

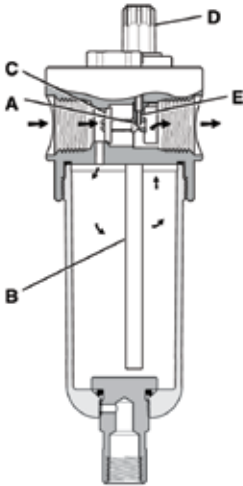

Air flowing through the unit goes through two paths. At low flow rates the majority of the air flows through the Venturi section (A). The rest of the air opens the check valve (C). The velocity of the air flowing through the Venturi section (A) creates a pressure drop. This lower pressure allows the oil to be forced from the reservoir by the pickup tube (B) and travels up to the metering screw (D). The rate of oil delivery is then controlled by adjusting the metering screw (D). Oil flows past the metering screw (D) and forms a drop in the nozzle tube (E). As the oil drops through the dome (F) and back into the Venturi section (A), it is broken up into fine particles. It is then mixed with the air flowing past the check valve (C) and is carried downstream. As the air flow increases the check valve (C) will open more fully. This additional flow will assure that the oil delivery rate will increase linearly with the increase of air flow.

Technical Information

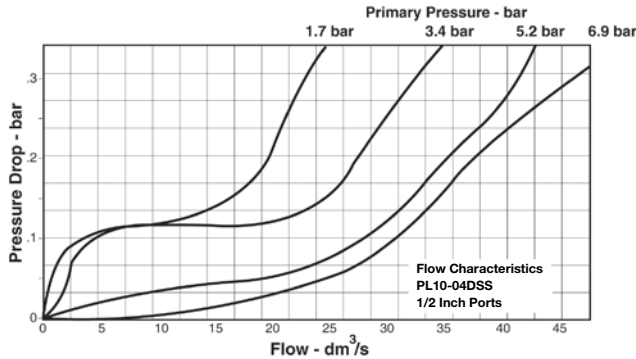

L10 Filter Kits & Accessories

- Drain Kits -**
- Manual Twist Drain -**
- Small (Old).....SA600Y7-1SS
- Large (New).....SAP05481
- Pipe Nipple –**
- 1/2" NPT 316 Stainless Steel..... 616Y28-SS
- 1/2" BSPT 316 Stainless Steel.....AC-4SS
- Sight Dome Kit** RKL10SS

Specifications

- Bowl Capacity** 118 cm³
- Port Threads** 1/2 Inch
- Pressure & Temperature Ratings –**
- Metal Bowl (D)20.7 bar max.
 -18°C to 66°C
- Metal Bowl (W) 0 to 17.2 bar
 -18°C to 66°C

Note: Air must be dry enough to avoid ice formation at temperatures below 2°C.

Weight 850 g

Materials of Construction

- Body**316 Stainless Steel
- Bowl**316 Stainless Steel
- Dip Tube**316 Stainless Steel
- Drain**316 Stainless Steel
- Fill Plug**316 Stainless Steel
- Seals**Fluorocarbon
- Sight Dome**Nylon
- Sight Gauge**Isoplast

