

Moduflex Compressed Air Filters

The most energy efficient compressed air filters in the world

Compressed Air - The 4th Utility

Compressed air is a safe and reliable power source that is widely used throughout industry. approximately 90% of all companies use compressed air in some aspect of their operations, however unlike gas, water and electricity, compressed air is generated on-site, giving the user responsibility for air quality and operational costs.

compressed air is not without it's problems, with all systems suffering from performance and reliability issues. almost all of these can be directly attributed to contamination, the main sources of which are :

- the ambient air being drawn into the compressor
- the type and operation of the air compressor
- compressed air storage vessels
- distribution pipework

There are 10 major contaminants found in a compressed air system, these are:

- Water Vapour
- Condensed Water
- Water Aerosols
- Atmospheric Dirt
- Rust
- Pipescale
- Liquid Oil
- Oil Aerosols
- Oil Vapour
- Micro-organisms



The largest quantity of contamination introduced into the compressed air system originates from the atmospheric air drawn into the compressor and not as often believed, introduced by the compressor itself. The most prolific and problematic of the contaminants is water which accounts for 99.9% of the total liquid contamination found in a compressed air system.

High efficiency compressed air filtration is not only used to remove particulate and oil, but more importantly it removes water aerosols and is key to operating an efficient and cost effective compressed air system.

Regardless of what type of compressor is installed, the same level of filtration is required.

Contaminant removal

Failure to remove this contamination can cause numerous problems in the compressed air system, such as:

- Corrosion within storage vessels and the distribution system
- Blocked or frozen valves, cylinders, air motors and tools
- Damaged production equipment
- Premature unplanned desiccant changes for adsorption dryers

In addition to problems associated with the compressed air system itself, allowing contamination such as water, particulate, oil and micro-organisms to exhaust from valves, cylinders, air motors and tools, can lead to an unhealthy working environment with the potential for personal injury, staff absences and financial compensation claims.

Compressed air contamination will ultimately lead to:

- Inefficient production processes
- Spoiled, damaged or reworked products
- Reduced production efficiency
- Increase manufacturing costs

Not all Compressed Air Filters are the same

Compressed air filtration is essential to all modern production facilities. It must deliver promising performance and reliability whilst providing the right balance of air quality with the lowest cost of operation. today,

many manufacturers offer products for the filtration and purification of contaminated compressed air, which are often selected only upon their initial purchase cost, with little or no regard for the air quality they provide

or the cost of operation throughout their life. when purchasing purification equipment, the delivered air quality, cost of operation and the overall cost of ownership must always be considered.

Air quality

Compressed air purification equipment is installed to deliver high quality, clean dry air, and to eliminate the problems and costs associated with contamination. When selecting this type of equipment, the delivered air quality and the verification of performance must always be the primary driver, otherwise why install it in the first place.

- **Moduflex Extras filters provide air quality in accordance with ISO 8573.1:2001, the international standard for compressed air quality**
- **Moduflex Extras adsorption filters are also tested in accordance with the test methods of the ISO 8573 series**
- **Moduflex Extras filter performance has been independently verified by Lloyds Register**
- **Moduflex Extras coalescing filters are covered by a one year compressed air quality guarantee**
- **The air quality guarantee is automatically renewed with annual maintenance**
- **Moduflex Extras coalescing filters are the first range of filters specifically designed to deliver air quality in accordance with ISO 8573.1 : 2001 when tested with the stringent requirements of the new ISO 12500-1 international standard for Compressed Air Filter Testing**

Energy efficiency

After air quality, the next consideration when selecting a compressed air filter is the cost of operation. Moduflex Extras filters not only provide air quality in accordance with the international standards, they are designed to do so with the lowest operational costs available.

- **Moduflex Extras filters use aerospace technology to keep pressure losses to a minimum**
- **Deep pleat element technology and specially treated filtration media provides a low pressure loss filter element with 450% more filtration surface area when compared to a conventional wrapped filter, and 200% greater area than typical pleated filter elements**
- **Overall pressure losses start low and stay low throughout the 12 month life of the filter element**
- **Can help to significantly reduce your carbon footprint**

Alternative Manufacturer Initial saturated differential pressure	Annual Savings with Moduflex Extras	
	Energy Savings Kw	Environmental Saving Kg/CO ₂
200	4,973	2,139
250	6,259	2,691
300	9,619	4,136
350	12,979	5,581
400	16,339	7,026
450	19,699	8,470
500	23,059	9,915

Example based upon :

- System pressure : 7 bar g
- Compressor Size : 120 Kw
- Duration of Operation : 8000 Hrs
- Moduflex Extras Coalescing Filter
0.01 micron (0.01mg/m³)
- Alternative Manufacturer's Coalescing Filter
0.01 micron (0.01mg/m³)

Low lifetime costs

Equipment with a low purchase price may turn out to be a more costly investment in the long term. By guaranteeing air quality and ensuring energy consumption is kept to a minimum, Parker Moduflex Extras filters can reduce the total cost of ownership and help improve your bottom line through improved manufacturing efficiencies.

Air Quality

The Moduflex Extras range of compressed air filters has been designed from the outset to meet the requirements of ISO 8573.1 : 2001,

the International standard for compressed air quality, when validated in accordance with the requirements of ISO 12500, the International standard

for filter testing and the test methods of ISO 8573.2, ISO 8573.4 and ISO 8573.5.

Correct selection of filtration media

Coalescing and dust removal filters use a high efficiency borosilicate glass nanofibre material which has a 96% voids volume, providing media with excellent filtration efficiency and a high dirt holding capacity.

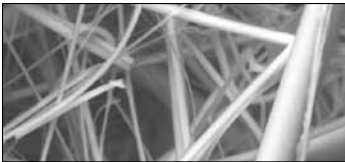

Moduflex Extras coalescing filters utilise four drainage methods to ensure high performance, whilst conventional filters only use one.

Drainage method 1

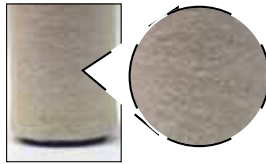

High efficiency drainage layer provides increased liquid drainage, improved chemical compatibility and higher operational temperatures when compared to conventional materials.

Construction of the filtration media into a filter element

Moduflex Extras filter elements use pleated not wrapped filter media, which is constructed using a unique deep bed pleating technique. This provides 450% more filtration surface area when compared to a traditional wrapped filter element and around 200% more surface area compared to a traditional pleated element.

Deep bed pleating also reduces the air flow velocity within the media, which further improves filtration performance.



Drainage method 2

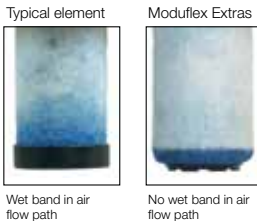

Traditional elements have a build up of liquid known as a "wet band" where the drainage layer is glued into the lower endcap.

The Moduflex Extras design wraps the drainage layer under lower endcap removing coalesced liquid from the air flow path, increasing liquid removal efficiency, and providing more usable filtration surface area.

Drainage method 3

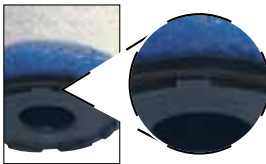

Surface tension breakers are moulded into the lower filter element endcap to prevent liquid from sticking, and to ensure fast and efficient drainage of coalesced liquid.

Drainage method 4

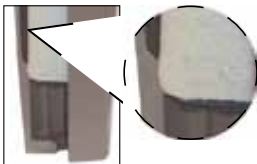

Drainage ribs cast into the filter bowl compress the lower part of the filter element, allowing bulk liquid to rapidly drain from the filter element through capillary action.

Energy Efficiency

Any restriction to airflow within a filter housing / element will reduce the system pressure, to generate compressed air, large amounts of electrical energy is required, therefore any pressure lost within the system can be directly converted into a cost for wasted energy. The higher the pressure loss, the higher the energy costs.

Pressure loss in a compressed air filter is a combination of fixed pressure losses and incremental pressure losses. Fixed pressure losses come from the filter housing and the interface between the filter housing and filter element. Incremental pressure losses come from the filter element as it blocks up with contamination during operation.

In most filters, high operational costs are generally due to a poorly designed airflow path within the filter housing and element and poorly selected filtration media. In addition to this, the high differential pressure change points recommended by many filter manufacturers increase operational costs even further.

Providing an optimal flow path for the compressed air is key to reducing system operating costs.

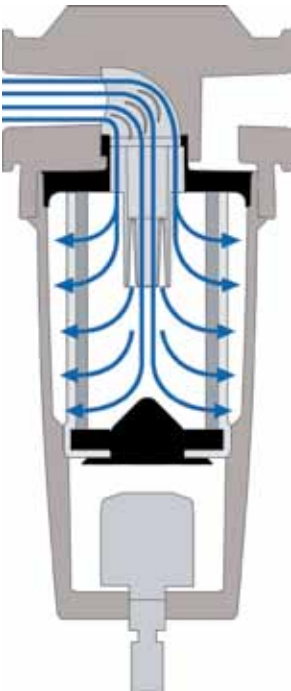

Aerospace Flow Management System

“Bell mouth” housing inlet & full flow inlet conduit



Moduflex Extras filter housings feature a “Bell Mouth” inlet to provide a smooth, turbulent free transition for the air as it enters into the filter element without restriction through the full flow element inlet conduit.

Smooth 90° elbow & aerospace turning vanes



In aerodynamic terms, a design which turns the air sharply through 90° is known as an inefficient corner. This typically has always been the method used to direct air into a compressed air filter element.

Moduflex Extras uses a smooth 90° elbow to direct air into the filter element, reducing turbulence and pressure losses significantly by turning the inefficient, sharp 90° corner into an efficient one.

As the diameter for the conduit increases, the benefits are reduced, therefore filter sizes 3/8” to 3” also include aerospace turning vanes which channels the air through a number of smaller, more efficient corners, reducing pressure loss and energy consumption even further.

Flow distributor



Filter sizes 3/8” to 3” include an upper flow distributor and all models include a lower conical flow diffuser.

The upper flow distributor provides turbulent free distribution of the air flow throughout the filter element ensuring full utilisation of all available filtration media, increasing filtration performance and reducing energy consumption.

Conical flow diffuser



The combination of conical flow diffuser and a drainage layer wrapped under the lower endcap allows airflow through the lowest section of the element, which is not possible on conventional filters due to the position of the “wet band”.

Advanced Filter housing

Moduflex Extras filter housings have been designed to provide simple installation, long housing life and reduced maintenance times.

The unique design of the Moduflex Extras filter provides more port sizes for flexibility and ensures service

technicians do not have to contact contaminated elements during maintenance.



No corrosion with Alocrom treatment.



Rapid corrosion of untreated aluminium.



Float drain

Filter connections

Port sizes are available to match both pipe size and system flow rate giving additional customer choice and reduced installation costs.

Compact and lightweight

Advanced element design provides a smaller, more compact filter.

Fully corrosion protected

All Moduflex Extras filters undergo cleaning, de-greasing and Alocrom treatment before painting. Alocrom treatment not only primes the aluminium surface for painting, it also provides corrosion protection. Additionally, all Moduflex Extras filter housings are also externally protected with a tough, durable dry powder epoxy coating.

Moduflex Extras filter housings are provided with a 10 year housing guarantee.

'Clean change' filter element

Element changes are now easy and do not require the user to touch the contaminated element during annual element change.

Minimal service clearance

Space saving design minimises service clearance and allows installation in confined spaces.

Choice of drains

Coalescing filters are fitted as standard with energy efficient, zero air loss float drains for the removal of coalesced liquids. Adsorption filters are fitted with a manual drain.

Optional accessories

Additional mounting and interconnecting hardware is available.



LRQ4003083



LRQ4001479

INTERNATIONAL APPROVALS



CRN



ASME VIII National Board

AS1210



BRITISH COMPRESSED AIR SOCIETY LIMITED



Maintaining air quality and energy efficiency through regular maintenance

It has long been the practice to change filter elements based upon the pressure drop measured across the filter as this is directly attributable to operational costs.

However, one must remember the reason for installing the filter in the first place, i.e. to remove contamination.

Filter elements must always be replaced in accordance with the manufacturers instructions to ensure the delivered air quality is never compromised.

'Why should I change my filter element?'

To achieve the stringent air quality levels required by both modern industry and ISO 8573.1 : 2001 the international standard for compressed air quality, highly specialised filtration materials are employed, which has both a finite life and a finite capacity to retain contamination.

It is important to remember that when the filter life has expired, the required air quality can no longer be maintained.

Filters are installed to provide contaminant removal to a specific air quality requirement, therefore the primary reason to change filter elements should always be to maintain air quality.

Filter elements should be changed based upon manufacturers recommendations to maintain air quality.

"My filter is fitted with a differential pressure gauge and the needle is in the green - why should I change my element ?"

Many filter housings are fitted with "Differential Pressure Gauges". Generally, these are indicators not precise gauges and offer no level of calibration. Typically these will show an area of green and red, indicating if the needle is in the green, that the element does not require changing.

Differential pressure gauges are not filter service indicators or air quality indicators, they are simply measuring differential pressure and offer an indication of premature blockage.

As the filter media in an element degrades, even a tiny hole can result in the filter media rupturing, allowing all contamination to be carried past the filter into the system. If this should happen, the needle on the gauge would always indicate in the green area and the element would never be serviced until the user spotted contamination downstream. If the element was replaced after such an incident, contamination will still be present downstream of the filter for some time.

What are the consequences of not changing filter elements?

What seems like a cost saving in the short term can turn out to be a very costly mistake. Having identified a contamination problem in the compressed air system and the need for purification equipment, what would be the cost to your business of poor air quality?

- **Damaged adsorption dryer beds requiring unplanned desiccant changes**
- **Corrosion within the compressed air storage and distribution system**
- **Blocked / frozen valves and air motors**
- **Damaged machinery**
- **Contamination exhausting from valves and cylinders leading to unhealthy working environments, risk of personal injury, staff absences and personal injury claims**
- **Inefficient production processes**
- **Spoiled, damaged products**
- **Re-worked products**
- **Increased manufacturing costs**
- **Increased production downtime**



What are the benefits of regularly changing filter elements?

- **High quality compressed air - Guaranteed**
- **Protection of adsorption dryer beds**
- **Protection of downstream equipment, personnel and processes**
- **Reduced operational costs**
- **Increased productivity & profitability**
- **Continued peace of mind**

High Efficiency 0.01 µm Filtration

Filtration Grade

Filtration type	Coalescing
Particle removal (inc water & oil aerosols)	Down to 0.01 micron
Max remaining oil content at 21°C	0.01 mg/m ³ 0.01 ppm(w)
Filter efficiency	99.9999%
Test methods used	ISO 8573.2 ISO 8573.4 ISO 12500-1
ISO 12500-1 Inlet Challenge concentration	10 mg/m ³
Initial dry differential pressure	<140 mbar (2psi)
Initial saturated differential pressure	<200 mbar (3psi)
Change element every	12 months
Precede with filtration grade	1 micron Moduflex Coalescer



Product selection

Stated flows are for operation at 7 bar (g) with reference to 20°C, 1 bar (a), 0% relative water vapour pressure. For flows at other pressures apply the correction factors shown.

Port Size	Part Number	dm ³ /s	m ³ /hr	cfm	0.01 µm Replacement Element Kit
1/4"	P3TFA22CAAN	10	36	21	P3TKA00ESCA
3/8"	P3TFA23CBAN	20	72	42	P3TKA00ESCB
1/2"	P3TFA24CCAN	30	108	64	P3TKA00ESCC
3/4"	P3TFA26CDAN	60	216	127	P3TKA00ESCD
1"	P3TFA28CEAN	110	396	233	P3TKA00ESCE
1.1/4"	P3TFA2ACEAN	110	396	233	P3TKA00ESCE
1.1/2"	P3TFA2BCFAN	160	576	339	P3TKA00ESCF
1.1/2"	P3TFA2BCGAN	220	792	466	P3TKA00ESCG
2"	P3TFA2CCHAN	330	1188	699	P3TKA00ESCH
2.1/2"	P3TFA2DCJAN	430	1548	911	P3TKA00ESCJ
3"	P3TFA2ECJAN	430	1548	911	P3TKA00ESCJ
2.1/2"	P3TFA2DCKAN	620	2232	1314	P3TKA00ESCK
3"	P3TFA2ECKAN	620	2232	1314	P3TKA00ESCK

Correction factors

Line pressure bar g	psi g	Correction factor
1	15	0.38
2	29	0.53
3	44	0.65
4	58	0.76
5	73	0.85
6	87	0.93
7	100	1.00
8	116	1.07
9	131	1.13
10	145	1.19
11	160	1.25
12	174	1.31
13	189	1.36
14	203	1.41
15	218	1.46
16	232	1.51

To find the correction factor for 8.5 bar g (122psi g) =

$$\sqrt{\frac{\text{System Operating Pressure}}{\text{Nominal Pressure}}} = \sqrt{\frac{8.5 \text{ bar g}}{7 \text{ bar g}}} = 1.10$$

Filter selection example

Selecting a filter model to match a system flow rate and pressure.

Example: System flow 1050 m³/hr at a pressure of 8.5 bar g

1. Obtain pressure correction factor from table or calculate factor using method shown. Correction factor for 8.5 bar g = 1.10
2. Divide system flow by correction factor to give equivalent flow rate at 7 bar g
1050m³/hr ÷ 1.10 = 955 m³/hr (at 7 bar g)
3. Select a filter model from the above table with a flow rate above or equal to 955 m³/hr. Filter model selected : P3TFA2CCHAN
4. Select pipe connection & Thread type System uses 2" piping and BSP threads: Model P3TFA2CCHAN

High Efficiency 0.01 µm Filtration

Technical data

Filter Grade	Drain type	Max operating pressure		Max recommended operating temp.		Min recommended operating temp.	
		bar g	psi g	°C	°F	°C	°F
0.01 micron	Auto	16	232	80°C	176°F	1.5°C	35°F

Weights and dimensions

Optional Accessories

Port Size	Part Number	A		B		C		D		E		F		G		Weight		Modular Connection Kit	Wall Mounting Bracket Kit
		mm	ins	mm	ins	mm	ins	mm	ins	mm	ins	mm	ins	mm	ins	kg	lbs		
1/4"	P3TFA22CAAN	76.0	3.0	181.5	7.2	153.0	6.0	18.0	0.71	24.5	0.96	30.0	1.18	52.0	2.05	0.4	0.9	P3TKA00CBA	P3TKA00MWA
3/8"	P3TFA23CBAN	97.5	3.8	235.0	9.3	201.0	7.9	20.5	0.81	25.5	1.00	40.0	1.57	60.0	2.36	1.0	2.2	P3TKA00CBB	P3TKA00MWB
1/2"	P3TFA24CCAN	97.5	3.8	235.0	9.3	201.0	7.9	20.5	0.81	25.5	1.00	40.0	1.57	60.0	2.36	1.0	2.2	P3TKA00CBB	P3TKA00MWB
3/4"	P3TFA26CDAN	129.0	5.1	275.0	10.8	232.5	9.2	23.0	0.91	28.0	1.10	60.0	2.36	68.0	2.68	2.2	4.8	P3TKA00CBD	P3TKA00MWD
1"	P3TFA28CEAN	129.0	5.1	364.5	14.3	322.0	12.7	23.0	0.91	28.0	1.10	60.0	2.36	68.0	2.68	2.6	5.7	P3TKA00CBD	P3TKA00MWD
1.1/4"	P3TFA2ACEAN	129.0	5.1	364.5	14.3	322.0	12.7	23.0	0.91	28.0	1.10	60.0	2.36	68.0	2.68	2.6	5.7	P3TKA00CBD	P3TKA00MWD
1.1/2"	P3TFA2BCFAN	170.0	6.7	432.5	17.0	382.5	15.1	32.0	1.26	39.0	1.54	84.0	3.31	92.0	3.62	4.5	9.9	P3TKA00CBF	P3TKA00MWF
1.1/2"	P3TFA2BCGAN	170.0	6.7	524.5	20.6	474.5	18.7	32.0	1.26	39.0	1.54	84.0	3.31	92.0	3.62	5.3	11.6	P3TKA00CBF	P3TKA00MWF
2"	P3TFA2CCHAN	170.0	6.7	524.5	20.6	474.5	18.7	32.0	1.26	39.0	1.54	84.0	3.31	92.0	3.62	5.3	11.6	P3TKA00CBF	P3TKA00MWF
2.1/2"	P3TFA2DCJAN	205.0	8.1	641.5	25.3	581.5	22.9	35.5	1.40	42.5	1.67	100.0	3.94	135.0	5.31	10.0	22.0	P3TKA00CBJ	P3TKA00MWJ
3"	P3TFA2ECJAN	205.0	8.1	641.5	25.3	581.5	22.9	35.5	1.40	42.5	1.67	100.0	3.94	135.0	5.31	10.0	22.0	P3TKA00CBJ	P3TKA00MWJ
2.1/2"	P3TFA2DCKAN	205.0	8.1	832.0	32.8	772.0	30.4	35.5	1.40	42.5	1.67	100.0	3.94	135.0	5.31	12.0	26.4	P3TKA00CBJ	P3TKA00MWJ
3"	P3TFA2ECKAN	205.0	8.1	832.0	32.8	772.0	30.4	35.5	1.40	42.5	1.67	100.0	3.94	135.0	5.31	12.0	26.4	P3TKA00CBJ	P3TKA00MWJ

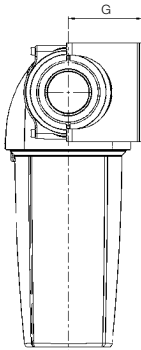
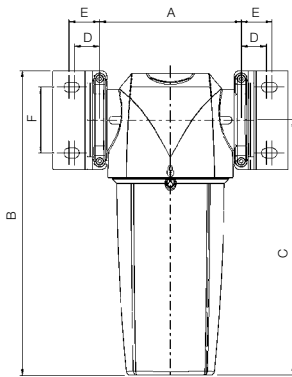

DPI Kit

P3TKA00RQ

Incident Monitor

Used to indicate premature high differential pressure. Indicator can be retrofitted to existing housings without depressurising the system.



Wall Mounting Bracket Kit

Mounting brackets provide additional support to filters installed in flexible piping systems or OEM equipment.



Modular Connection Kit

Fixing clamp allows quick and simple connection of multiple filter housings.

Drain Kits

Auto drain P3TKA00DA

Manual drain P3TKA00DM

1 µm Filtration

Filtration Grade

Filtration type	Coalescing
Particle removal (inc water & oil aerosols)	Down to 1 micron
Max remaining oil content at 21°C	0.06 mg/m ³ 0.05 ppm(w)
Filter efficiency	99.925%
Test methods used	ISO 8573.2 ISO 8573.4 ISO 12500-1
ISO 12500-1 Inlet Challenge concentration	40 mg/m ³
Initial dry differential pressure	<70 mbar (2psi)
Initial saturated differential pressure	<140 mbar (3psi)
Change element every	12 months
Precede with filtration grade	1 micron Moduflex Coalescer



Product selection

Stated flows are for operation at 7 bar (g) with reference to 20°C, 1 bar (a), 0% relative water vapour pressure. For flows at other pressures apply the correction factors shown.

Port Size	Part Number	dm ³ /s	m ³ /hr	cfm	1 µm Replacement Element Kit
1/4"	P3TFA229AAN	10	36	21	P3TKA00ES9A
3/8"	P3TFA239BAN	20	72	42	P3TKA00ES9B
1/2"	P3TFA249CAN	30	108	64	P3TKA00ES9C
3/4"	P3TFA269DAN	60	216	127	P3TKA00ES9D
1"	P3TFA289EAN	110	396	233	P3TKA00ES9E
1.1/4"	P3TFA2A9EAN	110	396	233	P3TKA00ES9E
1.1/2"	P3TFA2B9FAN	160	576	339	P3TKA00ES9F
1.1/2"	P3TFA2B9GAN	220	792	466	P3TKA00ES9G
2"	P3TFA2C9HAN	330	1188	699	P3TKA00ES9H
2.1/2"	P3TFA2D9JAN	430	1548	911	P3TKA00ES9J
3"	P3TFA2E9KAN	430	1548	911	P3TKA00ES9J
2.1/2"	P3TFA2D9KAN	620	2232	1314	P3TKA00ES9K
3"	P3TFA2E9KAN	620	2232	1314	P3TKA00ES9K

Correction factors

Line pressure bar g	psi g	Correction factor
1	15	0.38
2	29	0.53
3	44	0.65
4	58	0.76
5	73	0.85
6	87	0.93
7	100	1.00
8	116	1.07
9	131	1.13
10	145	1.19
11	160	1.25
12	174	1.31
13	189	1.36
14	203	1.41
15	218	1.46
16	232	1.51

Filter selection example

To find the correction factor for 8.5 bar g (122psi g) =

$$\sqrt{\frac{\text{System Operating Pressure}}{\text{Nominal Pressure}}} = \sqrt{\frac{8.5 \text{ bar g}}{7 \text{ bar g}}} = 1.10$$

Selecting a filter model to match a system flow rate and pressure.

Example: System flow 1050 m³/hr at a pressure of 8.5 bar g

1. Obtain pressure correction factor from table or calculate factor using method shown. Correction factor for 8.5 bar g = 1.10
2. Divide system flow by correction factor to give equivalent flow rate at 7 bar g
1050m³/hr ÷ 1.10 = 955 m³/hr (at 7 bar g)
3. Select a filter model from the above table with a flow rate above or equal to 955 m³/hr. Filter model selected : P3TFA2C9HAN
4. Select pipe connection & Thread type System uses 2" piping and BSP threads: Model P3TFA2C9HAN

1 µm Filtration

Technical data

Filter Grade	Drain type	Max operating pressure		Max recommended operating temp.		Min recommended operating temp.	
		bar g	psi g	°C	°F	°C	°F
1 micron	Auto	16	232	80°C	176°F	1.5°C	35°F

Weights and dimensions

Optional Accessories

Port Size	Part Number	A		B		C		D		E		F		G		Weight		Modular Connection Kit	Wall Mounting Bracket Kit
		mm	ins	mm	ins	mm	ins	mm	ins	mm	ins	mm	ins	mm	ins	kg	lbs		
1/4"	P3TFA229AAN	76.0	3.0	181.5	7.2	153.0	6.0	18.0	0.71	24.5	0.96	30.0	1.18	52.0	2.05	0.4	0.9	P3TKA00CBA	P3TKA00MWA
3/8"	P3TFA239BAN	97.5	3.8	235.0	9.3	201.0	7.9	20.5	0.81	25.5	1.00	40.0	1.57	60.0	2.36	1.0	2.2	P3TKA00CBB	P3TKA00MWB
1/2"	P3TFA249CAN	97.5	3.8	235.0	9.3	201.0	7.9	20.5	0.81	25.5	1.00	40.0	1.57	60.0	2.36	1.0	2.2	P3TKA00CBB	P3TKA00MWB
3/4"	P3TFA269DAN	129.0	5.1	275.0	10.8	232.5	9.2	23.0	0.91	28.0	1.10	60.0	2.36	68.0	2.68	2.2	4.8	P3TKA00CBD	P3TKA00MWD
1"	P3TFA289EAN	129.0	5.1	364.5	14.3	322.0	12.7	23.0	0.91	28.0	1.10	60.0	2.36	68.0	2.68	2.6	5.7	P3TKA00CBD	P3TKA00MWD
1.1/4"	P3TFA2A9EAN	129.0	5.1	364.5	14.3	322.0	12.7	23.0	0.91	28.0	1.10	60.0	2.36	68.0	2.68	2.6	5.7	P3TKA00CBD	P3TKA00MWD
1.1/2"	P3TFA2B9FAN	170.0	6.7	432.5	17.0	382.5	15.1	32.0	1.26	39.0	1.54	84.0	3.31	92.0	3.62	4.5	9.9	P3TKA00CBF	P3TKA00MWF
1.1/2"	P3TFA2B9GAN	170.0	6.7	524.5	20.6	474.5	18.7	32.0	1.26	39.0	1.54	84.0	3.31	92.0	3.62	5.3	11.6	P3TKA00CBF	P3TKA00MWF
2"	P3TFA2C9HAN	170.0	6.7	524.5	20.6	474.5	18.7	32.0	1.26	39.0	1.54	84.0	3.31	92.0	3.62	5.3	11.6	P3TKA00CBF	P3TKA00MWF
2.1/2"	P3TFA2D9JAN	205.0	8.1	641.5	25.3	581.5	22.9	35.5	1.40	42.5	1.67	100.0	3.94	135.0	5.31	10.0	22.0	P3TKA00CBJ	P3TKA00MWJ
3"	P3TFA2E9JAN	205.0	8.1	641.5	25.3	581.5	22.9	35.5	1.40	42.5	1.67	100.0	3.94	135.0	5.31	10.0	22.0	P3TKA00CBJ	P3TKA00MWJ
2.1/2"	P3TFA2D9KAN	205.0	8.1	832.0	32.8	772.0	30.4	35.5	1.40	42.5	1.67	100.0	3.94	135.0	5.31	12.0	26.4	P3TKA00CBJ	P3TKA00MWJ
3"	P3TFA2E9KAN	205.0	8.1	832.0	32.8	772.0	30.4	35.5	1.40	42.5	1.67	100.0	3.94	135.0	5.31	12.0	26.4	P3TKA00CBJ	P3TKA00MWJ

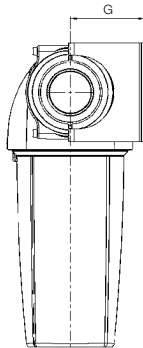
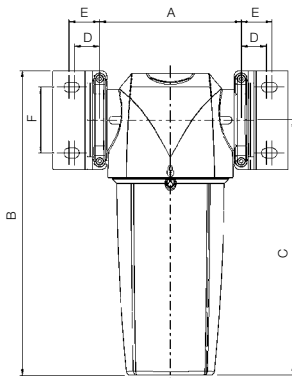

DPI Kit

P3TKA00RQ

Incident Monitor

Used to indicate premature high differential pressure. Indicator can be retrofitted to existing housings without depressurising the system.



Wall Mounting Bracket Kit

Mounting brackets provide additional support to filters installed in flexible piping systems or OEM equipment.



Modular Connection Kit

Fixing clamp allows quick and simple connection of multiple filter housings.

Drain Kits

Auto drain P3TKA00DA

Manual drain P3TKA00DM

Oil Vapour Removal Filter

Filtration Grade

Filtration type	Oil vapour removal
Particle removal (inc water & oil aerosols)	N/A
Max remaining oil content at 21°C	0.003 mg/m ³ 0.003 ppm(w)
Filter efficiency	N/A
Test methods used	ISO 8573.5
ISO 12500-1 Inlet Challenge concentration	N/A
Initial dry differential pressure	<200 mbar (3psi)
Initial saturated differential pressure	N/A
Change element every	When oil vapour is detected
Precede with filtration grade	0.01 micron Moduflex Coalescer filter



Product selection

Stated flows are for operation at 7 bar (g) with reference to 20°C, 1 bar (a), 0% relative water vapour pressure. For flows at other pressures apply the correction factors shown.

Port Size	Part Number	dm ³ /s	m ³ /hr	cfm	Oil vapour removal Replacement Element Kit
1/4"	P3TFA22AAMN	10	36	21	P3TKA00ESAA
3/8"	P3TFA23ABMN	20	72	42	P3TKA00ESAB
1/2"	P3TFA24ACMN	30	108	64	P3TKA00ESAC
3/4"	P3TFA26ADMN	60	216	127	P3TKA00ESAD
1"	P3TFA28AEMN	110	396	233	P3TKA00ESAE
1.1/4"	P3TFA2AAEMN	110	396	233	P3TKA00ESAE
1.1/2"	P3TFA2BAFMN	160	576	339	P3TKA00ESAF
1.1/2"	P3TFA2BAGMN	220	792	466	P3TKA00ESAG
2"	P3TFA2CAHMN	330	1188	699	P3TKA00ESAH
2.1/2"	P3TFA2DAJMN	430	1548	911	P3TKA00ESAJ
3"	P3TFA2EAJMN	430	1548	911	P3TKA00ESAJ
2.1/2"	P3TFA2DAKMN	620	2232	1314	P3TKA00ESAK
3"	P3TFA2EAKMN	620	2232	1314	P3TKA00ESAK

Correction factors

Line pressure bar g	psi g	Correction factor
1	15	0.38
2	29	0.53
3	44	0.65
4	58	0.76
5	73	0.85
6	87	0.93
7	100	1.00
8	116	1.07
9	131	1.13
10	145	1.19
11	160	1.25
12	174	1.31
13	189	1.36
14	203	1.41
15	218	1.46
16	232	1.51
17	247	1.56
18	261	1.60
19	275	1.65
20	290	1.70

To find the correction factor for 8.5 bar g (122psi g) =

$$= \sqrt{\frac{\text{System Operating Pressure}}{\text{Nominal Pressure}}} = \sqrt{\frac{8.5 \text{ bar g}}{7 \text{ bar g}}} = 1.10$$

Filter selection example

Selecting a filter model to match a system flow rate and pressure.

Example: System flow 1050 m³/hr at a pressure of 8.5 bar g

1. Obtain pressure correction factor from table or calculate factor using method shown. Correction factor for 8.5 bar g = 1.10
2. Divide system flow by correction factor to give equivalent flow rate at 7 bar g
1050m³/hr ÷ 1.10 = 955 m³/hr (at 7 bar g)
3. Select a filter model from the above table with a flow rate above or equal to 955 m³/hr. Filter model selected : P3TFA2CAHMN
4. Select pipe connection & Thread type System uses 2" piping and BSP threads: Model P3TFA2CAHMN

Oil Vapour Removal Filter

Technical data

Filter Grade	Drain type	Max operating pressure		Max recommended operating temp.		Min recommended operating temp.	
		bar g	psi g				
Oil vapour removal	Manual	20	290	100°C	212°F	1.5°C	35°F

Weights and dimensions

Optional Accessories

Port Size	Part Number	A		B		C		D		E		F		G		Weight		Modular Connection Kit	Wall Mounting Bracket Kit
		mm	ins	mm	ins	mm	ins	mm	ins	mm	ins	mm	ins	mm	ins	kg	lbs		
1/4"	P3TFA22AAMN	76.0	3.0	181.5	7.2	153.0	6.0	18.0	0.71	24.5	0.96	30.0	1.18	52.0	2.05	0.4	0.9	P3TKA00CBA	P3TKA00MWA
3/8"	P3TFA23ABMN	97.5	3.8	235.0	9.3	201.0	7.9	20.5	0.81	25.5	1.00	40.0	1.57	60.0	2.36	1.0	2.2	P3TKA00CBB	P3TKA00MWB
1/2"	P3TFA24ACMN	97.5	3.8	235.0	9.3	201.0	7.9	20.5	0.81	25.5	1.00	40.0	1.57	60.0	2.36	1.0	2.2	P3TKA00CBB	P3TKA00MWB
3/4"	P3TFA26ADMN	129.0	5.1	275.0	10.8	232.5	9.2	23.0	0.91	28.0	1.10	60.0	2.36	68.0	2.68	2.2	4.8	P3TKA00CBD	P3TKA00MWD
1"	P3TFA28AEMN	129.0	5.1	364.5	14.3	322.0	12.7	23.0	0.91	28.0	1.10	60.0	2.36	68.0	2.68	2.6	5.7	P3TKA00CBD	P3TKA00MWD
1.1/4"	P3TFA2AAEMN	129.0	5.1	364.5	14.3	322.0	12.7	23.0	0.91	28.0	1.10	60.0	2.36	68.0	2.68	2.6	5.7	P3TKA00CBD	P3TKA00MWD
1.1/2"	P3TFA2BAFMN	170.0	6.7	432.5	17.0	382.5	15.1	32.0	1.26	39.0	1.54	84.0	3.31	92.0	3.62	4.5	9.9	P3TKA00CBF	P3TKA00MWF
1.1/2"	P3TFA2BAGMN	170.0	6.7	524.5	20.6	474.5	18.7	32.0	1.26	39.0	1.54	84.0	3.31	92.0	3.62	5.3	11.6	P3TKA00CBF	P3TKA00MWF
2"	P3TFA2CAHMN	170.0	6.7	524.5	20.6	474.5	18.7	32.0	1.26	39.0	1.54	84.0	3.31	92.0	3.62	5.3	11.6	P3TKA00CBF	P3TKA00MWF
2.1/2"	P3TFA2DAJMN	205.0	8.1	641.5	25.3	581.5	22.9	35.5	1.40	42.5	1.67	100.0	3.94	135.0	5.31	10.0	22.0	P3TKA00CBJ	P3TKA00MWJ
3"	P3TFA2EAJMN	205.0	8.1	641.5	25.3	581.5	22.9	35.5	1.40	42.5	1.67	100.0	3.94	135.0	5.31	10.0	22.0	P3TKA00CBJ	P3TKA00MWJ
2.1/2"	P3TFA2DAKMN	205.0	8.1	832.0	32.8	772.0	30.4	35.5	1.40	42.5	1.67	100.0	3.94	135.0	5.31	12.0	26.4	P3TKA00CBJ	P3TKA00MWJ
3"	P3TFA2EAKMN	205.0	8.1	832.0	32.8	772.0	30.4	35.5	1.40	42.5	1.67	100.0	3.94	135.0	5.31	12.0	26.4	P3TKA00CBJ	P3TKA00MWJ

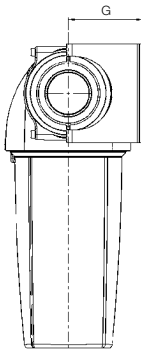
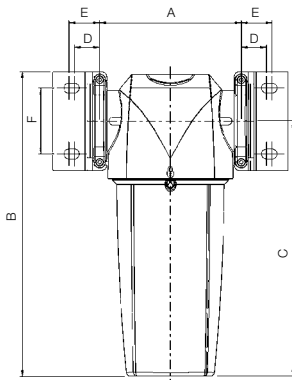

Modular Connection Kit

Fixing clamp allows quick and simple connection of multiple filter housings.



Wall Mounting Bracket Kit

Mounting brackets provide additional support to filters installed in flexible piping systems or OEM equipment.

Drain Kits

Auto drain **P3TKA00DA**

Manual drain **P3TKA00DM**

High Efficiency Bulk Liquid Removal

- Tested in accordance with ISO 8573.9
- Performance independently verified by Lloyds Register
- High liquid removal efficiencies at all flow conditions
- Low pressure losses for low operational costs
- Multiple port sizes for a given flow rate provides increased flexibility during installation
- Suitable for variable flow compressors
- Works with all types of compressor and compressor condensate
- Low maintenance
- 10 Year Housing Guarantee



Typical Applications

- Bulk liquid removal at any point in a compressed air system
- Protection of refrigeration and adsorption dryer pre-filtration
- Liquid removal from compressor inter-coolers / after-coolers
- Liquid separation within refrigeration dryers

Product selection

Stated flows are for operation at 7 bar (g) with reference to 20°C, 1 bar (a), 0% relative water vapour pressure.

Port Size	Part Number	dm³/s	m³/hr	cfm	Max operating pressure		Max Operating temperature		Min Operating temperature	
					bar g	psi g				
1/4"	P3TFA22WAAN	10	36	21	16	232	80 C	176 F	1.5 C	35 F
3/8"	P3TFA23WBAN	40	144	85	16	232	80 C	176 F	1.5 C	35 F
1/2"	P3TFA24WCAN	40	144	85	16	232	80 C	176 F	1.5 C	35 F
3/4"	P3TFA26WDAN	110	396	233	16	232	80 C	176 F	1.5 C	35 F
1"	P3TFA28WEAN	110	396	233	16	232	80 C	176 F	1.5 C	35 F
1.1/4"	P3TFA2AWFAN	350	1260	742	16	232	80 C	176 F	1.5 C	35 F
1.1/2"	P3TFA2BWGAN	350	1260	742	16	232	80 C	176 F	1.5 C	35 F
2"	P3TFA2CWHAN	350	1260	742	16	232	80 C	176 F	1.5 C	35 F
2.1/2"	P3TFA2DWKAN	800	2880	1695	16	232	80 C	176 F	1.5 C	35 F
3"	P3TFA2EWKAN	800	2880	1695	16	232	80 C	176 F	1.5 C	35 F

Correction factors

Line pressure		Correction factor
bar g	psi g	
1	15	0.25
2	29	0.38
3	44	0.50
4	58	0.63
5	73	0.75
6	87	0.88
7	100	1.00
8	116	1.06
9	131	1.12
10	145	1.17
11	160	1.22
12	174	1.27
13	189	1.32
14	203	1.37
15	218	1.41
16	232	1.46

Filter selection example

Selecting a Water Separator model to match a system flow rate and pressure.

Example: System flow 1050 m³/hr at a pressure of 8 bar g

1. Obtain pressure correction factor from table.
Correction factor for 8 bar g = 1.06
2. Divide system flow by correction factor to give equivalent flow rate at 7 bar g
1050m³/hr ÷ 1.06 = 984 m³/hr (at 7 bar g)
3. Select a filter model from the above table with a flow rate above or equal to 984 m³/hr. Suitable Water Separator models : P3TFA2AWFAN
P3TFA2AWGAN
P3TFA2AWHAN
4. Select pipe connection & Thread type
System uses 1.1/2" piping and BSP threads: Model P3TFA2BWGAN

To find the correction factor for 8 bar g =

$$\sqrt{\frac{\text{System Operating Pressure}}{\text{Nominal Pressure}}} = \sqrt{\frac{8 \text{ bar g}}{7 \text{ bar g}}} = 1.06$$

High Efficiency Bulk Liquid Removal

Separation Efficiency

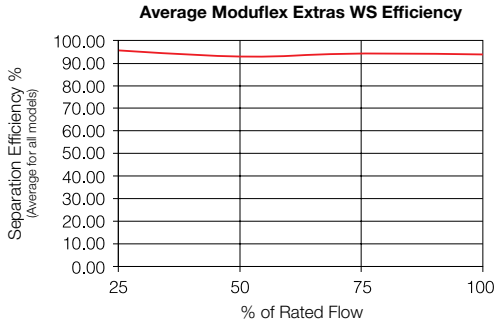

Tested with an inlet challenge concentration of 33ml/m3hr and in accordance with ISO 8573.9.
Performance shown is an average for all models in range. Individual model performance available on request.

Weights and dimensions

Optional Accessories

Port Size	Part Number	A		B		C		D		E		F		G		Weight		Modular Connection Kit	Wall Mounting Bracket Kit
		mm	ins	mm	ins	mm	ins	mm	ins	mm	ins	mm	ins	mm	ins	kg	lbs		
1/4"	P3TFA22WAAN	76.0	3.0	181.5	7.2	153.0	6.0	18.0	0.71	24.5	0.96	30.0	1.18	52.0	2.05	0.4	0.9	P3TKA00CBA	P3TKA00MWA
3/8"	P3TFA23WBAN	97.5	3.8	235.0	9.3	201.0	7.9	20.5	0.81	25.5	1.00	40.0	1.57	60.0	2.36	1.0	2.2	P3TKA00CBB	P3TKA00MWB
1/2"	P3TFA24WCAN	97.5	3.8	235.0	9.3	201.0	7.9	20.5	0.81	25.5	1.00	40.0	1.57	60.0	2.36	1.0	2.2	P3TKA00CBB	P3TKA00MWB
3/4"	P3TFA26WDAN	129.0	5.1	275.0	10.8	232.5	9.2	23.0	0.91	28.0	1.10	60.0	2.36	68.0	2.68	2.2	4.8	P3TKA00CBD	P3TKA00MWD
1"	P3TFA28WEAN	129.0	5.1	364.5	14.3	322.0	12.7	23.0	0.91	28.0	1.10	60.0	2.36	68.0	2.68	2.6	5.7	P3TKA00CBD	P3TKA00MWD
1.1/4"	P3TFA2BWFAN	170.0	6.7	432.5	17.0	382.5	15.1	32.0	1.26	39.0	1.54	84.0	3.31	92.0	3.62	4.5	9.9	P3TKA00CBF	P3TKA00MWF
1.1/2"	P3TFA2BWGAN	170.0	6.7	524.5	20.6	474.5	18.7	32.0	1.26	39.0	1.54	84.0	3.31	92.0	3.62	5.3	11.6	P3TKA00CBF	P3TKA00MWF
2"	P3TFA2CWHAN	170.0	6.7	524.5	20.6	474.5	18.7	32.0	1.26	39.0	1.54	84.0	3.31	92.0	3.62	5.3	11.6	P3TKA00CBF	P3TKA00MWF
2.1/2"	P3TFA2DWKAN	205.0	8.1	832.0	32.8	772.0	30.4	35.5	1.40	42.5	1.67	100.0	3.94	135.0	5.31	12.0	26.4	P3TKA00CBJ	P3TKA00MWJ
3"	P3TFA2EWKAN	205.0	8.1	832.0	32.8	772.0	30.4	35.5	1.40	42.5	1.67	100.0	3.94	135.0	5.31	12.0	26.4	P3TKA00CBJ	P3TKA00MWJ

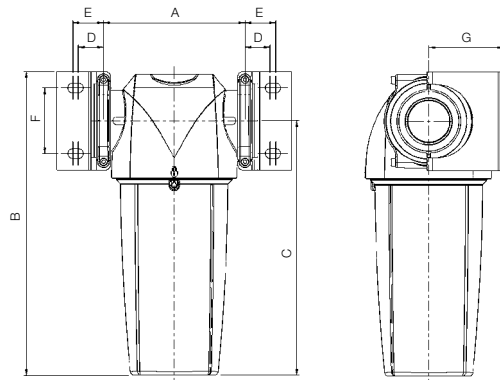

Modular Connection Kit

Fixing clamp allows quick and simple connection of multiple filter housings.



Wall Mounting Bracket Kit

Mounting brackets provide additional support to filters installed in flexible piping systems or OEM equipment.

ISO 8573 - Compressed air quality standards

ISO 8573 is the group of International standards relating to the quality of compressed air and consists of nine separate parts. Part 1 specifies the quality requirements of the compressed air and parts 2 - 9 specify the methods of testing for a range of contaminants.

ISO 8573.1 : 2001 is the primary document used from the ISO 8573 series and it is this document which allows the user to specify the air quality or purity required at key points in a compressed air system.

Within ISO 8573.1 : 2001 purity levels for the main contaminants are shown in separate tables, however for ease of use, this document combines all three into one easy to understand table.

Purity Class	Solid Particulate				Water		Oil	
	Maximum number of particles per m ³			Particle Size micron	Concentration mg/m ³	Vapour Pressure Dewpoint	Liquid g/m ³	Total oil (aerosol, liquid and vapour) mg/m ³
0	*	*	*	*	*	*	*	*
1	100	1	0	-	-	-70°C	-	0.01
2	100,000	1,000	10	-	-	-40°C	-	0.1
3	-	10,000	500	-	-	-20°C	-	1
4	-	-	1,000	-	-	+3°C	-	5
5	-	-	20,000	-	-	+7°C	-	-
6	-	-	-	5	5	+10°C	-	-
7	-	-	-	40	10	-	0.5	-
8	-	-	-	-	-	-	5	-
9	-	-	-	-	-	-	10	-

* As specified by the equipment user or supplier

Specifying air purity in accordance with ISO 8573.1 : 2001

When specifying the purity of air required, the standard must always be referenced, followed by the purity class selected for each contaminant (a different purity class can be selected for each contaminant if required). An example of how to write an air quality specification is shown below :

ISO 8573.1 : 2001 Class 1.2.1 (Example)

ISO8573.1 : 2001 refers to the standard document and its revision, the three digits refer to the purity classifications selected for solid particulate, water and total oil. Selecting an air purity class of 1.2.1 would specify the following air quality when operating at the standard's reference conditions:

Class 1 Particulate

In each cubic metre of compressed air, no more than 100 particles in the 0.1 - 0.5 micron size range are allowed

In each cubic metre of compressed air, no more than 1 particle in the 0.5 - 1 micron size range is allowed

In each cubic metre of compressed air, no particles in the 1 - 5 micron size range are allowed

Class 2 Water

A pressure dewpoint of -40°C or better is required and no liquid water is allowed.

Class 1 Oil

In each cubic metre of compressed air, not more than 0.01mg of oil is allowed. This is a combined level for both oil aerosol and oil vapour.

Cost effective system design

To achieve the stringent air quality levels required for today's modern production facilities, a careful approach to system design, commissioning and operation must be employed. Treatment at one point alone is not enough and it is highly recommended that the compressed air is treated prior to entry into the distribution system to a quality level suitable for protecting air receivers and distribution piping.

The following table highlights the Moduflex Extras filtration and drying products required to achieve each air purity classification shown in ISO 8573.1 : 2001.

Point of use purification should also be employed, with specific attention being focused on the application and the level of air quality required. This approach to system design ensures that air is not "over treated" and provides the most cost effective solution to high quality compressed air.

ISO 8573.1:2001 Class	Solid Particulate	Water Vapour	Total Oil (Aerosol Liquid & Vapour)
1	Coalescing Grade 1µm filter + Grade 0.01µm filter + Sterile filter	Moduflex Adsorption Dryer -70°C PDP	Coalescing Grade 0.01µm filter + Grade 1µm filter + Vapour removal filter
2	Coalescing Grade 1µm filter + Grade 0.01µm filter	Moduflex Adsorption Dryer -40°C PDP	Coalescing Grade 0.01µm filter + Grade 1µm filter
3	Coalescing Grade 1µm filter		Coalescing Grade 1µm filter