

**Contents**

Series	Description	Size						Mounting			Operation		Page
		06	10	06	10	25	32	Subplate	Panel	Screw-in	Direct	Pilot	
	Parker Standard DIN / ISO												
<b>Pressure relief valves, manual operation</b>													
VS				•				•			•		4-2
VB				•	•			•			•		4-5
VBY				•	•			•				•	4-10
EVSA		•	•							•	•		4-15
R1E02	Remote control valve	•						•	•		•		4-18
R4V/R6V					•	•	•	•				•	4-21
R4V/R6V	According to directive 97/23/EG (TÜV)				•	•	•	•				•	4-30
<b>Pressure relief valves, proportional operation</b>													
RE06M*W				•				•			•		4-39
RE06M*T				•				•			•		4-43
R4V/R6V					•	•	•	•				•	4-49
R4V/R6V	Onboard electronics				•	•	•	•				•	4-55
VBY*K				•	•			•				•	4-63
<b>Unloading and sequence valves, manual operation</b>													
R4U					•	•	•	•				•	4-69
R4S					•	•	•	•				•	4-75
<b>Pressure reducing valves, manual operation</b>													
VM				•	•			•			•		4-78
R4R					•	•	•	•				•	4-83
<b>Pressure reducing valves, proportional operation</b>													
VMY				•	•			•				•	4-87
R4R					•	•	•	•				•	4-95
<b>Accessories</b>													
	Plug-in connectors												4-99

More pressure valves are presented in the following chapters:

- Chapter 7: Sandwich Valves
- Chapter 8: Slip-In Cartridge Valves
- Chapter 9: SAE Flange Valves
- Chapter 10: Valves for Pipe Mounting

**Characteristics / Ordering Code**

The pressure relief valve series VS is a direct operated spool valve for subplate mounting. The connection and function is according to ISO 6264.

**Function**

- Spool type valve
- Subplate mounting according to ISO 6264
- 5 pressure stages
- 2 adjustment modes
- Gauge port

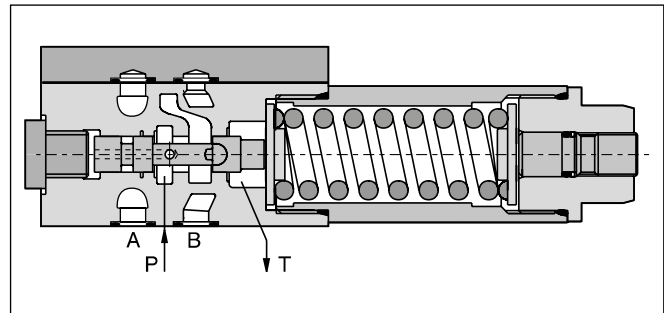
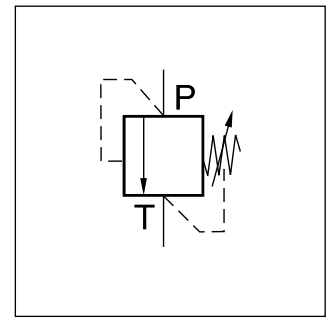

4

**Ordering code**

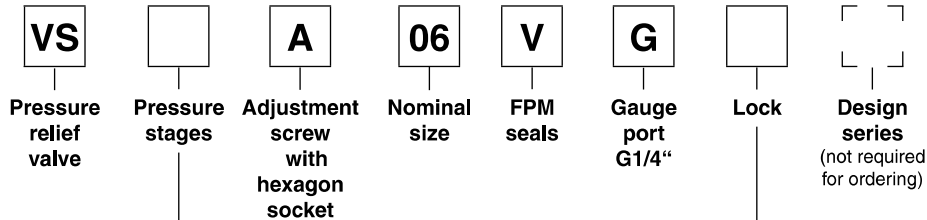

Code	Pressure stages
025	up to 25 bar
<b>064</b>	<b>up to 64 bar</b>
<b>160</b>	<b>up to 160 bar</b>
<b>210</b>	<b>up to 210 bar</b>
350	up to 350 bar

Code	Lock
<b>omit</b>	-
Z	Cylinder lock

**Bold letters = Short-term availability**

**Technical data**

General		
Design		Direct operated relief valve spool type
Nominal size		DIN NG06 / CETOP 03 / NFPA D03
Interface		Subplate mounting according to ISO 6264
Mounting position		unrestricted
Ambient temperature	[°C]	-20...+60
MTTF <sub>D</sub> value	[years]	150
Weight	[kg]	1.3
Hydraulic		
Max. operating pressure	[bar]	Port P 350, Port T depressurized
Pressure stages	[bar]	25, 64, 160, 210, 350
Nominal flow	[l/min]	25
Fluid		Hydraulic oil according to DIN 51524
Fluid temperature	[°C]	-20...+70
Viscosity permitted	[cSt] / [mm <sup>2</sup> /s]	20...400
Viscosity recommended	[cSt] / [mm <sup>2</sup> /s]	30...80
Filtration		ISO 4406 (1999); 18/16/13

**p/Q performance curves**

**Pressure stage 25 bar**

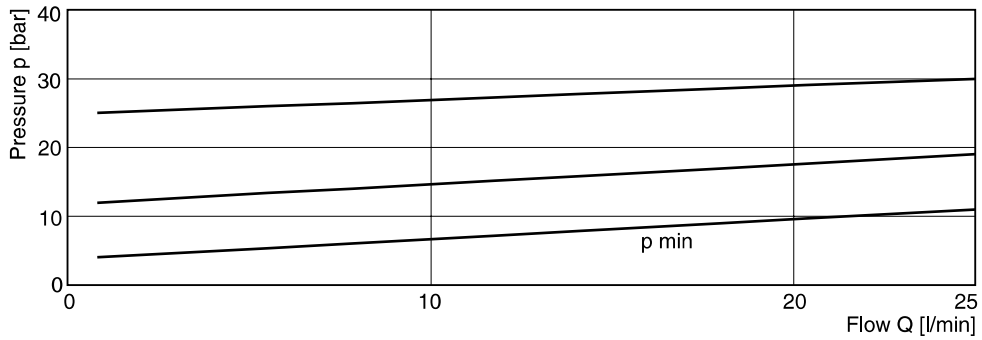

**Pressure stage 64 bar**

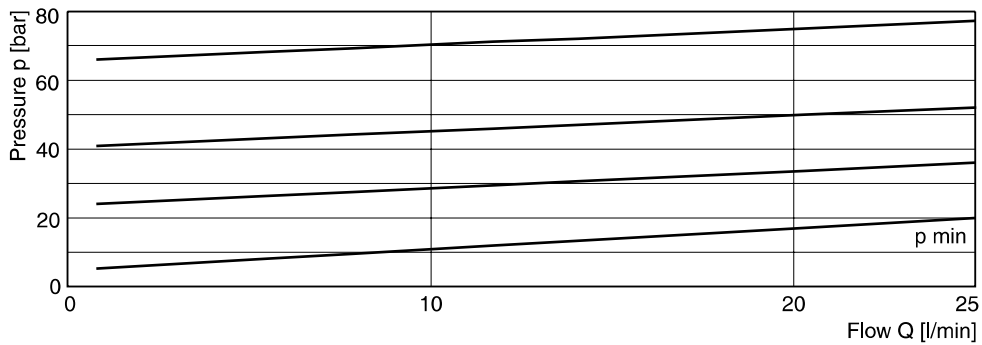

**Pressure stage 160, 210 and 350 bar**

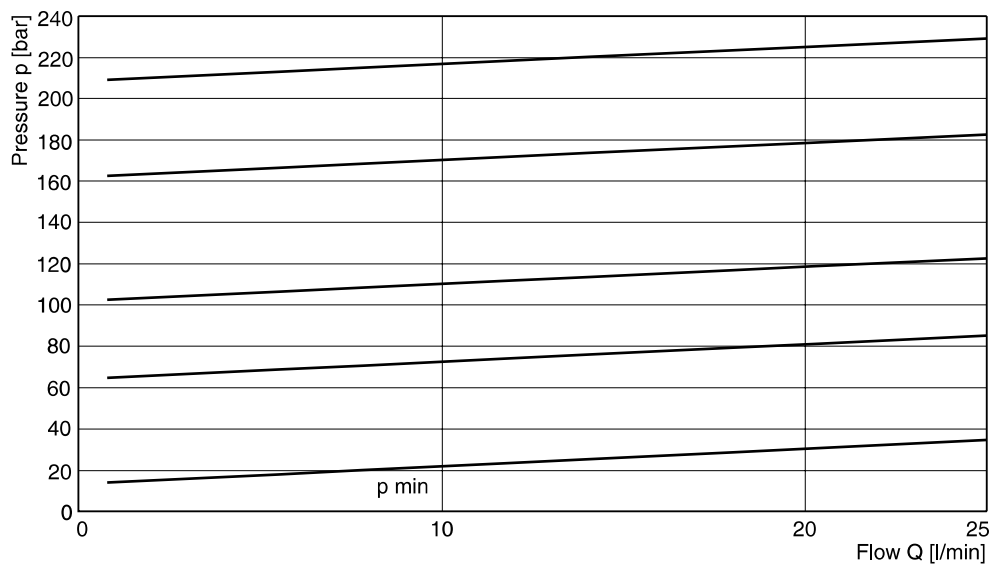

All characteristic curves measured with HLP46 at 50 °C.



VS UK.indd 25.04.2019

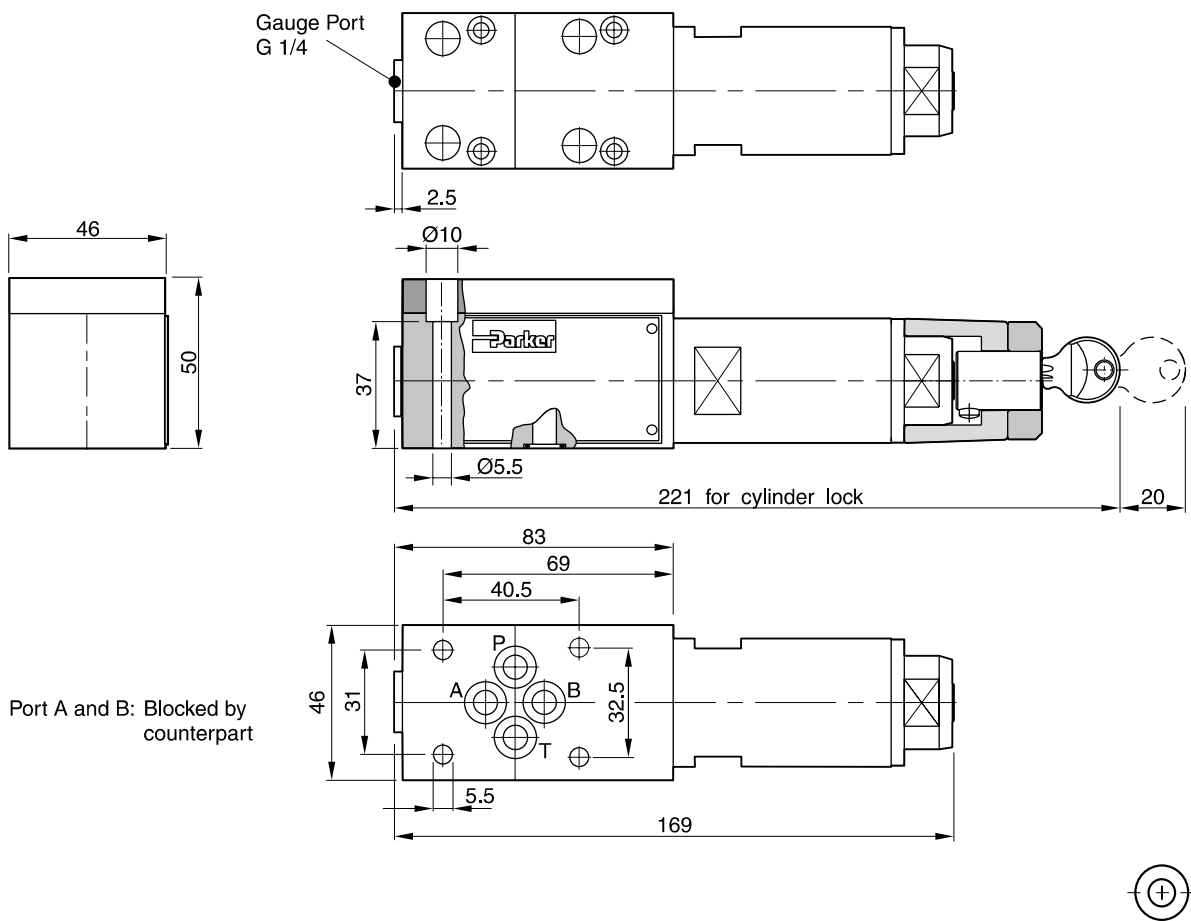

Dimensions

4

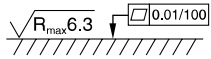

Surface finish	Bolt kit			 Kit FPM
	BK443	4x M5x45 ISO 4762-12.9	7.6 Nm ±15 %	SK-VB/VM/VS-A06V

Mounting pattern ISO 6264, code 6264-03-04-\*-97

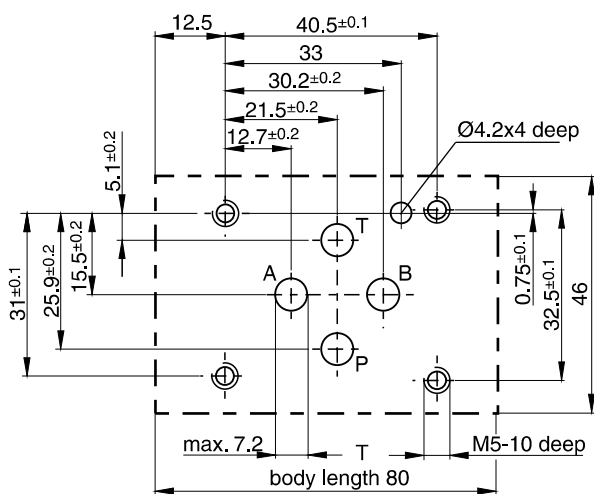

Direct operated pressure relief valve with manual adjustment. The series VB can also be used as a pressure sequence valve, because of the high pressure capability in the outlet port and the external drain port.

**Features**

- Spool type valve
- Subplate mounting according to ISO 5781
- 5 pressure stages at NG06
- 3 pressure stages at NG10
- 2 adjustment modes



VB\*A10

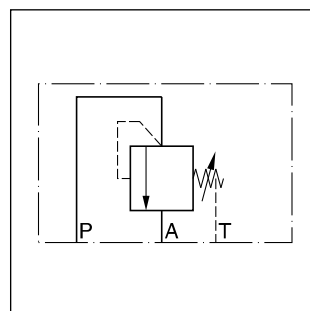

VB\*A06

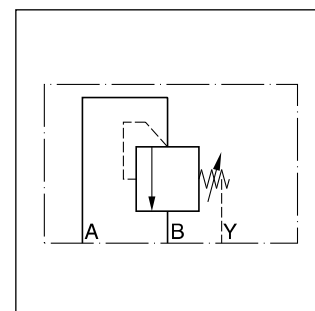

VB\*A10

**VB\*A06**

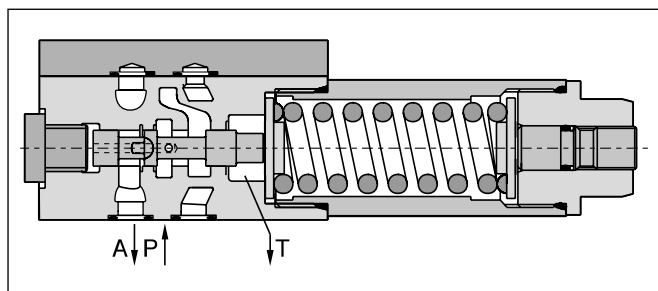

**VB\*A10**

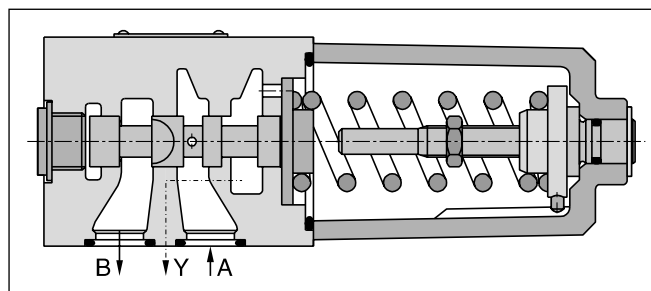

**Ordering code**

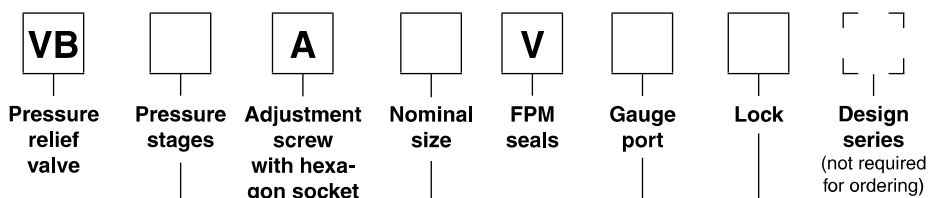

Code	Pressure stages
025 <sup>1)</sup>	up to 25 bar
<b>064</b>	<b>up to 64 bar</b>
<b>125</b> <sup>2)</sup>	<b>up to 125 bar</b>
<b>160</b> <sup>1)</sup>	<b>up to 160 bar</b>
<b>210</b>	<b>up to 210 bar</b>
350 <sup>1)</sup>	up to 350 bar

Code	Lock
<b>omit</b>	-
Z	Cylinder lock

Code	Nominal size
<b>06</b>	<b>NG06</b>
<b>10</b>	<b>NG10</b>

Code	Gauge port
<b>G</b> <sup>1)</sup>	<b>G 1/4"</b>
<b>M</b> <sup>2)</sup>	<b>M18x1.5</b>

**Bold letters =  
Short-term availability**

<sup>1)</sup> Only NG06.  
<sup>2)</sup> Only NG10.



**Technical Data**

<b>General</b>			
Design	Direct operated pressure relief valve, spool type		
Nominal size	<b>NG06 (CETOP 03 / NFPA D03)</b>	<b>NG10 (CETOP 05 / NFPA D05)</b>	
Interface	Subplate mounting according to ISO 5781		
Mounting position	unrestricted		
Ambient temperature	[°C]	-20...+60	
MTTF <sub>D</sub> value	[years]	150	
Weight	[kg]	1.3	3.7
<b>Hydraulic</b>			
Max. operating pressure	[bar]	Port P and A 350 Port T depressurized	Port A and B 350 Port Y depressurized
Pressure stages	[bar]	25, 64, 160, 210, 350	64, 125, 210
Nominal flow	[l/min]	25	60
Fluid	Hydraulic oil according to DIN 51524		
Fluid temperature	[°C]	-20...+70	
Viscosity permitted	[cSt] / [mm <sup>2</sup> /s]	20...400	
Viscosity recommended	[cSt] / [mm <sup>2</sup> /s]	30...80	
Filtration	ISO 4406 (1999); 18/16/13		

4

**p/Q performance curves**

**VB\*06**

**Setting pressure max. 25 bar**

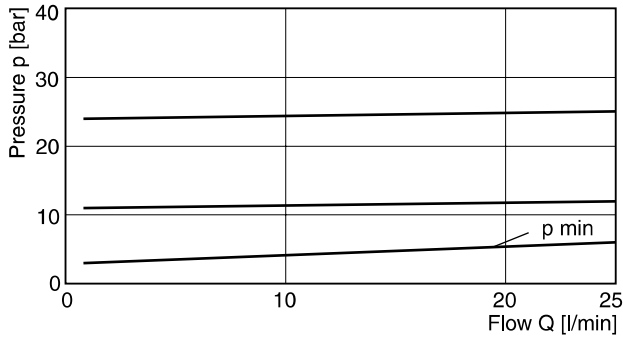

**Setting pressure max. 64 bar**

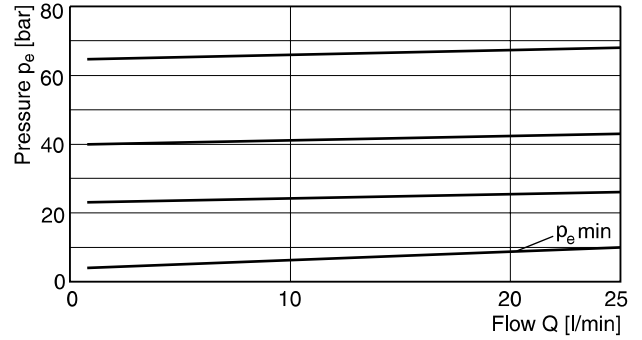

**Setting pressure max. 160 or 210 bar**

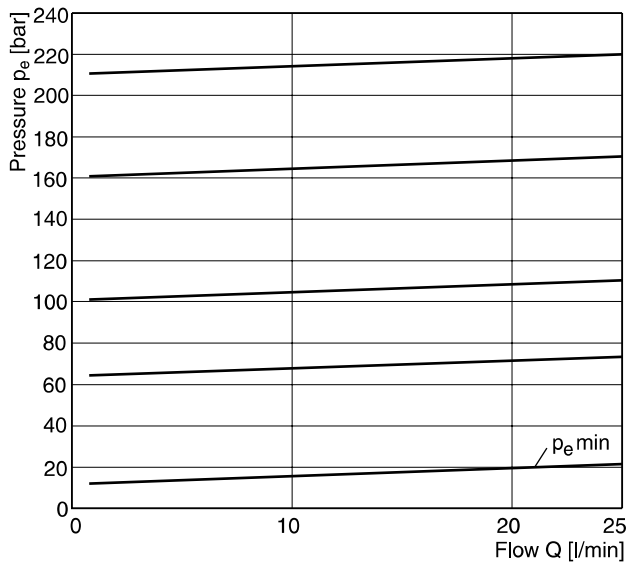

**VB\*10**

**Setting pressure max. 64 bar**

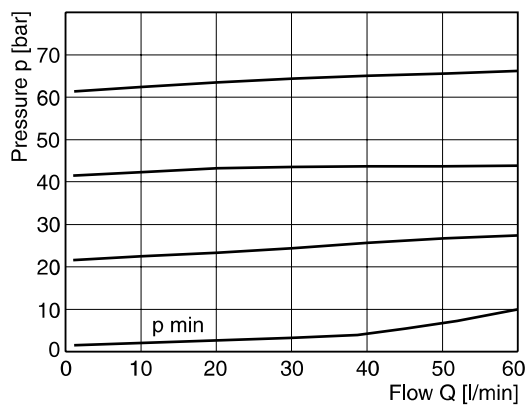

**Setting pressure max. 210 bar**

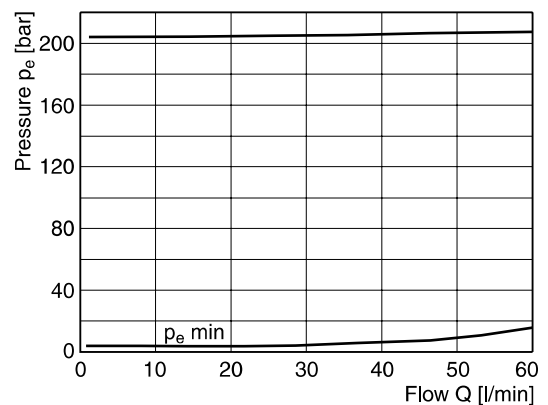

All characteristic curves measured with HLP46 at 50 °C.



VB UK.indd 25.04.2019

Dimensions

NG06

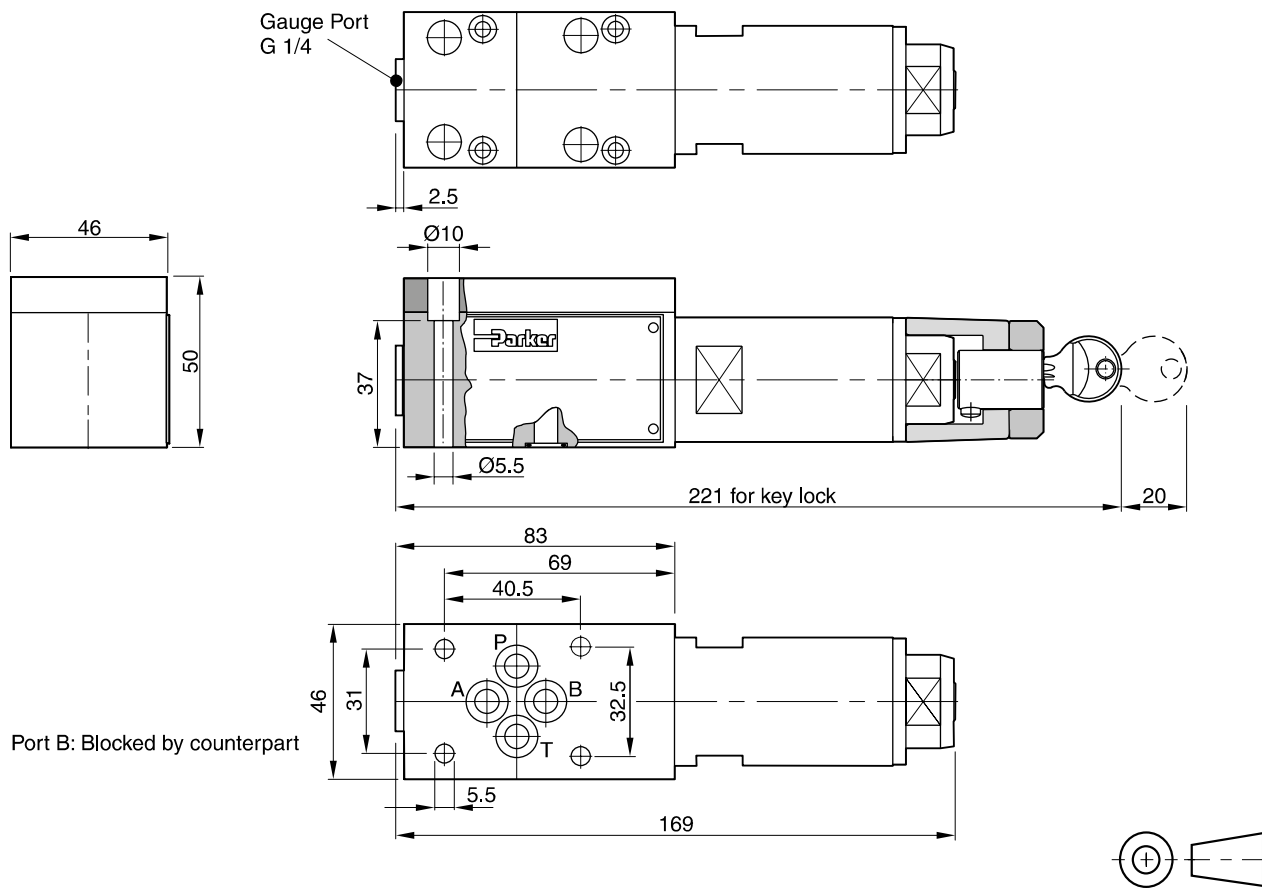
4

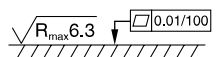

Surface finish	Bolt kit			
	BK443	4x M5x45 ISO 4762-12.9	7.6 Nm ±15 %	SK-VB/VM/VS-A06V

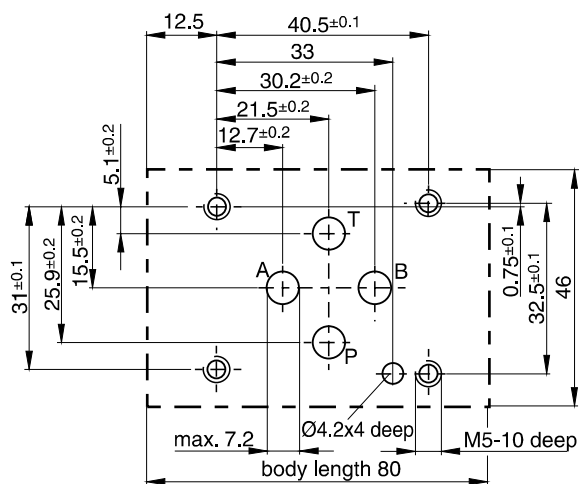

Mounting pattern ISO 5781-03-04-00



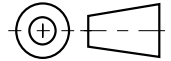
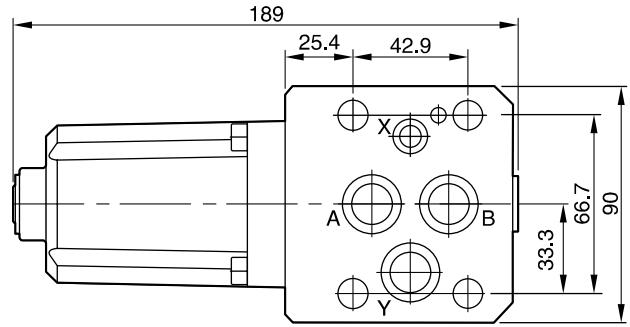
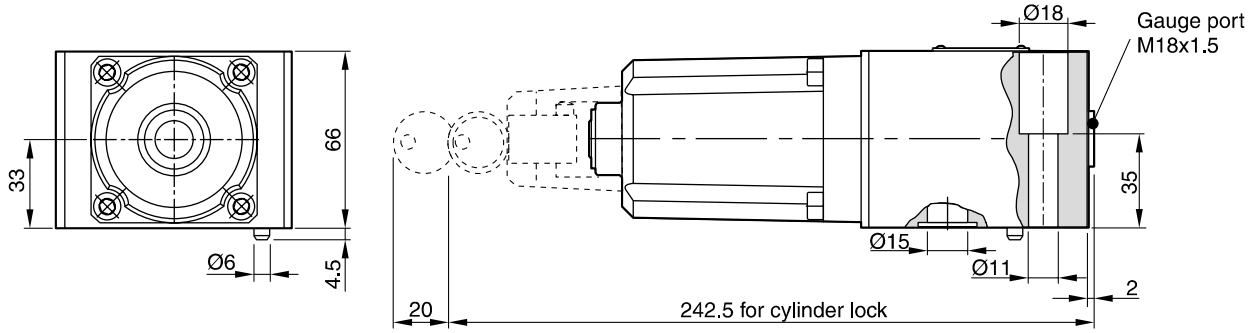

**NG10**

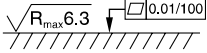

Surface finish	Bolt kit			 Kit FPM
	BK389	4x M10x50 ISO 4762-12.9	63 Nm ±15 %	SK-VB/VM-A10V

**Mounting pattern ISO 5781-06-07-0-00 <sup>1)</sup>**

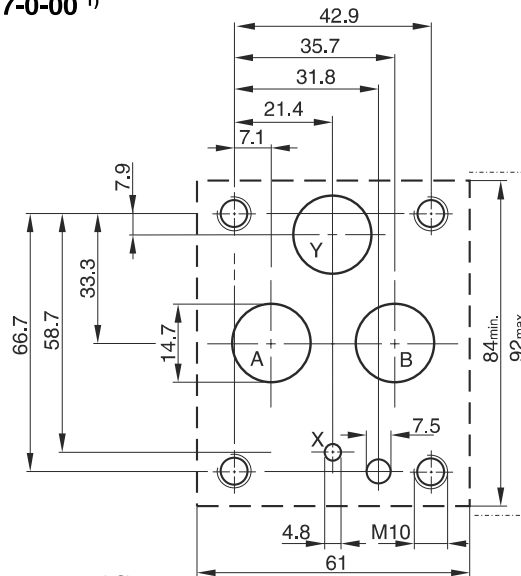

<sup>1)</sup> Deviating from ISO the Y port has Ø 14.7 instead of Ø 4.8.

**Characteristics**

Pilot operated relief valves of the series VBY consist of a pilot with manual adjustment and a spool type main stage. The valves need to be externally drained.

The series VBY can also be used as pressure sequence valve, because of the high pressure capability in the outlet port and the external drain port.

**Features**

- Subplate mounting acc. to ISO 5781
- Main stage spool type
- Pilot stage seated type
- 4 pressure stages
- 2 adjustment modes:
  - screw with hexagon socket
  - cylinder lock

4



VBY\*A06



VBY\*A10

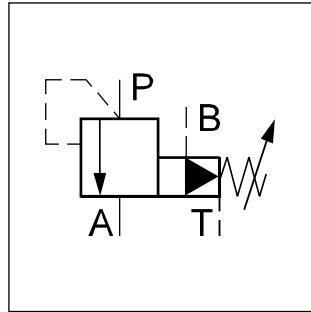

VBY\*A06

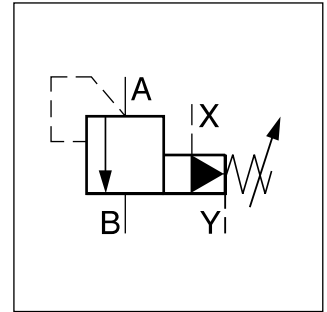

VBY\*A10

**VBY\*A06**

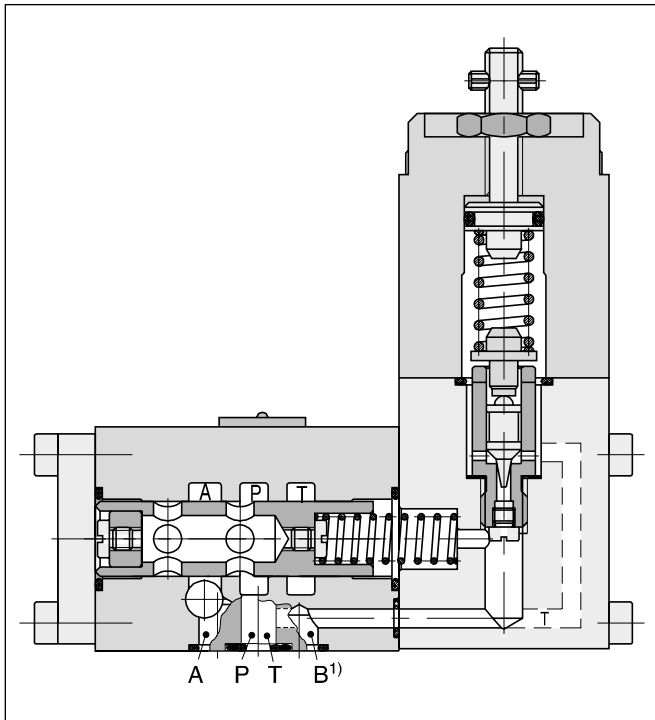

**VBY\*A10**

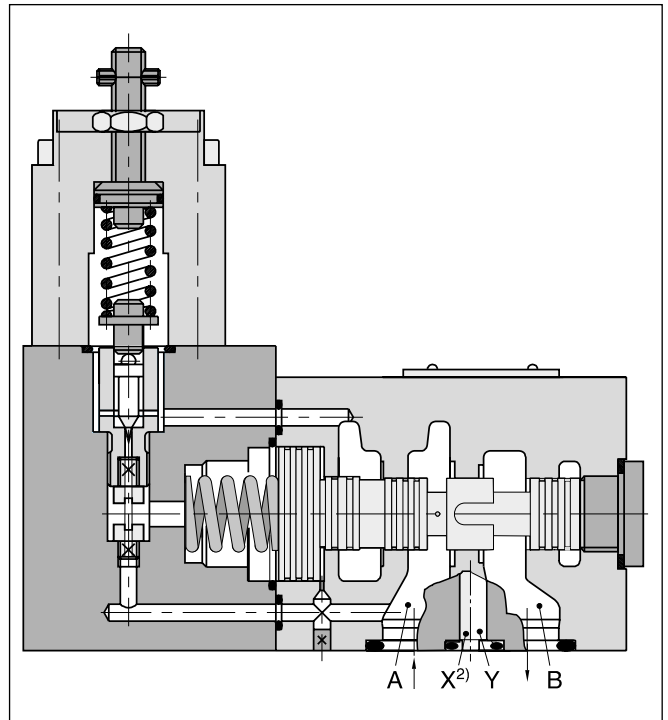

1) Port B for remote control, otherwise to be blocked.  
2) Port X for remote control, otherwise to be blocked.

**Ordering code**

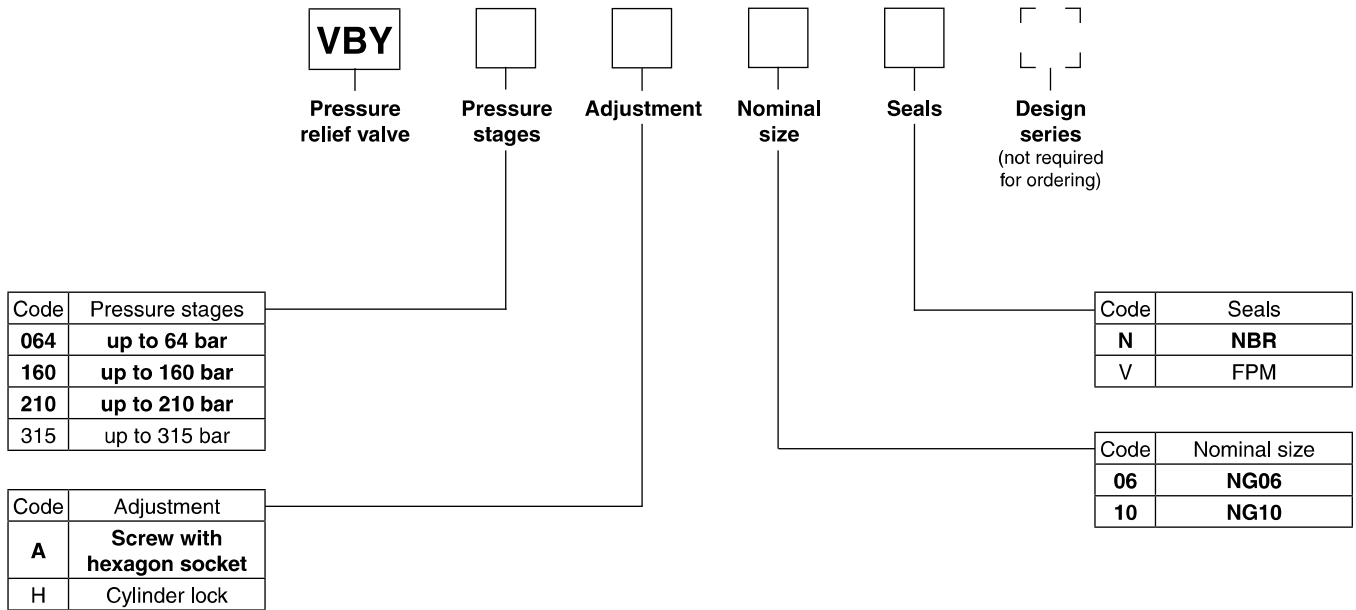

**Bold letters =  
Short-term availability**

**Technical data**

General			
Design	Pilot operated pressure relief valve, spool type		
Nominal size	<b>NG06</b>	<b>NG10</b>	
Interface	Subplate mounting according to ISO 5781		
Mounting position	unrestricted		
Ambient temperature	[°C]	-20...+60	
MTTF <sub>d</sub> value	[years]	75	
Weight	[kg]	2.4	4.5
Hydraulic			
Max. operating pressure	[bar]	P, A 315, B blocked	A, B 350, X blocked
External drain port pressure	[bar]	T 100	Y 100
Pressure stages	[bar]	64, 160, 210, 315	
Fluid	Hydraulic oil according to DIN 51524		
Fluid temperature	[°C]	-20...+70 (NBR: -25...+70)	
Viscosity, permitted	[cSt] / [mm <sup>2</sup> /s]	20...400	
	recommended	[cSt] / [mm <sup>2</sup> /s]	30...80
Filtration	ISO 4406 (1999); 18/16/13		
Nominal flow	[l/min]	See p/Q curves	
Pilot oil flow	[cm <sup>3</sup> /min]	approx. 500	approx. 1000

**p/Q performance curves NG06**

**Max. 64 bar**

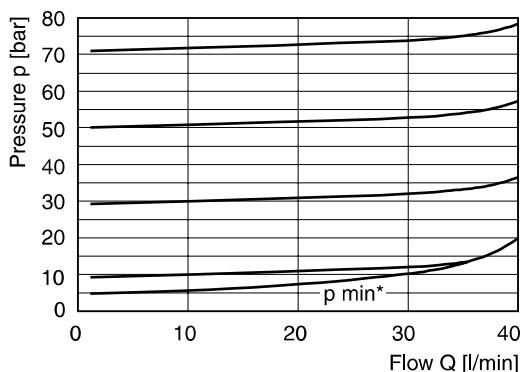

**Max. 160 bar**

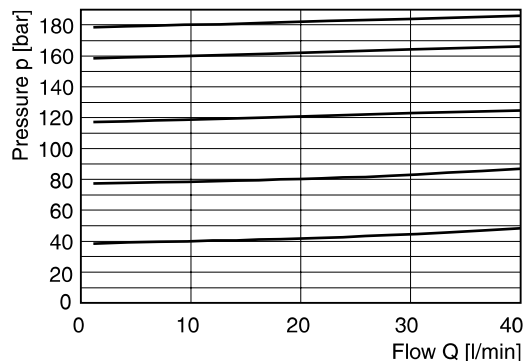

**Max. 210 bar**

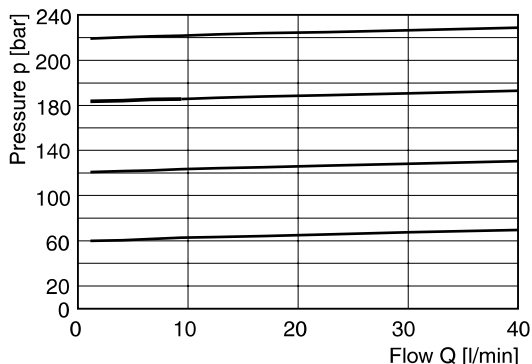

**Max. 315 bar**

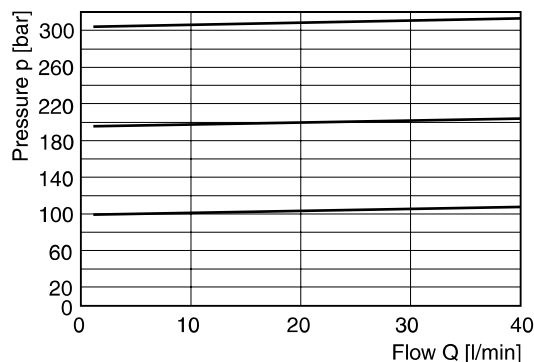

**p/Q performance curves NG10**

**Max. 64 bar**

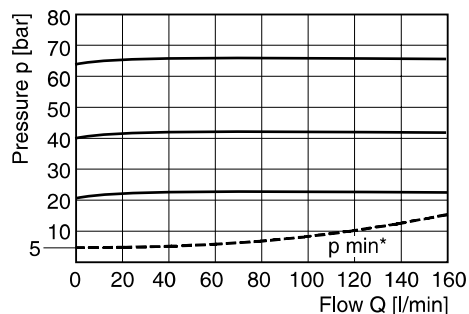

**Max. 160 bar**

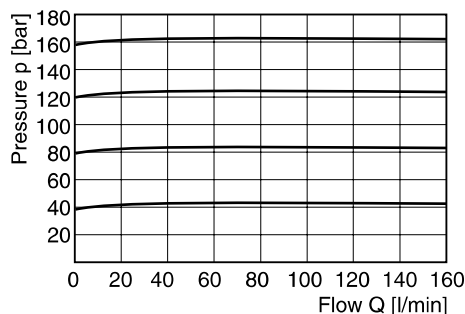

**Max. 210 bar**

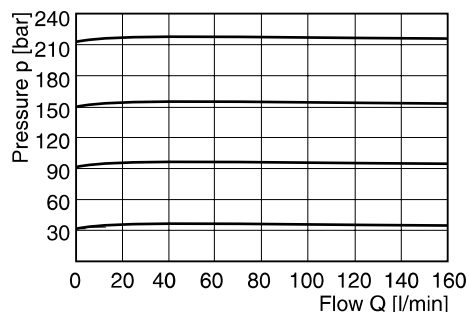

**Max. 315 bar**

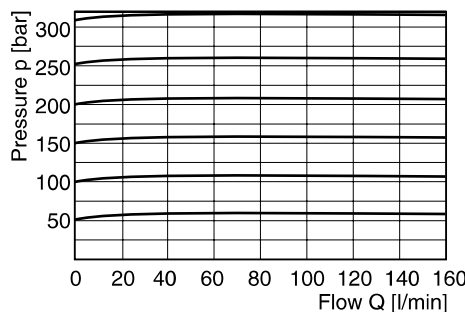

All characteristic curves measured with HLP46 at 50 °C.

\* For all pressure stages.

VBV UK.indd 25.04.2019



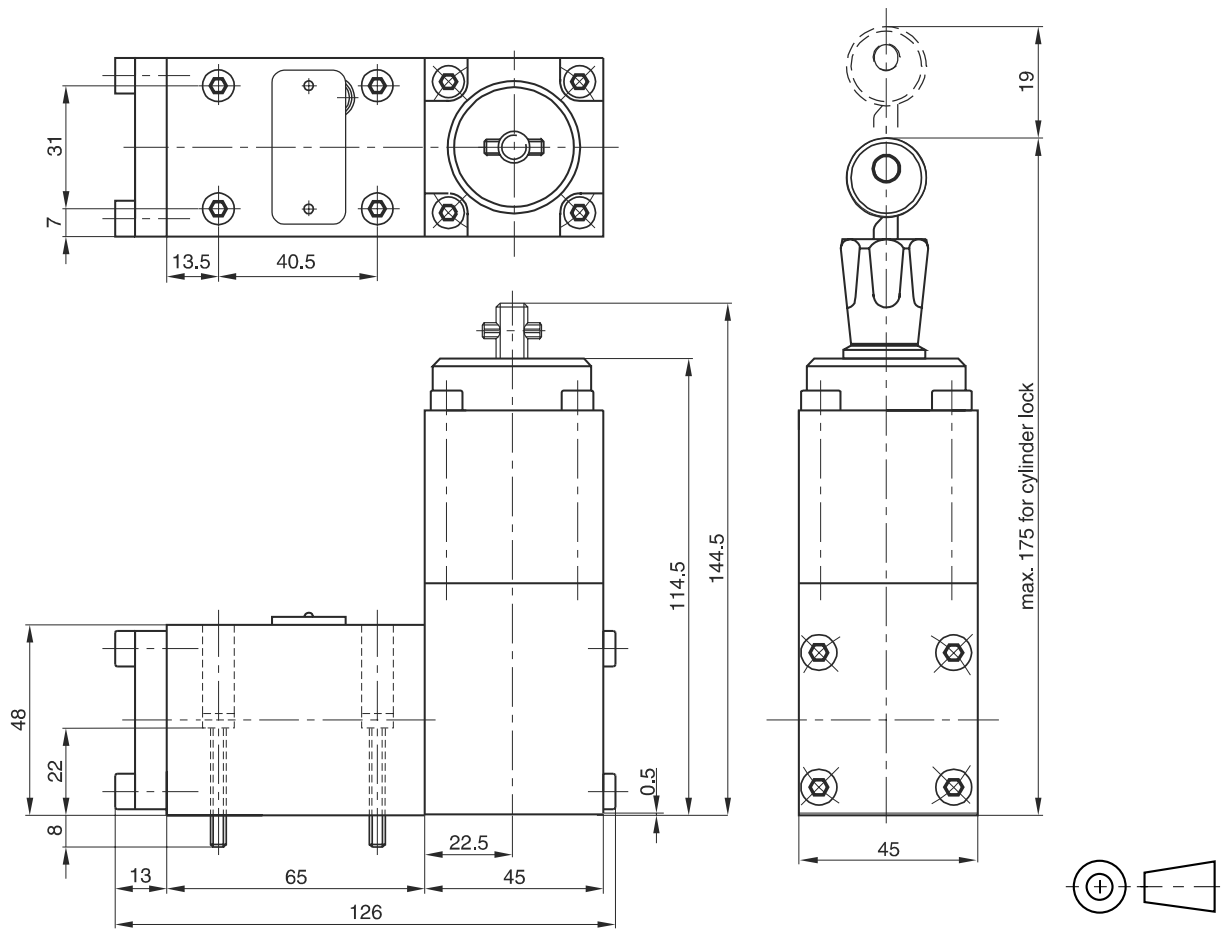

4

**NG06**

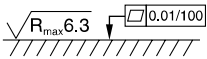

**4**

Surface finish	Bolt kit			
	BK375	4x M5x30 ISO 4762-12.9	7.6 Nm ±15 %	SK-VBY-A06V

**Mounting pattern ISO 5781-03-04-0-00**

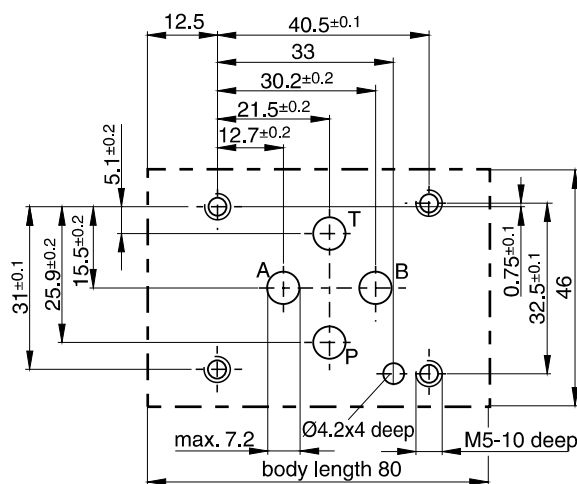



Dimensions

NG10

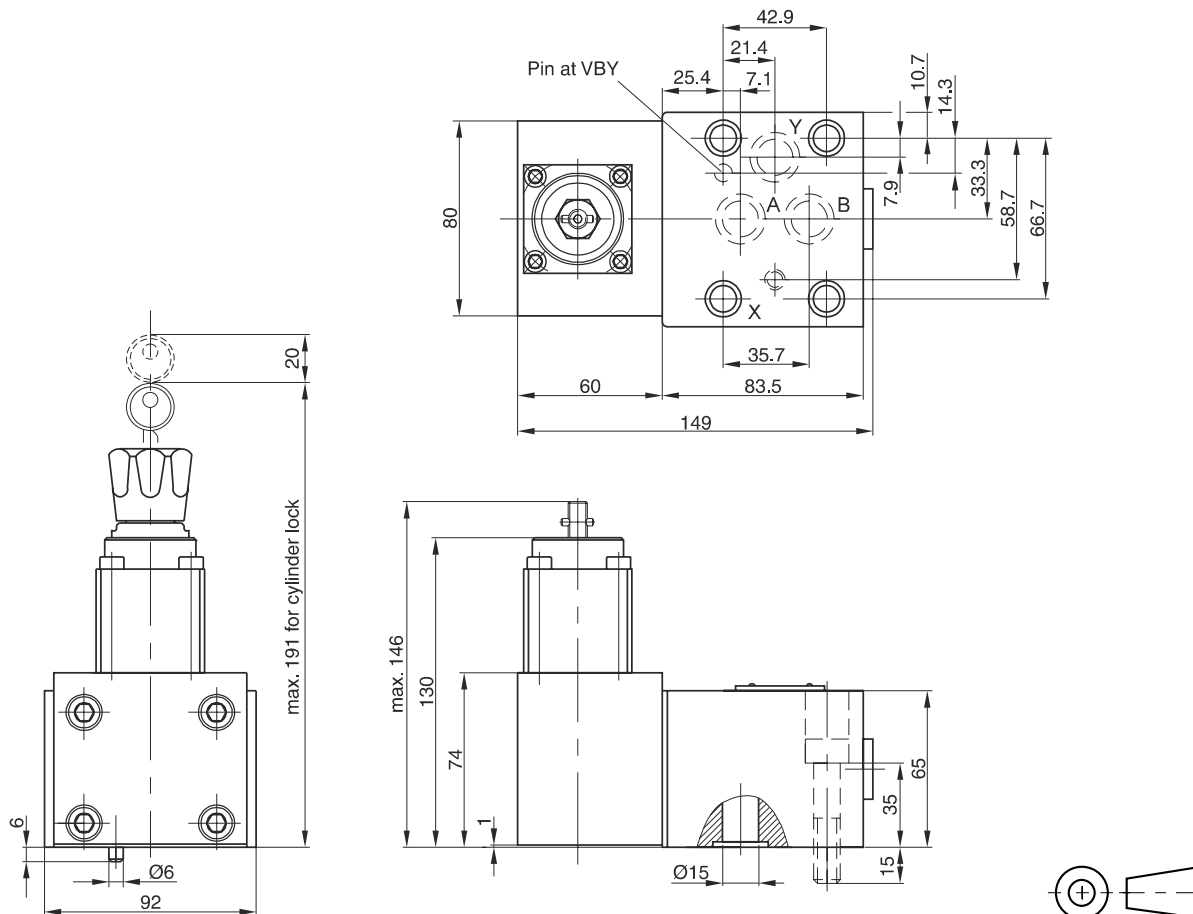
4

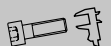

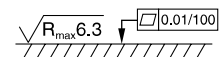
Surface finish	Bolt kit			
	BK389	4x M10x50 ISO 4762-12.9	63 Nm ±15 %	SK-VB/VM-A10V

Mounting pattern ISO 5781-06-07-0-00 <sup>1)</sup>

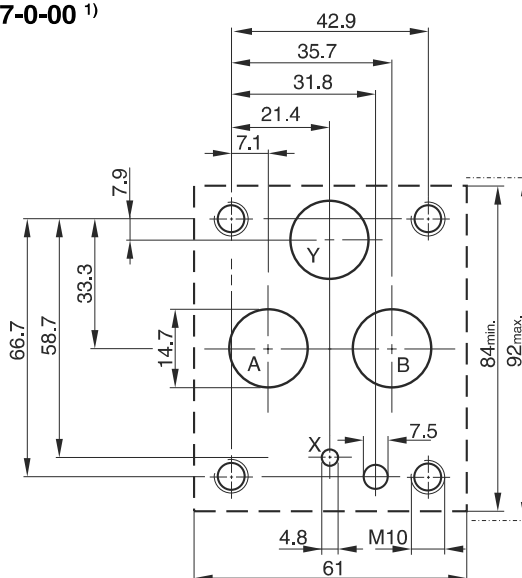

<sup>1)</sup> Deviating from ISO the Y port has Ø 14.7 instead of Ø 4.8.

The direct operated pressure relief valve series EVSA is a seated type valve for screw-in mounting. It is available in two sizes and three pressure stages.

**Function**

When the pressure in port P exceeds the setting pressure the cone opens to port T and thus limits the pressure in port P to the adjusted level.

The integrated damping spool prevents pressure fluctuations in the transition region. The pressure is set by the adjusting screw, which is locked by the clamping screw. The setting can optionally be secured by a cylinder lock.

**Features**

- Seated type valve
- Screw-in mounting
- 3 pressure stages
- 2 adjustment modes:
  - screw with hexagon socket
  - cylinder lock

**Note**

The spring must be unloaded when the EVSA is screwed out of the manifold.

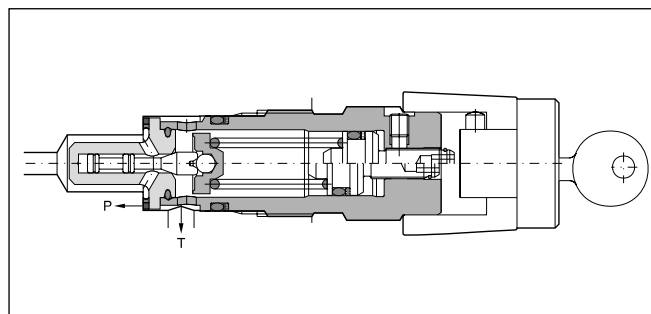
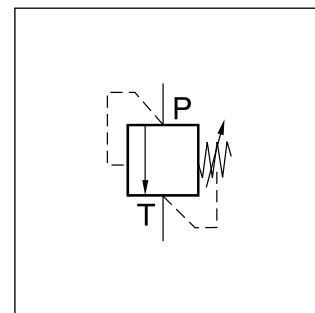

4

**Ordering code**

<b>EVSA</b>		<b>A</b>		<b>1</b>		
Pressure relief valve	Pressure stages	Adjustment screw with hex. socket	Nominal size / thread type	FPM Seals	Design series <small>(not required for ordering)</small>	Lock

<b>Code</b>	<b>Pressure stages</b>
<b>064</b>	<b>up to 64 bar</b>
<b>160</b>	<b>up to 160 bar</b>
<b>315</b>	<b>up to 315 bar</b>

<b>Code</b>	<b>Lock</b>
<b>omit</b>	<b>-</b>
<b>Z</b>	<b>Cylinder lock</b>

<b>Code</b>	<b>Nominal size</b>
<b>06</b>	<b>NG06, M28x1.5</b>
<b>10</b>	<b>NG10, M35x1.5</b>

**Bold letters = Short-term availability**

**Technical data**

General	
Design	Direct operated relief valve, seated type
Nominal size	<b>NG06</b> <b>NG10</b>
Interface	Screw-in mounting
Mounting position	unrestricted
Ambient temperature	[°C] -20...+60
MTTF <sub>D</sub> value	[years] 150
Weight	[kg]                      0.3                      0.45
Hydraulics	
Max. operating pressure	[bar] Port P 315, Port T depressurized
Pressure stages	[bar] 64, 160, 315
Nominal flow	[l/min] 40 (NG06), 80 (NG10)
Fluid	Hydraulic oil according to DIN 51524
Fluid temperature	[°C] -20...+70
Viscosity permitted	[cSt] / [mm²/s] 20...400
recommended	[cSt] / [mm²/s] 30...80
Filtration	ISO 4406 (1999); 18/16/13

$\Delta p/Q$  performance curves

**NG06 pressure stage 64 bar**

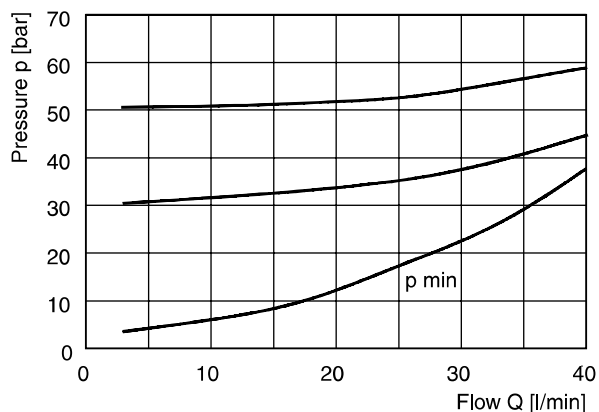

**NG10 pressure stage 64 bar**

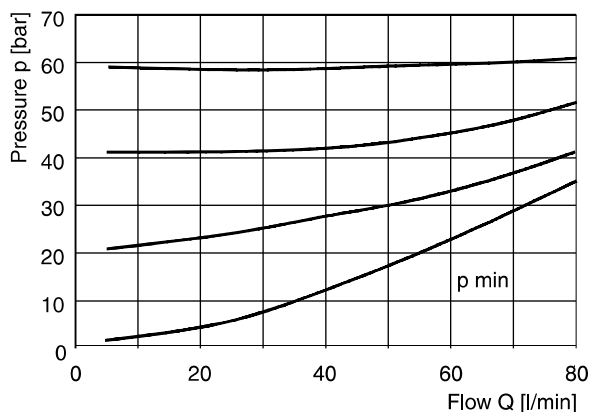

**NG06 pressure stage 160 bar**

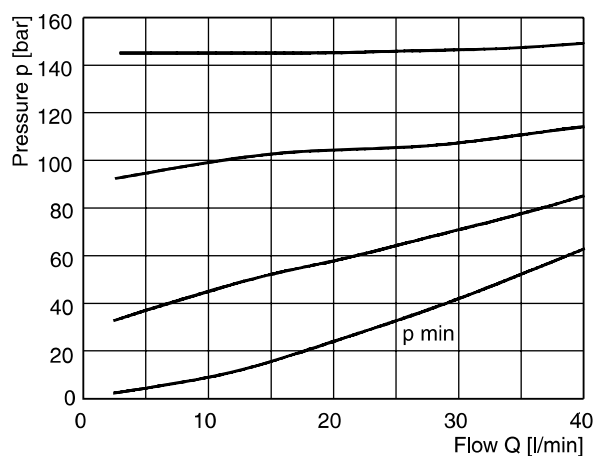

**NG10 pressure stage 160 bar**

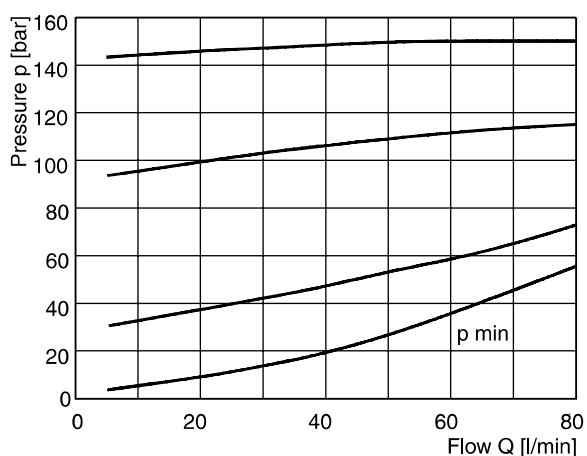

**NG06 pressure stage 315 bar**

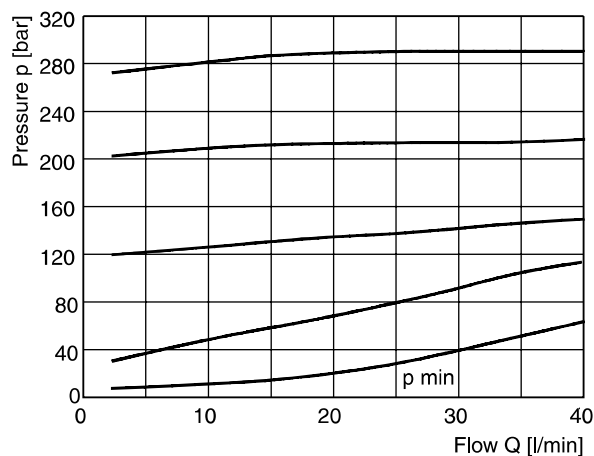

**NG10 pressure stage 315 bar**

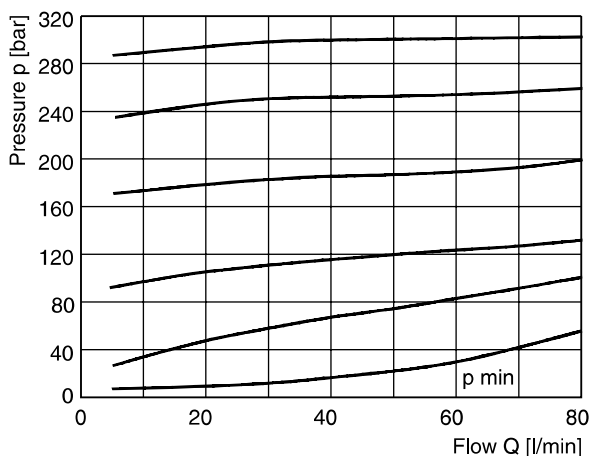

All characteristic curves measured with HLP46 at 50 °C.

4



Dimensions

NG06

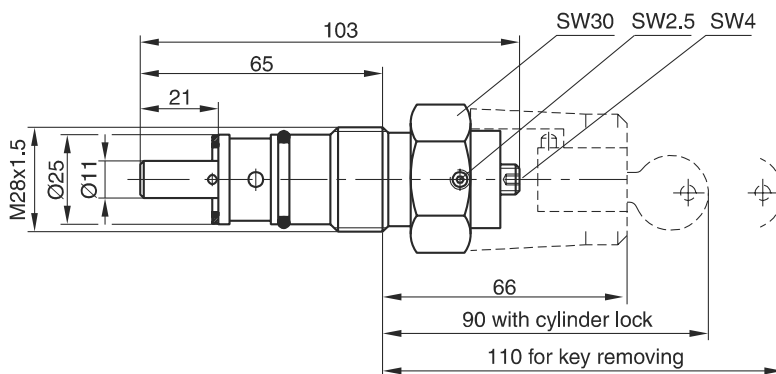

○ Kit  
SK-EVSA0613

NG10

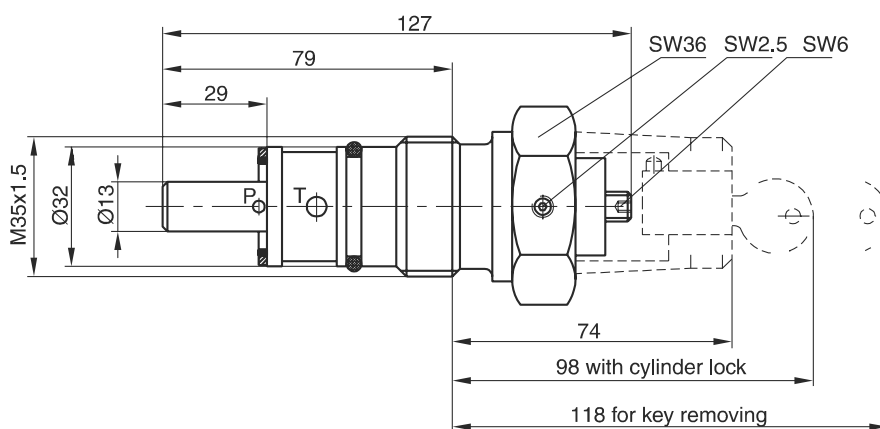

○ Kit  
SK-EVSA0103

Installation dimensions

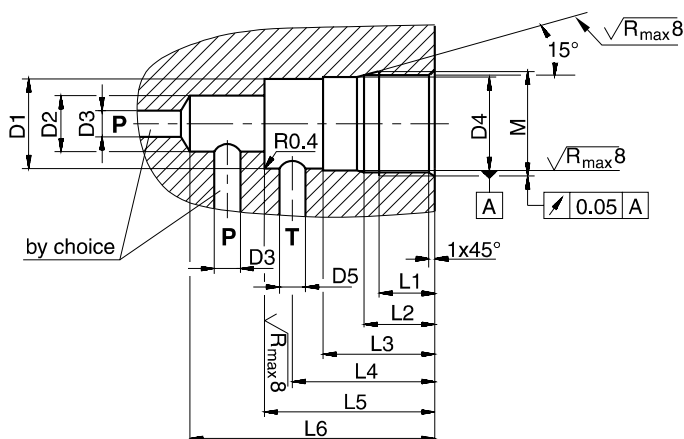

Tightening torque [Nm] ±5 %		
Pressure stages	NG06	NG10
064, 160	50	100
315	80	150

Size	M	D <sub>1</sub>	D <sub>2</sub>	D <sub>3</sub>	D <sub>4</sub>	D <sub>5</sub>	L <sub>1</sub>	L <sub>2</sub>	L <sub>3</sub>	L <sub>4</sub>	L <sub>5</sub>	L <sub>6</sub>
NG06	M28 x 1.5	Ø24.8	Ø15	Ø6.8	Ø25 <sup>H9</sup>	Ø6.8	15	19	30	35	45	65
NG10	M35 x 1.5	Ø31.8	Ø18.5	Ø10	Ø32 <sup>H9</sup>	Ø10	18	23	35	41 - 46	52	80

**Characteristics**

Direct operated pressure relief valves series R1E02 are seated type valves typically used for remote control of pilot operated pressure valves or compensators of variable pumps. In applications where the reliability and simplicity of a hydraulic remote control are preferred to an electro-hydraulic system the R1E02 series is an ideal solution.

**Features**

- Seated type valve
- Body variants:
  - front panel mounting
  - subplate mounting
- 3 pressure stages
- 3 adjustment modes:
  - hand knob
  - acorn nut with lead seal
  - cylinder lock

4



Front panel mounting



Subplate mounting

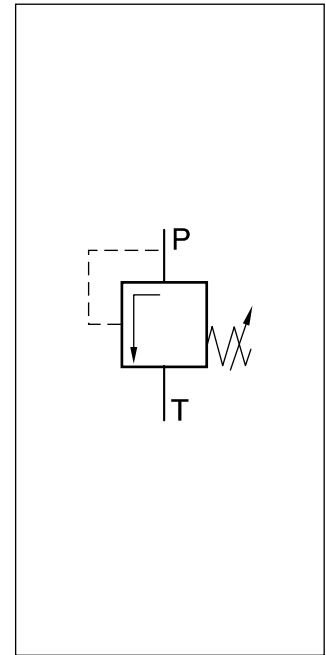

**R1E02, front panel mounting**

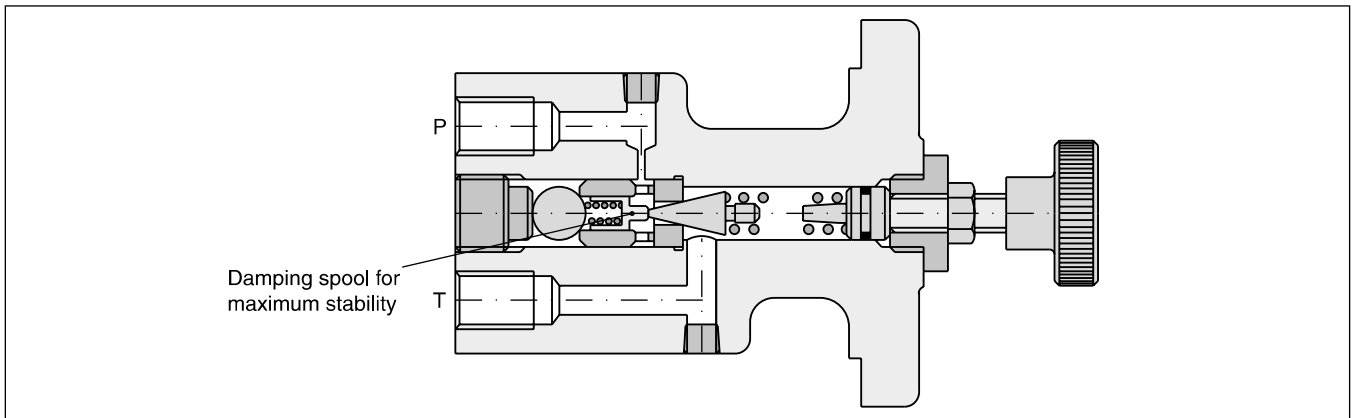

**Typical application as remote pilot valve**

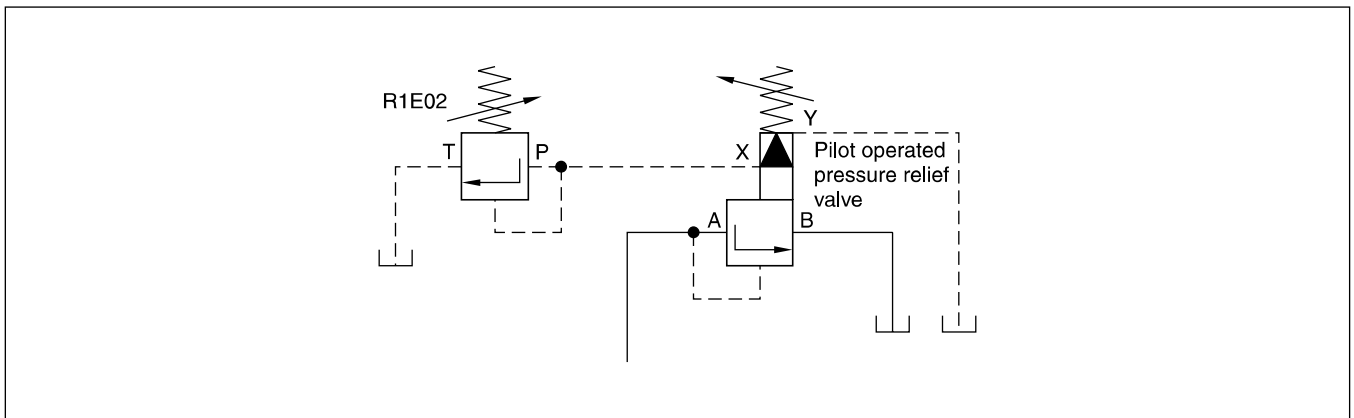

**Ordering code**

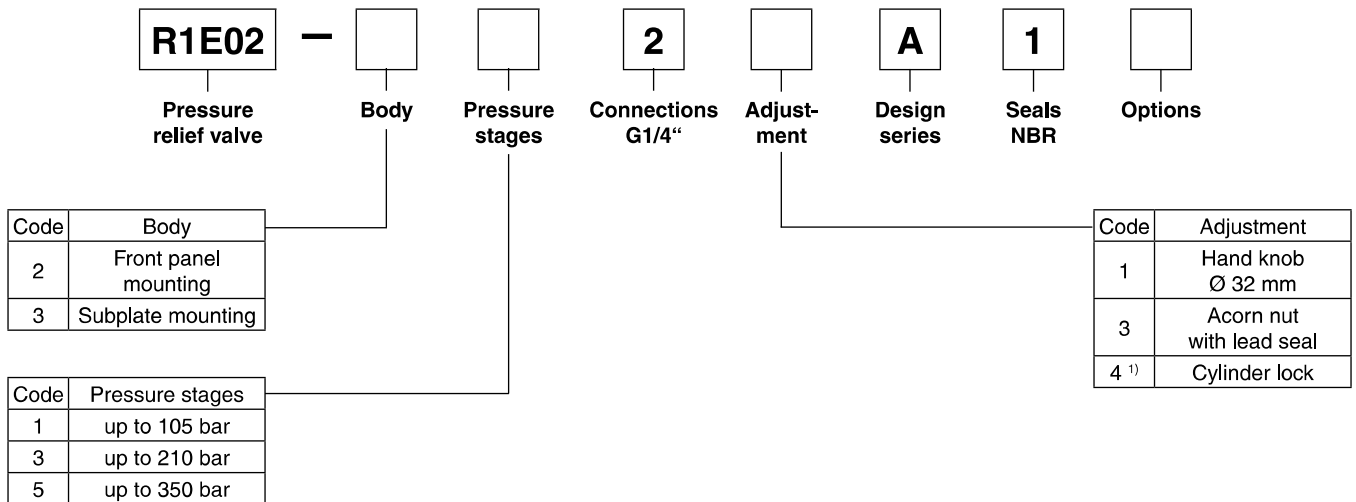

<sup>1)</sup> On bodies for subplate mounting use plate S16-64188 if necessary.

**Technical data**

General	
Design	Direct operated relief valve, seated type
Nominal size	1/4"
Body variants	Front panel mounting      Subplate mounting
Mounting position	unrestricted
Ambient temperature [°C]	-20...+60
MTTF <sub>D</sub> value [years]	150
Weight [kg]	2.1      1.0
Hydraulics	
Max. operating pressure [bar]	Port P 350, Port T depressurized
Pressure stages [bar]	105, 210, 350
Fluid temperature [°C]	-25...+70
Nominal flow [l/min]	3.8
Fluid	Hydraulic oil according to DIN 51524
Minimum setting pressure [bar]	7
Viscosity permitted [cSt] / [mm <sup>2</sup> /s]	20...400
Viscosity recommended [cSt] / [mm <sup>2</sup> /s]	30...80
Filtration	ISO 4406 (1999); 18/16/13

**Typical system pressure in relation to flow**

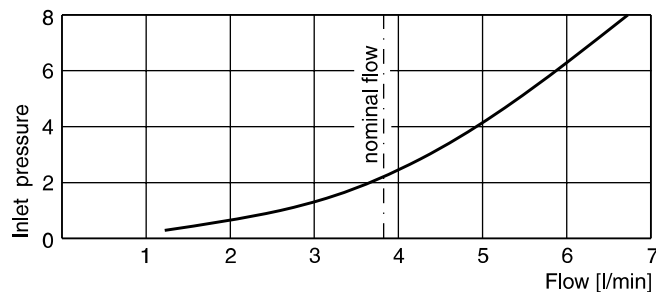

Measured with HLP46 at 50 °C.

**Dimensions**

**Front panel mounting**

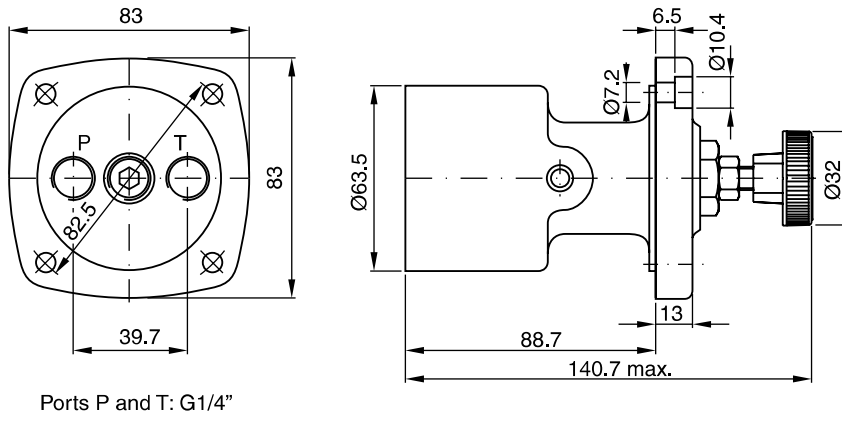

○ Kit
<b>S26-58466-0</b>

4

**Subplate mounting**

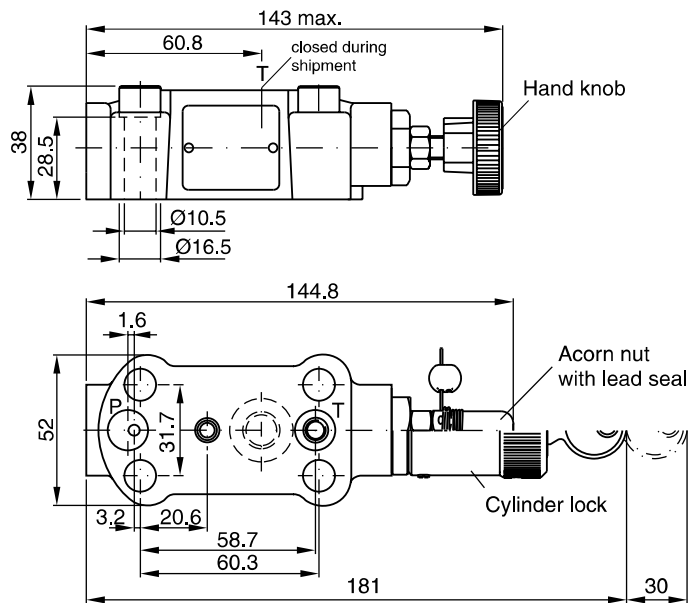

○ Kit
<b>S16-91963-0</b>

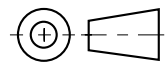

**Characteristics**

**Pilot Operated Pressure Relief Valves  
Series R4V / R6V**

Pilot operated pressure relief valves series R4V (DIN 24340 Form D) and R6V (DIN 24340 Form E) consist of a manually adjusted pilot stage and a seated type main stage.

A vent function with a solenoid operated directional valve is available for circulation at minimum pressure.

**Features**

- Pilot operated with manual adjustment
- 2 interfaces
  - R4V subplate ISO 6264 (DIN 24340 Form D) with VV01 vent valve
  - R6V subplate ISO 6264 (DIN 24340 Form E) with CETOP 03 vent valve
- 3 pressure stages
- 3 adjustment modes:
  - hand knob
  - acorn nut with lead seal
  - cylinder lock
- Remote control via port X

**Function:**

Series R4V/R6V

System pressure in port P is applied via the X gallery to the spring loaded cone in the pilot head. The pilot head controls the pressure in the Z area on top of the main cartridge which is additionally kept close by the main spring. If the pilot pressure exceeds the setting pressure the pilot cone opens and thus limits the pilot pressure.

When the system pressure exceeds the pilot pressure plus the spring force, the main cartridge opens to port T and limits the pressure in port P to the adjusted level.

Series R4V/R6V with vent function

Additionally to the relief function, a solenoid operated vent valve connects the Z area to tank. This allows oil circulation from P to T at minimum pressure drop. The vent valve can either be a standard CETOP 03 valve (R6V) or a sandwich unit (R4V). For both types the vent position can be either at the energized or de-energized solenoid.



R6V06



R6V06 with vent valve



R4V06 with vent valve

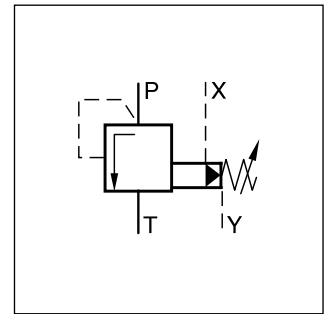

**R6V06 with vent valve**

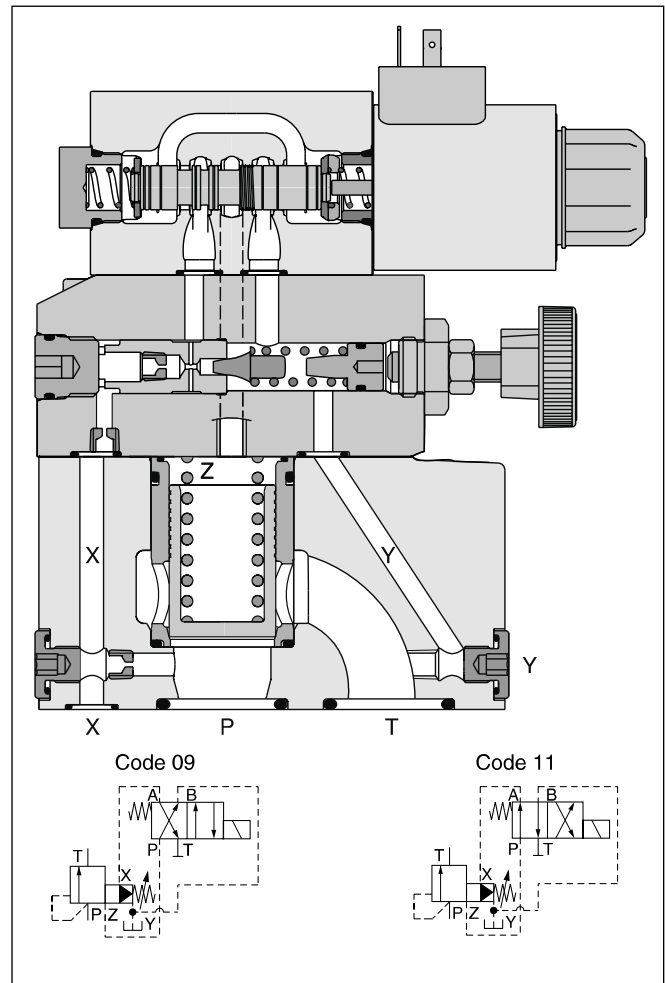

Ordering Code

4

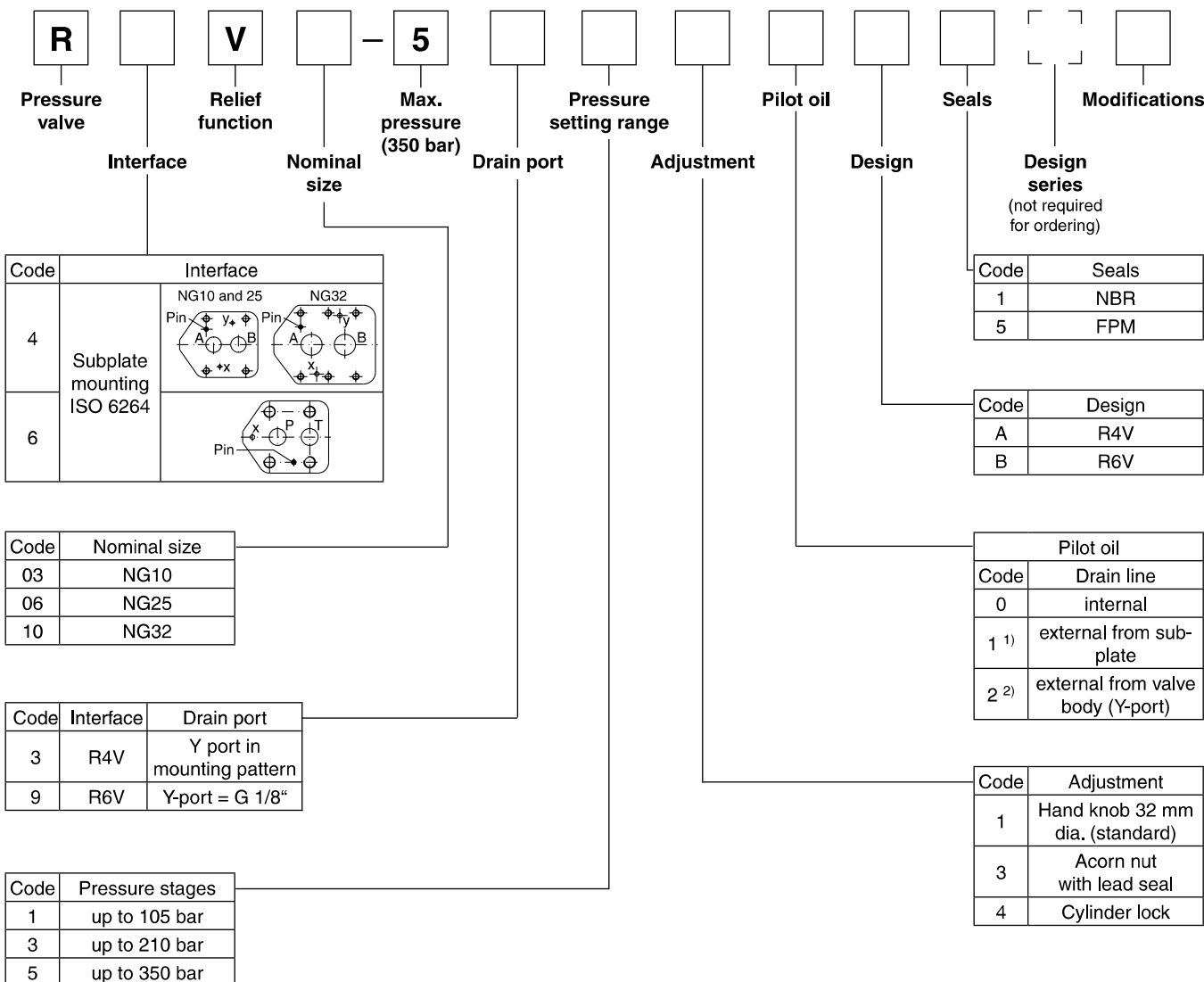

1) R4V only.  
2) R6V only.

Ordering Code

<b>R</b>		<b>V</b>		- <b>5</b>															
Pressure valve		Relief function		Max.pressure (350 bar)		Pressure setting range		Pilot oil		Solenoid voltage		Seals		Design series (not required for ordering)					
	Interface		Nominal size		Drain port		Adjustment		Vent valve function		Design								

Code	Interface	
4	Subplate mounting ISO 6264	
6		

Code	Nominal size
03	NG10
06	NG25
10	NG32

Code	Interface	Drain port
3	R4V	Y port in mounting pattern
9	R6V	Y-port = G 1/8"

Code	Pressure stages
1	up to 105 bar
3	up to 210 bar
5	up to 350 bar

Code	Adjustment
1	Hand knob (Standard)
3	Acorn nut with lead seal
4	Turning knob with key lock

Code	Modification
031 <sup>1)4)</sup>	Vent function with slow unloading
VFM <sup>2)4)</sup>	Vent function with slow unloading

Code	Seals
1	NBR
5	FPM

Code	Design
A	R4V
B	R6V

Code	Voltage
G0R	12 V =
G0Q	24 V =
GAR <sup>3)</sup>	98 V =
GAG <sup>3)</sup>	205 V =
W30	110 V / 50 Hz 120 V / 60 Hz
W31	230 V / 50 Hz 240 V / 60 Hz

Code	Vent valve
09	Solenoid not activ. unpress. circulation
11	Solenoid activated unpress. circulation

Pilot oil	
Code	Drain line
0	internal
1 <sup>1)</sup>	external from subplate
2 <sup>2)</sup>	external from valve body (Y-port)



1) R4V only.  
 2) R6V only.  
 3) To be used in combination with rectifier plugs at 120 VAC / 230 VAC power supply.  
 4) Vent valve function code 09 only.



**Technical Data**

**R4V/R6V**

General				
Nominal size		<b>NG10</b>	<b>NG25</b>	<b>NG32</b>
Interface	Subplate mounting acc. ISO 6264 (DIN 24340)			
Mounting position	Unrestricted, horizontal mounting preferred			
Ambient temperature	[°C]	-20...+60		
MTTF <sub>D</sub> value	[years]	75		
Weight	Series R6V [kg]	4.5	5.8	7.8
	Series R4V [kg]	2.7	4.5	6.0
Hydraulic				
Max. operating pressure	[bar]	Ports P (or A) and X up to 350, Port T (or B) and Y 30		
Pressure stages	[bar]	105, 210, 350		
Nominal flow	[l/min]	250	500	650
Fluid	Hydraulic oil according to DIN 51524			
Viscosity, permitted	[cSt] / [mm <sup>2</sup> /s]	20 ... 400		
recommended	[cSt] / [mm <sup>2</sup> /s]	30 ... 80		
Fluid temperature	[°C]	-20...+70 (NBR: -25...+70)		
Filtration	ISO 4406; 18/16/13			

4

**R4V/R6V with vent function**

General							
Nominal size		<b>NG10</b>	<b>NG25</b>	<b>NG32</b>			
Interface	Subplate mounting acc. ISO 6264 (DIN 24340)						
Mounting position	Unrestricted, horizontal mounting preferred						
Ambient temperature	[°C]	-20...+60					
MTTF <sub>D</sub> value	[years]	75					
Weight	Series R6V [kg]	5.9	7.2	9.2			
	Series R4V [kg]	4.4	6.2	7.7			
Hydraulic							
Max. operating pressure	[bar]	Ports P (or A) and X up to 350, port T (or B) and Y 30					
Pressure stages	[bar]	105, 210, 350					
Nominal flow	[l/min]	250	500	650			
Fluid	Hydraulic oil according to DIN 51524						
Viscosity, permitted	[cSt] / [mm <sup>2</sup> /s]	20 ... 400					
recommended	[cSt] / [mm <sup>2</sup> /s]	30 ... 80					
Fluid temperature	[°C]	-20...+70 (NBR: -25...+70)					
Filtration	ISO 4406; 18/16/13						
Electrical							
Duty ratio	[%]	100 ED; CAUTION: coil temperature up to 150 °C possible					
Protection class	IP65 in accordance with EN 60529 (with correctly mounted plug-in connector)						
	Code	G0R	G0Q	GAR	GAG	W30	W31
Supply voltage	[V]	12 V =	24 V =	98 V =	205 V =	110 V/50 Hz 120 V/60 Hz	230 V/50 Hz 240 V/60 Hz
Tolerance supply voltage	[%]	±10	±10	±10	±10	±5	±5
Current consumption	hold [A]	2.72	1.29	0.33	0.13	0.6 / 0.55	0.3 / 0.27
	in rush [A]	2.72	1.29	0.33	0.13	2.5 / 2.4	1.25 / 1.2
Power consumption	hold [W]	32.7	31	31.9	28.2	70 / 70 VA	70 / 70 VA
	in rush [W]	32.7	31	31.9	28.2	280 / 290 VA	280 / 290 VA
Solenoid connection	Connector as per EN175301-803, solenoid identification as per ISO 9461						
Wiring min.	[mm <sup>2</sup> ]	3 x 1.5 recommended					
Wiring length max.	[m]	50 recommended					





**p/Q performance curves <sup>1)</sup>**

**NG10**

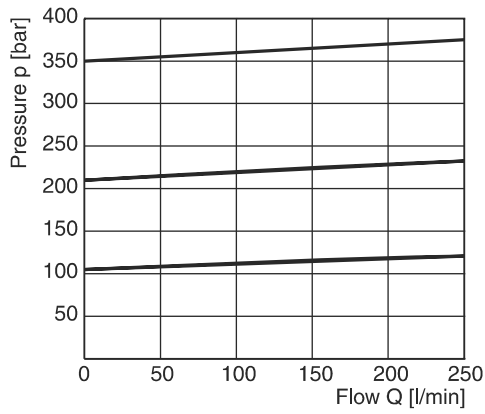

**NG25**

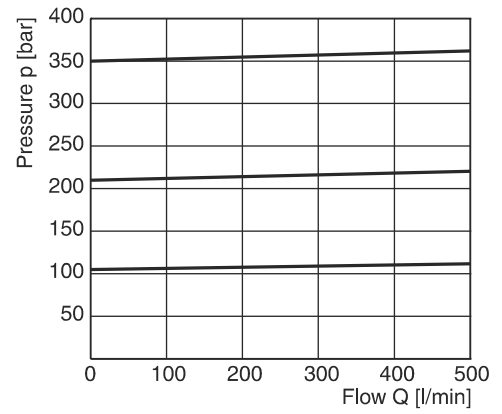

**NG32**

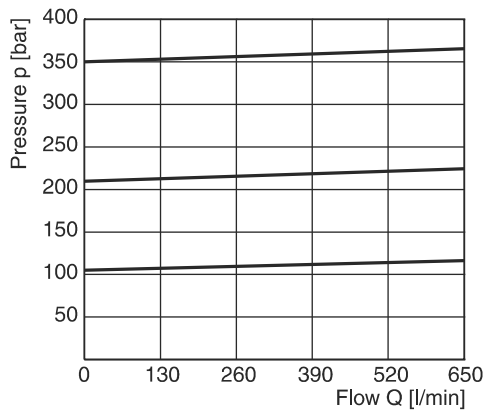

**Minimum pressure curve**

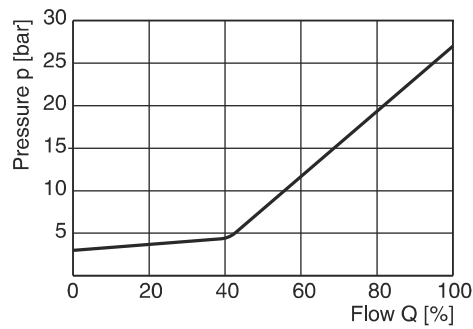

All characteristic curves measured with HLP46 at 50 °C.

<sup>1)</sup> The performance curves are measured with external drain.  
 For internal drain the tank pressure has to be added to curve.

Dimensions

R6V

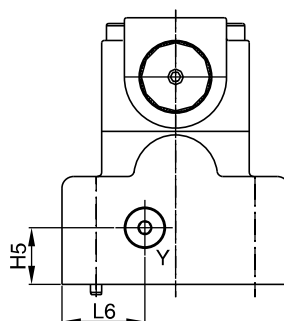
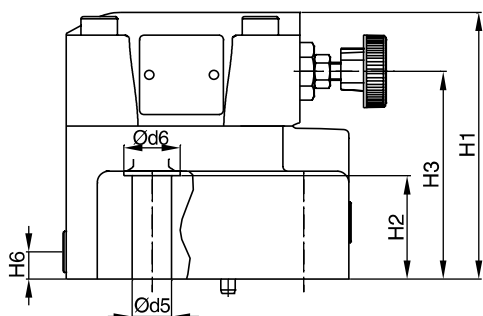
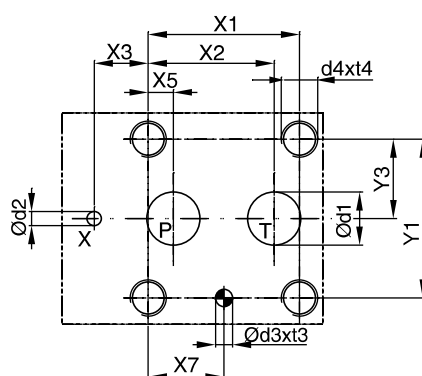
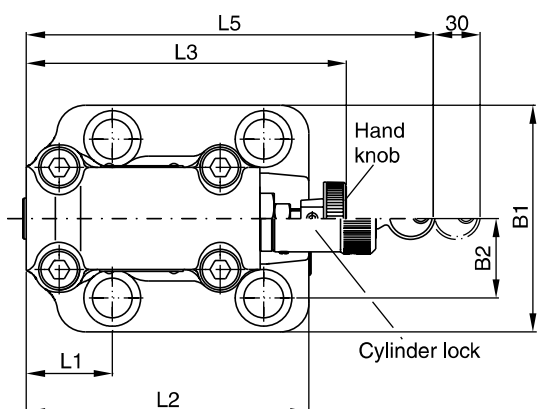

Y: external drain port G 1/8"

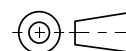

4

NG	ISO-code	x1	x2	x3	x4	x5	x6	x7	y1	y2	y3	y4	y5	y6
10	6264-06-09-*-97	53.8	47.5	0	-	22.1	-	22.1	53.8	-	26.9	-	-	-
25	6264-08-13-*-97	66.7	55.6	23.8	-	11.1	-	33.4	70	-	35	-	-	-
32	6264-10-17-*-97	88.9	76.2	31.8	-	12.7	-	44.5	82.6	-	41.3	-	-	-

Tolerance at X and Y pin holes and screw holes ±0.1, at port holes ±0.2.

NG	ISO-code	B1	B2	H1	H2	H3	H4	H5	H6	L1	L2	L3	L4	L5	L6
10	6264-06-09-*-97	80	26.9	114	27	88	-	20.5	25	52	117	141	-	180	29.5
25	6264-08-13-*-97	100	35	117.5	46.5	91.5	-	25	12	37.9	124.5	141	-	180	36.5
32	6264-10-17-*-97	120	41.3	124.5	51.3	98.5	-	26.5	13.5	44.3	153	141	-	180	46.5

NG	ISO-code	d1max	d2max	d3	t3	d4	t4	d5	d6	Subplate <sup>1)</sup>
10	6264-06-09-*-97	14.7	4.8	7.5	10	M12	20	13.5	20	SPP 3R6B 910
25	6264-08-13-*-97	23.4	6.3	7.5	10	M16	27	17.5	25	SPP 6R10B 910
32	6264-10-17-*-97	32	6.3	7.5	10	M18	28	20	30	SPP 10R12B 910

NG	Kit	Kit	Kit	Kit		Surface finish
				NBR	FPM	
10	BK494	4x M12x45 ISO 4762-12.9	108 Nm ±15 %	S26-98589-0	S26-98589-5	
25	BK366	4x M16x70 ISO 4762-12.9	264 Nm ±15 %	S26-96396-0	S26-96396-5	
32	BK507	4x M18x75 ISO 4762-12.9	398 Nm ±15 %	S26-96392-0	S26-96392-5	

<sup>1)</sup> Details see chapter 12, series SPP.

**R6V with vent function**

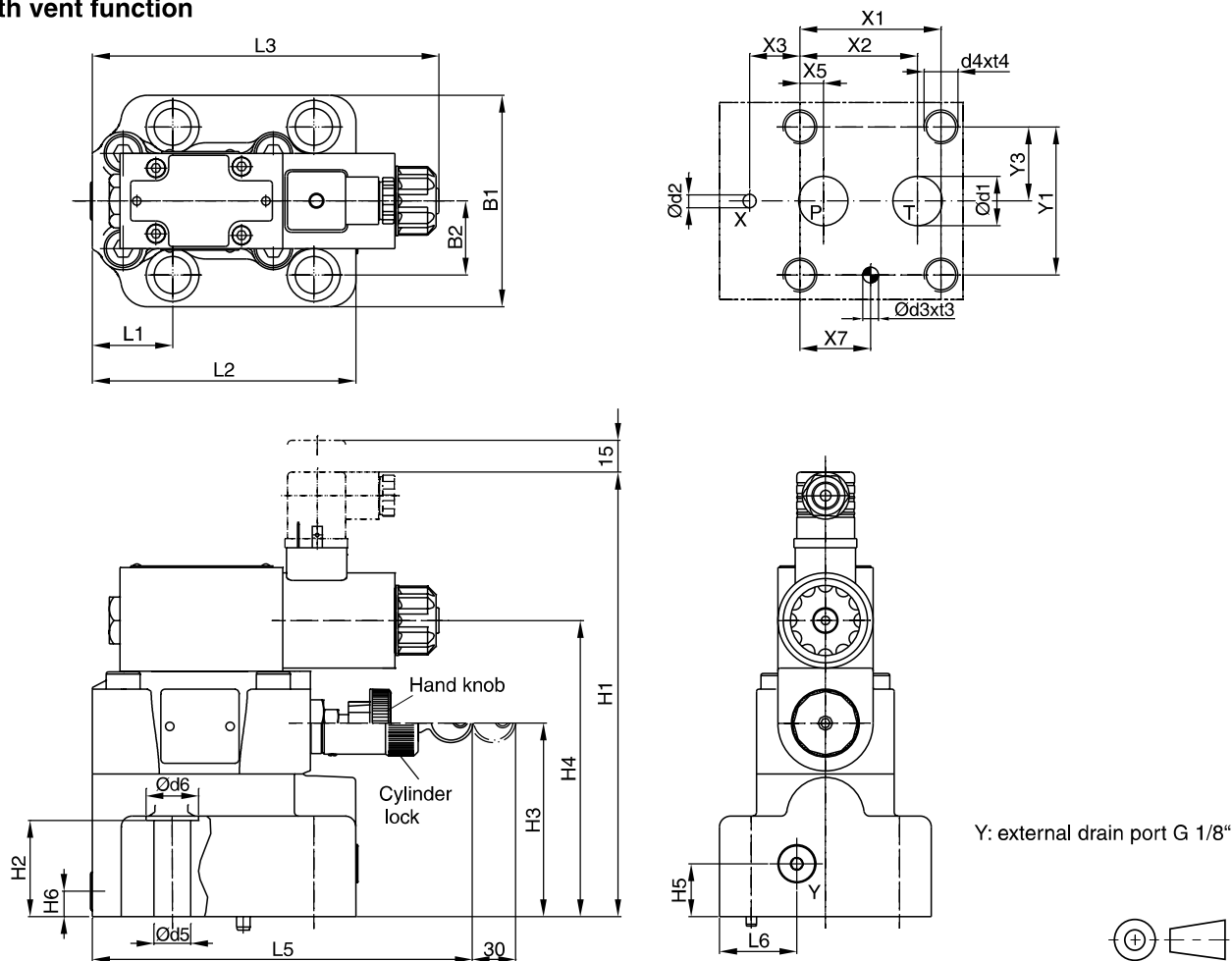

**4**

NG	ISO-code	x1	x2	x3	x4	x5	x6	x7	y1	y2	y3	y4	y5	y6
10	6264-06-09-*-97	53.8	47.5	0	-	22.1	-	22.1	53.8	-	26.9	-	-	-
25	6264-08-13-*-97	66.7	55.6	23.8	-	11.1	-	33.4	70	-	35	-	-	-
32	6264-10-17-*-97	88.9	76.2	31.8	-	12.7	-	44.5	82.6	-	41.3	-	-	-

Tolerance at X and Y pin holes and screw holes ±0.1, at port holes ±0.2.

NG	ISO-code	B1	B2	H1	H2	H3	H4	H5	H6	L1	L2	L3	L4	L5	L6
10	6264-06-09-*-97	80	26.9	203.4	27	88	136.3	25	12	52	117	163.8		180	36.5
25	6264-08-13-*-97	100	35	206.9	46.5	91.5	139.8	25	12	37.9	124.5	163.8	-	180	36.5
32	6264-10-17-*-97	120	41.3	213.9	51.3	98.5	146.8	25	12	44.3	153	163.8		180	36.5

NG	ISO-code	d1max	d2max	d3	t3	d4	t4	d5	d6	Subplate <sup>1)</sup>
10	6264-06-09-*-97	14.7	4.8	7.5	10	M12	20	13.5	20	SPP 3R6B 910
25	6264-08-13-*-97	23.4	6.3	7.5	10	M16	27	17.5	25	SPP 6R10B 910
32	6264-10-17-*-97	32	6.3	7.5	10	M18	28	20	30	SPP 10R12B 910

NG	Kit	Kit	Kit	Kit		Surface finish
				NBR	FPM	
10	BK494	4x M12x45 ISO 4762-12.9	108 Nm ±15 %	S26-98589-0	S26-98589-5	
25	BK366	4x M16x70 ISO 4762-12.9	264 Nm ±15 %	S26-96396-0	S26-96396-5	
32	BK507	4x M18x75 ISO 4762-12.9	398 Nm ±15 %	S26-96392-0	S26-96392-5	

<sup>1)</sup> Details see chapter 12, series SPP.

Dimensions

R4V

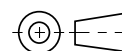
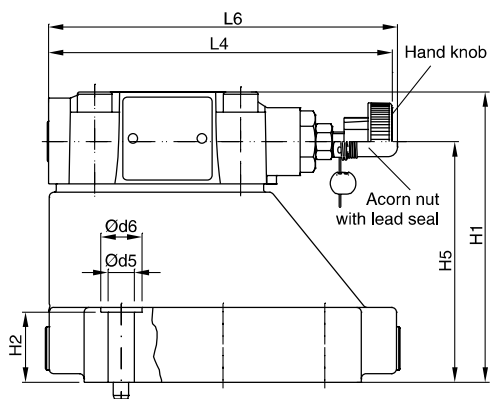
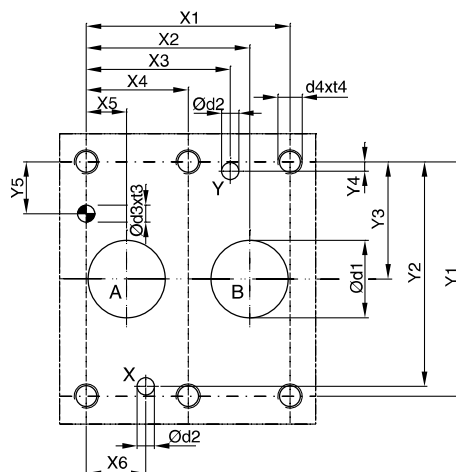
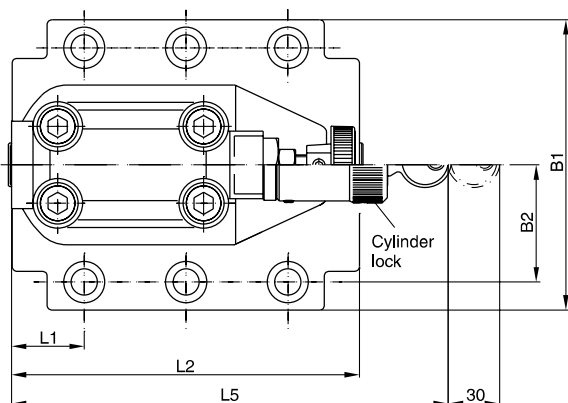

4

NG	ISO-code	x1	x2	x3	x4	x5	x6	x7	y1	y2	y3	y4	y5	y6
10	6264-06-07-* <sup>-97</sup>	42.9	35.8	21.5	–	7.2	21.5	0	66.7	58.8	33.4	7.9	14.3	–
25	6264-08-11-* <sup>-97</sup>	60.3	49.2	39.7	–	11.1	20.6	0	79.4	73	39.7	6.4	15.9	–
32	6264-10-15-* <sup>-97</sup>	84.2	67.5	59.5	42.1	16.7	24.6	0	96.8	92.8	48.4	3.8	21.4	–

Tolerance at X and Y pin holes and screw holes ±0.1, at port holes ±0.2.

NG	ISO-code	B1	B2	H1	H2	H3	H4	H5	H6	L1	L2	L3	L4	L5	L6
10	6264-06-07-* <sup>-97</sup>	87.3	33.35	83	21	–	–	62.5	–	25	90.8	–	143	181	144.8
25	6264-08-11-* <sup>-97</sup>	105	39.7	107.5	29	–	–	87	–	30.9	123	–	143	181	144.8
32	6264-10-15-* <sup>-97</sup>	120	48.4	120	30	–	–	99.5	–	29.8	143.5	–	143	181	144.8

NG	ISO-code	d1max	d2max	d3	t3	d4	t4	d5	d6	Subplate <sup>1)</sup>
10	6264-06-07-* <sup>-97</sup>	15	7	7.1	8	M10	16	10.8	17	SPP 3M6B 910
25	6264-08-11-* <sup>-97</sup>	23.4	7.1	7.1	8	M10	18	10.8	17	SPP 6M8B 910
32	6264-10-15-* <sup>-97</sup>	32	7.1	7.1	8	M10	20	10.8	17	SPP 10M12B 910

NG	Kit	Kit	Kit	Kit		Surface finish
				NBR	FPM	
10	BK505	4x M10x35 ISO 4762-12.9	63 Nm ±15 %	S26-58507-0	S26-58507-5	
25	BK485	4x M10x45 ISO 4762-12.9	63 Nm ±15 %	S26-58475-0	S26-58475-5	
32	BK506	6x M10x45 ISO 4762-12.9	63 Nm ±15 %	S26-58508-0	S26-58508-5	

<sup>1)</sup> Details see chapter 12, series SPP.

**R4V with vent function**

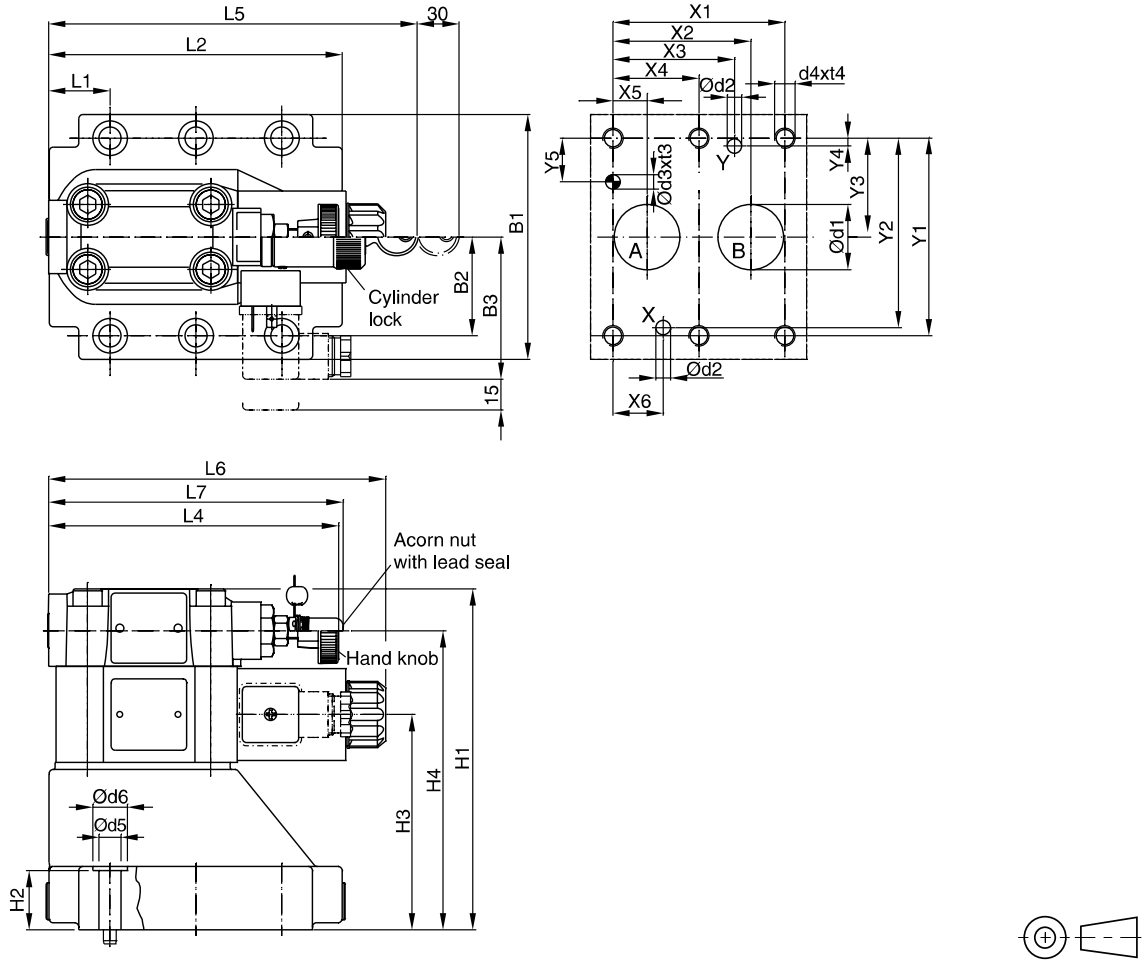

**4**

NG	ISO-code	x1	x2	x3	x4	x5	x6	x7	y1	y2	y3	y4	y5	y6
10	6264-06-07-*-97	42.9	35.8	21.5	–	7.2	21.5	0	66.7	58.8	33.4	7.9	14.3	–
25	6264-08-11-*-97	60.3	49.2	39.7	–	11.1	20.6	0	79.4	73	39.7	6.4	15.9	–
32	6264-10-15-*-97	84.2	67.5	59.5	42.1	16.7	24.6	0	96.8	92.8	48.4	3.8	21.4	–

Tolerance at X and Y pin holes and screw holes ±0.1, at port holes ±0.2.

NG	ISO-code	B1	B2	B3	H1	H2	H3	H4	H6	L1	L2	L3	L4	L5	L6	L7
10	6264-06-07-*-97	87.3	33.35	70	130	21	68.5	109.5	–	25	90.8	–	143	181	165.6	144.8
25	6264-08-11-*-97	105	39.7	70	154.5	29	93	134	–	30.9	123	–	143	181	165.6	144.8
32	6264-10-15-*-97	120	48.4	70	167	30	105.5	146.5	–	29.8	143.5	–	143	181	165.6	144.8

NG	ISO-code	d1max	d2max	d3	t3	d4	t4	d5	d6	Subplate <sup>1)</sup>
10	6264-06-07-*-97	15	7	7.1	8	M10	16	10.8	17	SPP 3M6B 910
25	6264-08-11-*-97	23.4	7.1	7.1	8	M10	18	10.8	17	SPP 6M8B 910
32	6264-10-15-*-97	32	7.1	7.1	8	M10	20	10.8	17	SPP 10M12B 910

NG	Kit	Kit	Kit	Kit		Surface finish
				NBR	FPM	
10	BK505	4x M10x35 ISO 4762-12.9	63 Nm ±15 %	S26-58507-0 <sup>2)</sup>	S26-58507-5 <sup>2)</sup>	
25	BK485	4x M10x45 ISO 4762-12.9	63 Nm ±15 %	S26-58475-0 <sup>2)</sup>	S26-58475-5 <sup>2)</sup>	
32	BK506	6x M10x45 ISO 4762-12.9	63 Nm ±15 %	S26-58508-0 <sup>2)</sup>	S26-58508-5 <sup>2)</sup>	
VV01, AC solenoid				S26-35237-0	S26-35237-5	
VV01, DC solenoid				S56-40609-0	S56-40609-5	

<sup>1)</sup> Details see chapter 12, series SPP.

<sup>2)</sup> Please combine seal kit of one size with seal kit of VV01 solenoid for complete seal kit.

**Characteristics**

Pilot operated pressure relief valves series R4V (TÜV) (DIN 24340 Form D) and R6V (TÜV) (DIN 24340 Form E) include a certification according to directive 2014/68/EU for the usage for safety-related applications.

The valve is set and sealed by the German technical inspection association TÜV. The valve delivery includes the TÜV certificate of conformity.

For series R6V a vent function with a solenoid operated directional valve is available for circulation at minimum pressure.

**Features**

- TÜV certificate
- Pilot operated with manual adjustment
- 2 interfaces:
  - R4V subplate ISO 6264 (DIN 24340 Form D)
  - R6V subplate ISO 6264 (DIN 24340 Form E) with CETOP 03 vent valve
- Adjustment leaved (code W)
- Adjustment leaved to maximum pressure, lower pressure possible (code V)



R6V06



R6V06 with vent valve



R4V06



**Name plate data**

Example R4V06

- 415 mm<sup>2</sup> : minimum opening width
- L220 l/min : max. flow
- 70 bar : set pressure (compare p/Q curves)
- 7,3 mm : cartridge stroke
- 10 % : permitted pressure increase of the flow range

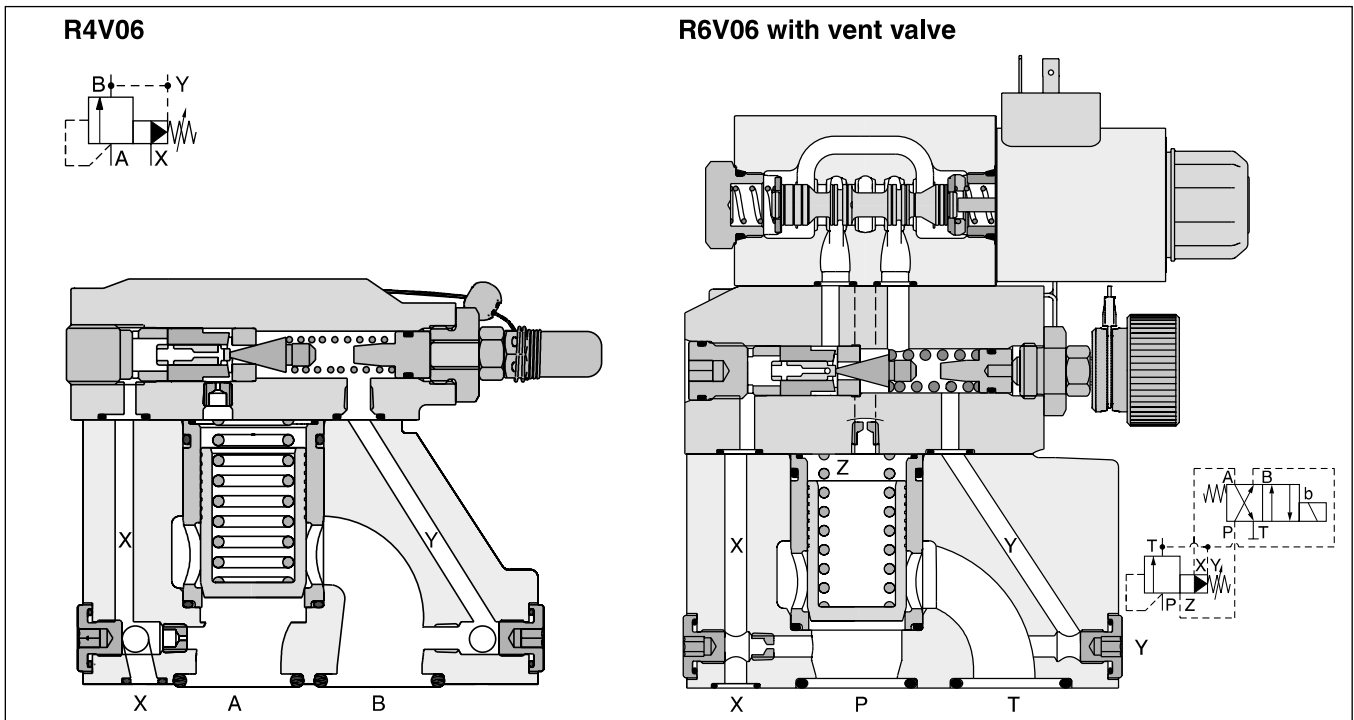

**R4V / R6V**

<b>R</b>		<b>V</b>		<b>-</b>	<b>5</b>		<b>5</b>		<b>0</b>			
Pressure valve		Relief function			Max. pressure (350 bar)		Pressure setting range 350 bar max.		Pilot oil internal		Seals	
	Interface		Nominal size		Body		Adjustment leaded (TÜV)		Design series		Pressure stage	

Code	Interface	
4	Subplate mounting ISO 6264	NG10 and 25 
6		NG32 

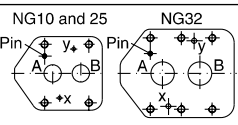
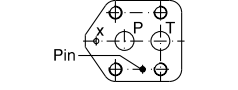
Code	Nominal size
03	NG10 <sup>1)</sup>
06	NG25
10	NG32

Code	Body
3	R4V
9	R6V

Code	Design
A	R4V, R6V with adjustment code W
B	R6V with adjustment code V

Code	Adjustment
V	Hand knob leaded (lower pressure adjustment possible)
W	Acorn nut leaded

Code	Pressure stage <sup>2)</sup>
P10	100 bar
P20	200 bar
P30	300 bar
P35	350 bar

Code	Seals
1	NBR
5	FPM

4

**R6V with vent valve**

<b>R</b>	<b>6</b>	<b>V</b>		<b>-</b>	<b>5</b>	<b>9</b>	<b>5</b>	<b>V</b>	<b>0</b>	<b>09</b>		<b>B</b>		
Pressure valve		Relief function			Max. pressure (350 bar)	Body Y-port = G 1/8"	Pressure setting range 350 bar max.	Adjustment leaded (TÜV) Hand knob leaded (lower pressure adjustment possible)	Pilot oil internal	Vent valve function solenoid not active, unpressurized circulation	Solenoid voltage	Seals	Design series	Pressure stage
	Interface		Nominal size											

Code	Interface	
6	Subplate mounting ISO 6264	

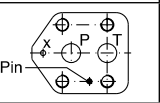
Code	Nominal size
06	NG25
10	NG32

Code	Pressure stage <sup>2)</sup>
P10	100 bar
P20	200 bar
P30	300 bar
P35	350 bar

Code	Seals
1	NBR
5	FPM

Code	Voltage
G0R	12 V =
G0Q	24 V =

<sup>1)</sup> Not for R6V.

<sup>2)</sup> Further pressure stages on request (in 10 bar steps).

**Technical Data / Characteristic Curves**

**R4V / R6V**

General			NG10	NG25	NG32
Nominal size					
Interface			Subplate mounting acc. ISO 6264		
Mounting position			Unrestricted, horizontal mounting preferred		
Ambient temperature	[°C]		-20...+60		
MTTF <sub>D</sub> value	[years]		75		
Weight					
	Series R6V	[kg]	—	5.8	7.8
	Series R4V	[kg]	2.7	4.5	6.0
Hydraulic					
Max. operating pressure	[bar]		Ports P (or A) up to 350, Port T (or B) and Y 30		
Pressure stages	[bar]		350 (pressure setting see ordering code)		
Max. flow					
	R6V	[l/min]	—	500	500
	R4V	[l/min]	110	450	500
Fluid			Hydraulic oil according to DIN 51524		
Fluid temperature	[°C]		-10...+70		
Viscosity, permitted	[cSt] / [mm <sup>2</sup> /s]		20 ... 400		
recommended	[cSt] / [mm <sup>2</sup> /s]		30 ... 80		
Filtration			ISO 4406; 18/16/13		

**R6V with vent function**

General			NG25	NG32
Nominal size				
Interface			Subplate mounting acc. ISO 6264	
Mounting position			Unrestricted, horizontal mounting preferred	
Ambient temperature	[°C]		-20...+60	
MTTF <sub>D</sub> value	[years]		75	
Weight	[kg]		7.2	9.2
Hydraulic				
Max. operating pressure	[bar]		Ports P up to 350, port T and Y 30	
Pressure stages	[bar]		350 (pressure setting see ordering code)	
Max. flow	[l/min]		500	
Fluid			Hydraulic oil according to DIN 51524	
Viscosity, permitted	[cSt] / [mm <sup>2</sup> /s]		20 ... 400	
recommended	[cSt] / [mm <sup>2</sup> /s]		30 ... 80	
Fluid temperature	[°C]		-10 ... +70	
Filtration			ISO 4406; 18/16/13	
Electrical				
Duty ratio	[%]		100 ED; CAUTION: coil temperature up to 150 °C possible	
Protection class			IP65 in accordance with EN 60529 (with correctly mounted plug-in connector)	
	Code		G0R	G0Q
Supply voltage	[V]		12 V =	24 V =
Tolerance supply voltage	[%]		±10	±10
Power consumption				
	hold	[W]	32.7	31
	in rush	[W]	32.7	31
Solenoid connection			Connector as per EN 175301-803	
Wiring min.	[mm <sup>2</sup> ]		3 x 1.5 recommended	
Wiring length max.	[m]		50 recommended	

**R4V/ R6V minimum pressure curve <sup>1)</sup>**

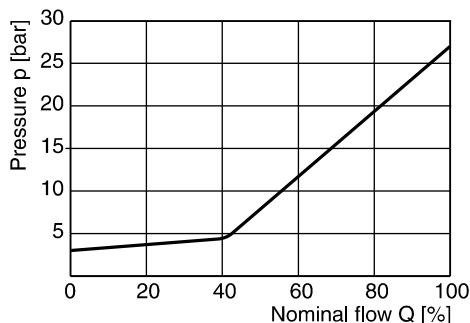

All characteristic curves measured with HLP46 at 50 °C.

<sup>1)</sup> The performance curves are measured with external drain.  
For internal drain the tank pressure has to be added to curve.





**p/Q performance curves <sup>1)</sup>**

**R4V03**

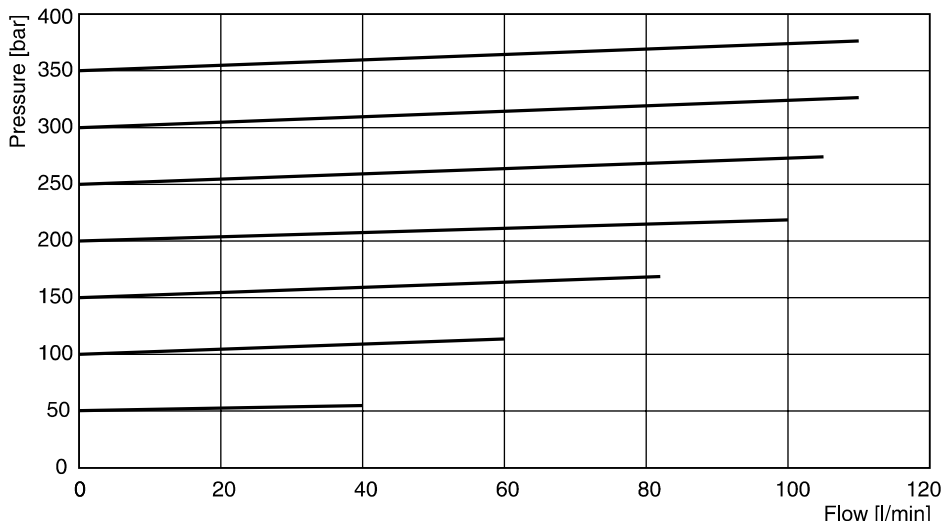

**R4V03 nameplate data**

Pressure stage	Q <sub>max</sub>	min. opening width	Cartridge stroke	Permitted pressure increase
50 - 70 bar	40 l/min	154 mm <sup>2</sup>	4.4 mm	10 %
80 - 120 bar	60 l/min	154 mm <sup>2</sup>	4.4 mm	10 %
130 - 170 bar	82 l/min	154 mm <sup>2</sup>	4.4 mm	10 %
180 - 200 bar	100 l/min	154 mm <sup>2</sup>	4.4 mm	10 %
210 - 250 bar	105 l/min	154 mm <sup>2</sup>	4.4 mm	10 %
260 - 300 bar	110 l/min	154 mm <sup>2</sup>	4.4 mm	10 %
310 - 350 bar	110 l/min	154 mm <sup>2</sup>	4.4 mm	10 %

**R4V06**

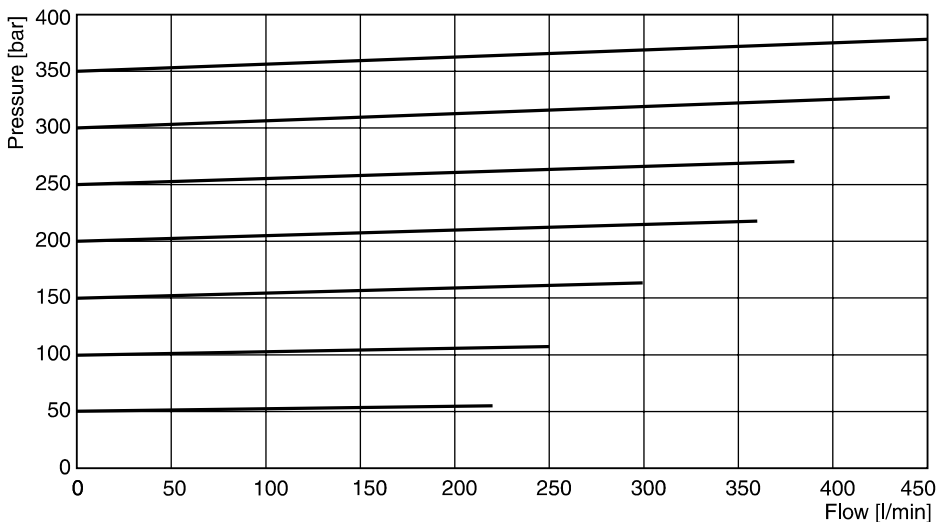

**R4V06 nameplate data**

Pressure stage	Q <sub>max</sub>	min. opening width	Cartridge stroke	Permitted pressure increase
50 - 70 bar	220 l/min	415 mm <sup>2</sup>	7.3 mm	10 %
80 - 120 bar	250 l/min	415 mm <sup>2</sup>	7.3 mm	10 %
130 - 170 bar	300 l/min	415 mm <sup>2</sup>	7.3 mm	10 %
180 - 200 bar	360 l/min	415 mm <sup>2</sup>	7.3 mm	10 %
210 - 250 bar	380 l/min	415 mm <sup>2</sup>	7.3 mm	10 %
260 - 300 bar	430 l/min	415 mm <sup>2</sup>	7.3 mm	10 %
310 - 350 bar	450 l/min	415 mm <sup>2</sup>	7.3 mm	10 %

<sup>1)</sup> The performance curves are measured with external drain.  
 For internal drain the tank pressure has to be added to curve.

**p/Q performance curves <sup>1)</sup>**

**R4V10**

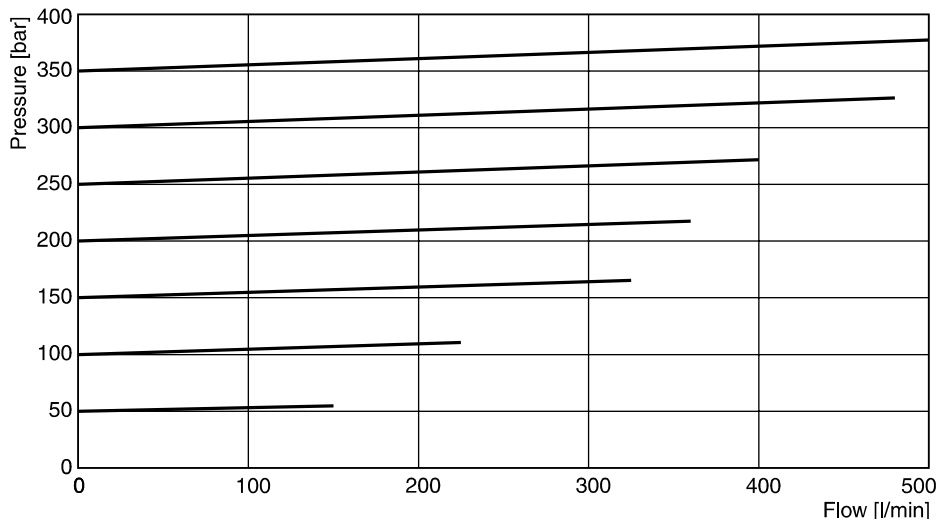

**R4V10 nameplate data**

Pressure stage	Q <sub>max</sub>	min. opening width	Cartridge stroke	Permitted pressure increase
50 - 70 bar	150 l/min	607 mm <sup>2</sup>	7.3 mm	10 %
80 - 120 bar	225 l/min	607 mm <sup>2</sup>	7.3 mm	10 %
130 - 170 bar	325 l/min	607 mm <sup>2</sup>	7.3 mm	10 %
180 - 200 bar	360 l/min	607 mm <sup>2</sup>	7.3 mm	10 %
210 - 250 bar	400 l/min	607 mm <sup>2</sup>	7.3 mm	10 %
260 - 300 bar	480 l/min	607 mm <sup>2</sup>	7.3 mm	10 %
310 - 350 bar	500 l/min	607 mm <sup>2</sup>	7.3 mm	10 %

**R6V06**

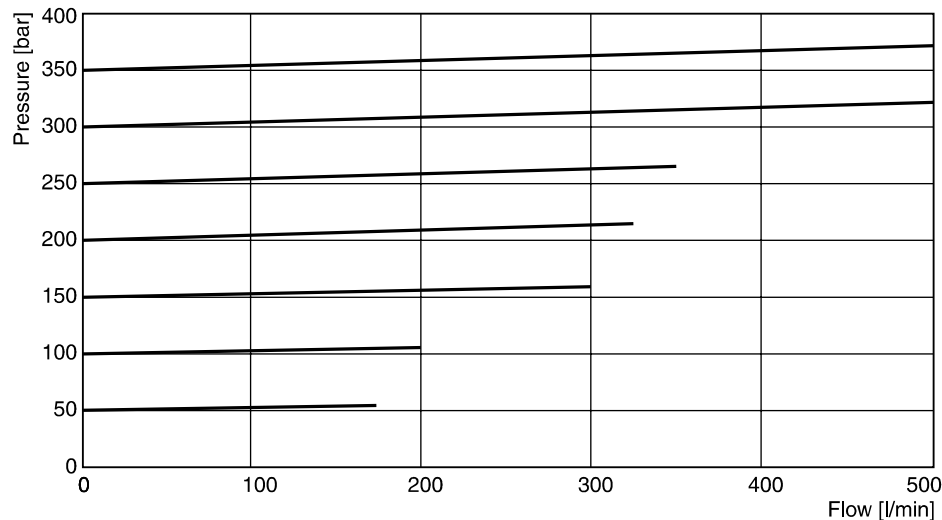

**R6V06 nameplate data**

Pressure stage	Q <sub>max</sub>	min. opening width	Cartridge stroke	Permitted pressure increase
50 - 70 bar	170 l/min	415 mm <sup>2</sup>	7.3 mm	10 %
80 - 120 bar	200 l/min	415 mm <sup>2</sup>	7.3 mm	10 %
130 - 170 bar	300 l/min	415 mm <sup>2</sup>	7.3 mm	10 %
180 - 200 bar	325 l/min	415 mm <sup>2</sup>	7.3 mm	10 %
210 - 250 bar	350 l/min	415 mm <sup>2</sup>	7.3 mm	10 %
260 - 300 bar	500 l/min	415 mm <sup>2</sup>	7.3 mm	10 %
310 - 350 bar	500 l/min	415 mm <sup>2</sup>	7.3 mm	10 %

<sup>1)</sup> The performance curves are measured with external drain.  
 For internal drain the tank pressure has to be added to curve.

**p/Q performance curves <sup>1)</sup>**

**R6V10**

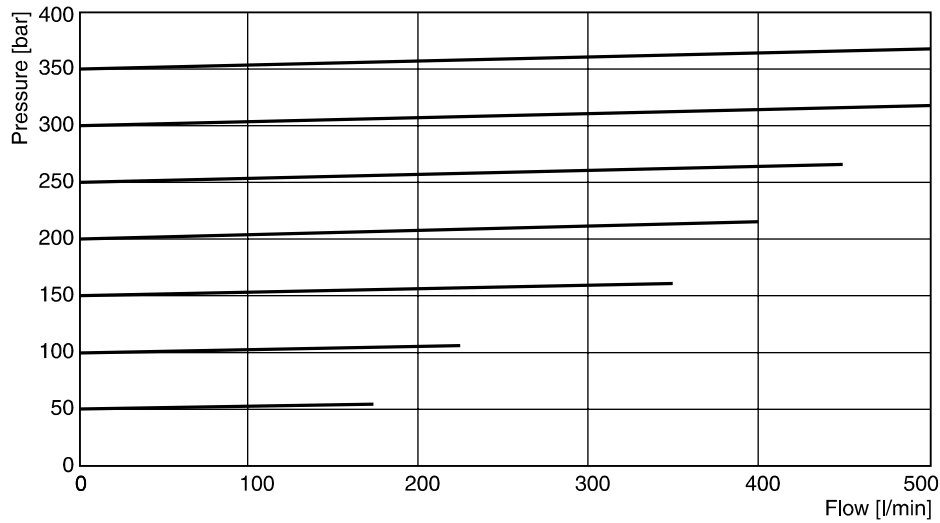

**R6V10 nameplate data**

Pressure stage	Q <sub>max</sub>	min. opening width	Cartridge stroke	Permitted pressure increase
50 - 70 bar	170 l/min	607 mm <sup>2</sup>	7.3 mm	10 %
80 - 120 bar	225 l/min	607 mm <sup>2</sup>	7.3 mm	10 %
130 - 170 bar	350 l/min	607 mm <sup>2</sup>	7.3 mm	10 %
180 - 200 bar	400 l/min	607 mm <sup>2</sup>	7.3 mm	10 %
210 - 250 bar	450 l/min	607 mm <sup>2</sup>	7.3 mm	10 %
260 - 300 bar	500 l/min	607 mm <sup>2</sup>	7.3 mm	10 %
310 - 350 bar	500 l/min	607 mm <sup>2</sup>	7.3 mm	10 %

<sup>1)</sup> The performance curves are measured with external drain.  
 For internal drain the tank pressure has to be added to curve.

**R6V**

4

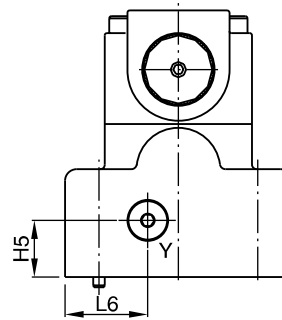
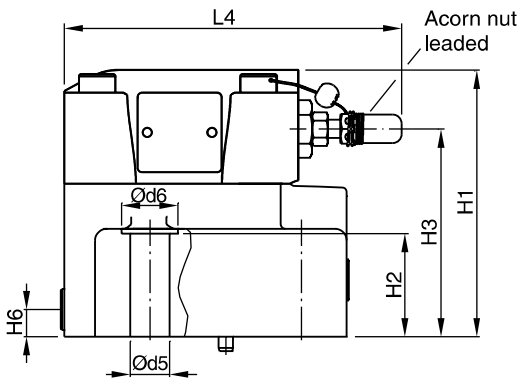
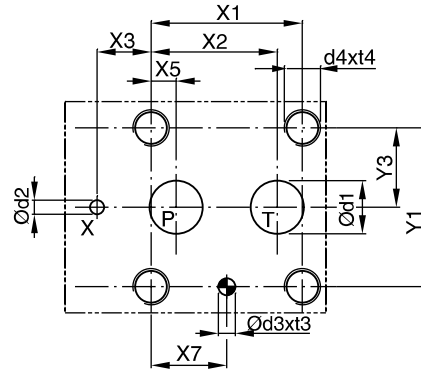
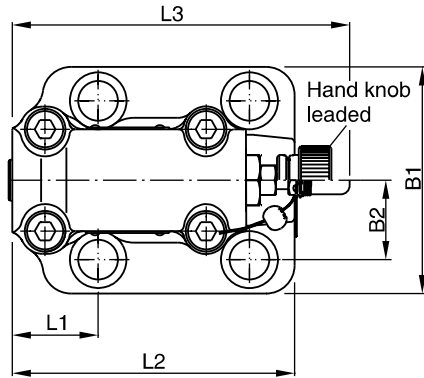

Y: external drain port G 1/8"

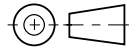





NG	ISO-code	x1	x2	x3	x4	x5	x6	x7	y1	y2	y3	y4	y5	y6
25	6264-08-13-*-97	66.7	55.6	23.8	-	11.1	-	33.4	70	-	35	-	-	-
32	6264-10-17-*-97	88.9	76.2	31.8	-	12.7	-	44.5	82.6	-	41.3	-	-	-

Tolerance at X and Y pin holes and screw holes ±0.1, at port holes ±0.2.

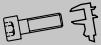
NG	ISO-code	B1	B2	H1	H2	H3	H4	H5	H6	L1	L2	L3	L4	L6
25	6264-08-13-*-97	100	35	117.5	46.5	91.5	-	25	12	37.9	124.5	141	144.8	36.5
32	6264-10-17-*-97	120	41.3	124.5	51.3	98.5	-	26.5	13.5	44.3	153	141	144.8	46.5

NG	ISO-code	d1max	d2max	d3	t3	d4	t4	d5	d6	Subplate <sup>1)</sup>
25	6264-08-13-*-97	23.4	6.3	7.5	10	M16	27	17.5	25	SPP 6R10B 910
32	6264-10-17-*-97	32	6.3	7.5	10	M18	28	20	30	SPP 10R12B 910

NG	Bolt kit			Kit		Surface finish
				NBR	FPM	
25	BK366	4x M16x70 ISO 4762-12.9	264 Nm ±15 %	S26-96396-0	S26-96396-5	$\sqrt{R_{max}6.3}$ 
32	BK507	4x M18x75 ISO 4762-12.9	398 Nm ±15 %	S26-96392-0	S26-96392-5	$\sqrt{R_{max}6.3}$ 

<sup>1)</sup> Details see chapter 12, series SPP.

**R6V with vent function**

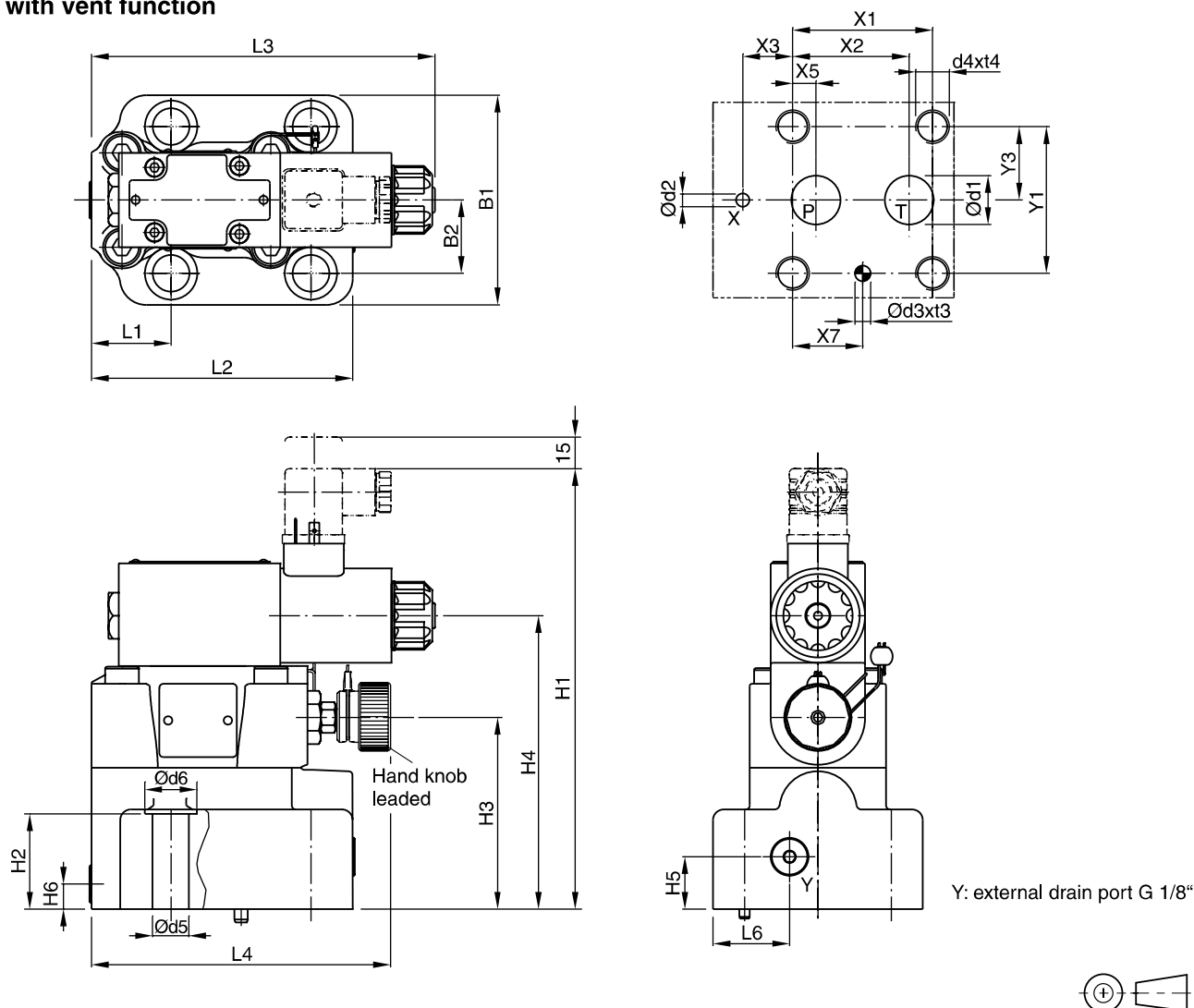



**4**

NG	ISO-code	x1	x2	x3	x4	x5	x6	x7	y1	y2	y3	y4	y5	y6
25	6264-08-13-*-97	66.7	55.6	23.8	-	11.1	-	33.4	70	-	35	-	-	-
32	6264-10-17-*-97	88.9	76.2	31.8	-	12.7	-	44.5	82.6	-	41.3	-	-	-

Tolerance at X and Y pin holes and screw holes ±0.1, at port holes ±0.2.

NG	ISO-code	B1	B2	H1	H2	H3	H4	H5	H6	L1	L2	L3	L4	L6
25	6264-08-13-*-97	100	35	206.9	46.5	91.5	139.8	25	12	37.9	124.5	163.8	141	36.5
32	6264-10-17-*-97	120	41.3	213.9	51.3	98.5	146.8	25	12	44.3	153	163.8	141	36.5

NG	ISO-code	d1max	d2max	d3	t3	d4	t4	d5	d6	Subplate <sup>1)</sup>
25	6264-08-13-*-97	23.4	6.3	7.5	10	M16	27	17.5	25	SPP 6R10B 910
32	6264-10-17-*-97	32	6.3	7.5	10	M18	28	20	30	SPP 10R12B 910

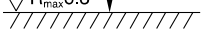
NG	Bolt kit			Kit		Surface finish
				NBR	FPM	
25	BK366	4x M16x70 ISO 4762-12.9	264 Nm ±15 %	S26-96396-0	S26-96396-5	$\sqrt{R_{max}6.3}$ $\square 0.01/100$
32	BK507	4x M18x75 ISO 4762-12.9	398 Nm ±15 %	S26-96392-0	S26-96392-5	

<sup>1)</sup> Details see chapter 12, series SPP.

Dimensions

R4V

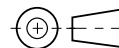
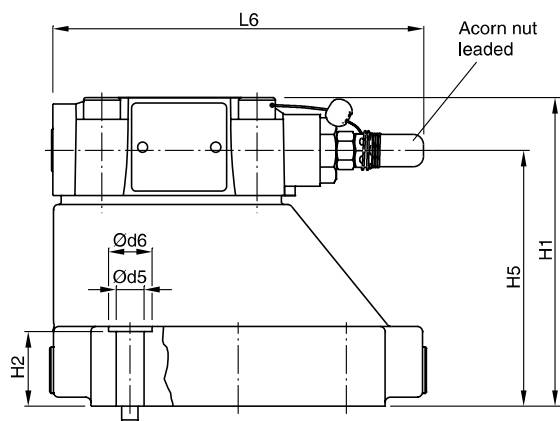
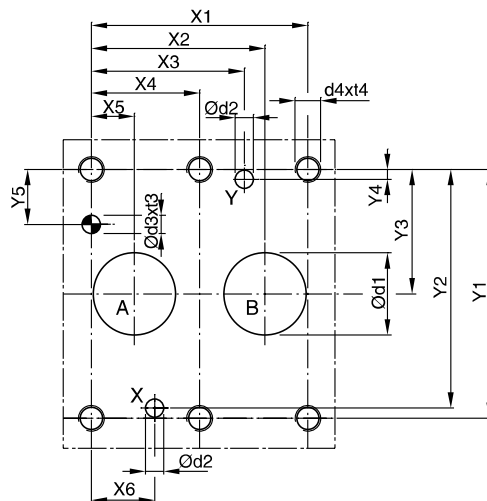
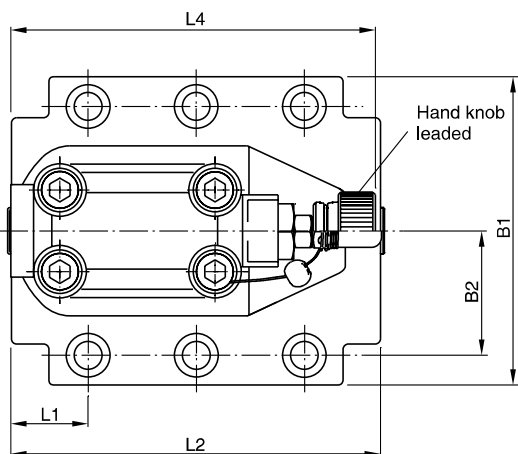



NG	ISO-code	x1	x2	x3	x4	x5	x6	x7	y1	y2	y3	y4	y5	y6
10	6264-06-07-* <sup>-97</sup>	42.9	35.8	21.5	–	7.2	21.5	0	66.7	58.8	33.4	7.9	14.3	–
25	6264-08-11-* <sup>-97</sup>	60.3	49.2	39.7	–	11.1	20.6	0	79.4	73	39.7	6.4	15.9	–
32	6264-10-15-* <sup>-97</sup>	84.2	67.5	59.5	42.1	16.7	24.6	0	96.8	92.8	48.4	3.8	21.4	–

Tolerance at X and Y pin holes and screw holes ±0.1, at port holes ±0.2.

NG	ISO-code	B1	B2	H1	H2	H3	H4	H5	H6	L1	L2	L4	L6
10	6264-06-07-* <sup>-97</sup>	87.3	33.35	83	21	–	–	62.5	–	25	90.8	143	144.8
25	6264-08-11-* <sup>-97</sup>	105	39.7	107.5	29	–	–	87	–	30.9	123	143	144.8
32	6264-10-15-* <sup>-97</sup>	120	48.4	120	30	–	–	99.5	–	29.8	143.5	143	144.8

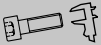
NG	ISO-code	d1max	d2max	d3	t3	d4	t4	d5	d6	Subplate <sup>1)</sup>
10	6264-06-07-* <sup>-97</sup>	15	7	7.1	8	M10	16	10.8	17	SPP 3M6B 910
25	6264-08-11-* <sup>-97</sup>	23.4	7.1	7.1	8	M10	18	10.8	17	SPP 6M8B 910
32	6264-10-15-* <sup>-97</sup>	32	7.1	7.1	8	M10	20	10.8	17	SPP 10M12B 910

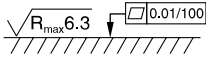
NG	Bolt kit			Kit		Surface finish
				NBR	FPM	
10	BK505	4x M10x35 ISO 4762-12.9	63 Nm ±15 %	S26-58507-0	S26-58507-5	
25	BK485	4x M10x45 ISO 4762-12.9	63 Nm ±15 %	S26-58475-0	S26-58475-5	
32	BK506	6x M10x45 ISO 4762-12.9	63 Nm ±15 %	S26-58508-0	S26-58508-5	

<sup>1)</sup> Details see chapter 12, series SPP.

4

Pressure relief valves of the series RE06M\*W are direct operated proportional valves typically used as remote control valves for flow rates below 3 l/min.

**Function**

When the pressure in port P or A exceeds the pressure setting at the solenoid, the cone opens to port T and limits the pressure in port P to the adjusted level. The optimum performance can be achieved in combination with the digital amplifier module PCD00A-400.

Also available as sandwich valve, see Chapter 8, Pilot valves series RPDM.

**Features**

- Direct operated with proportional solenoid
- Very low pressure adjustment of  $p_{min}$
- 2 pressure ports, A and P
- Subplate mounting according to ISO 6264
- 4 pressure stages

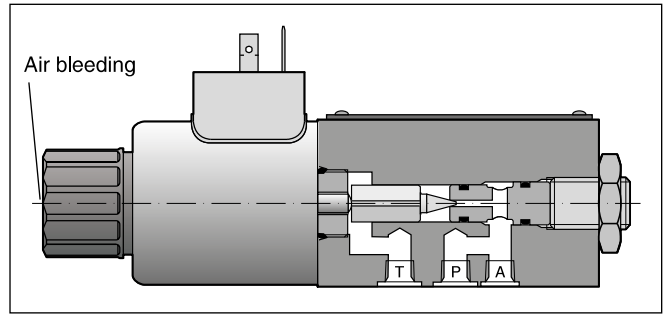
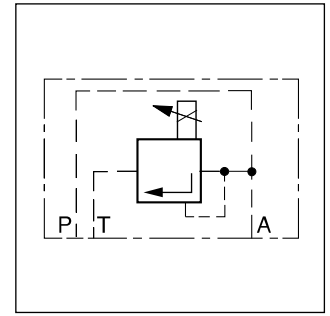

**4**

**Ordering Code**

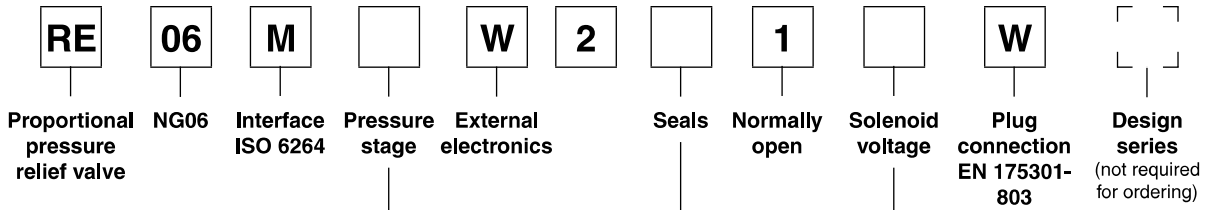

Code	Pressure stage
10	up to 105 bar
<b>17</b>	<b>up to 175 bar</b>
25	up to 250 bar
<b>35</b>	<b>up to 350 bar</b>

Code	Solenoid voltage
<b>K</b>	<b>12 V, 2.5 A</b>
X	16 V, 1.3 A

Code	Seals
N	NBR
<b>V</b>	<b>FPM</b>

**Bold letters =  
Short-term availability**

**Technical Data**

General		
Nominal size		DIN NG06 / CETOP 03 / NFPA D03
Interface		Subplate mounting according to ISO 6264
Mounting position		Unrestricted, horizontal mounting preferred
Ambient temperature	[°C]	-20 ... +60
MTTF <sub>D</sub> value	[years]	150
Weight	[kg]	1.8
Hydraulic		
Max. operating pressure	[bar]	Ports P and A up to 350; port T 30
Pressure stages	[bar]	105, 175, 250, 350
Nominal flow	[l/min]	See p/Q curves
Fluid		Hydraulic oil according to DIN 51524
Viscosity, permitted	[cSt] / [mm <sup>2</sup> /s]	20 ... 400
Viscosity, recommended	[cSt] / [mm <sup>2</sup> /s]	30 ... 80
Fluid temperature	[°C]	-20...+70 (NBR: -25...+70)
Filtration		ISO 4406 (1999); 18/16/13
Linearity	[%]	±2.8
Repeatability	[%]	<±1
Hysteresis	[%]	±1.5 of p <sub>max</sub>
Electrical		
Duty ratio	[%]	100 ED
Protection class		IP65 in accordance with EN 60529 (with correctly mounted plug-in connector)
Nominal voltage	[V]	12 (2.5 A max. current), 16 (1.3 A max. current)
Coil resistance at 20 °C	[Ohm]	4.28 (at 12 V), 12 (at 16 V)
Solenoid connection		Connector as per EN 175301-803
Power amplifier, recommended		PCD00A-400

4



**p/Q curves**

**Pressure stage 105 bar**

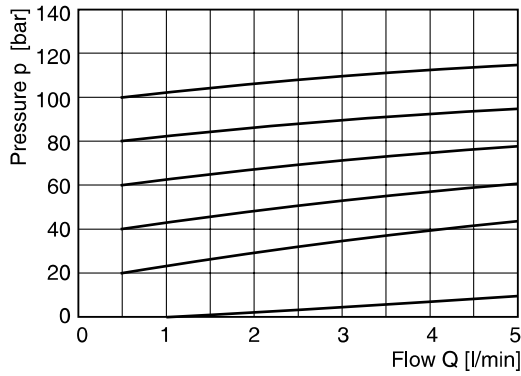

**Pressure stage 350 bar**

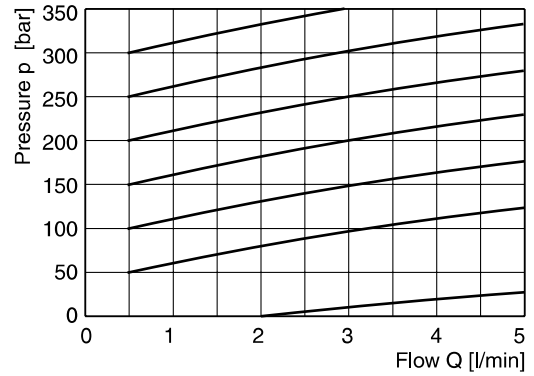

**Min. adjusted pressure**  
**Pressure stage 105 bar**

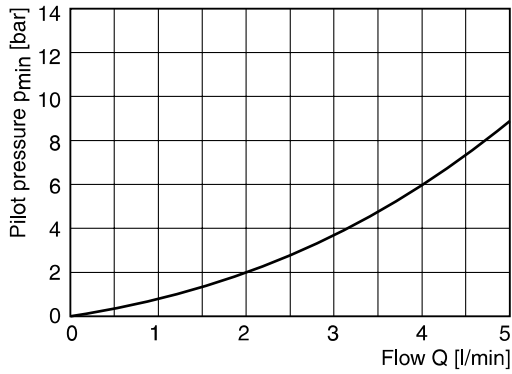

**Pressure stage 350 bar**

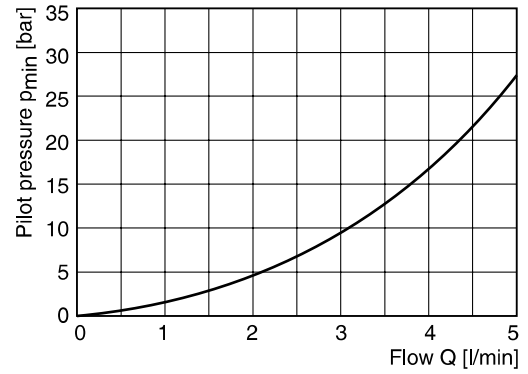

**Pressure/signal curve**  
**Pressure stage 105 bar**

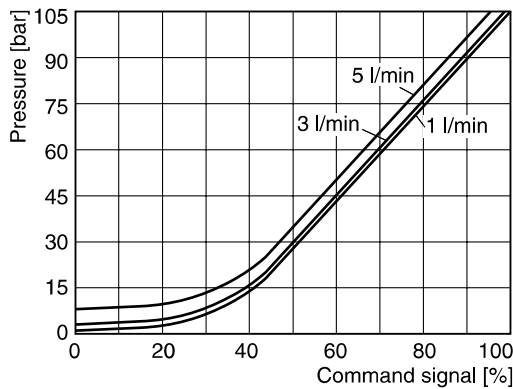

**Pressure stage 350 bar**

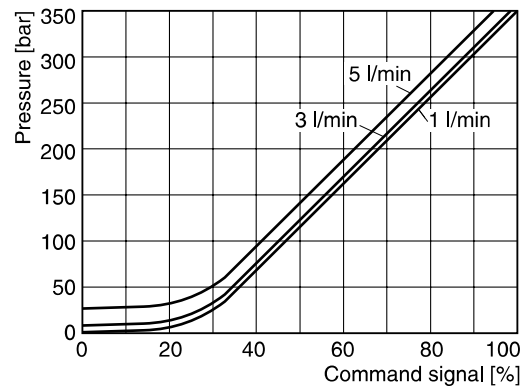

All characteristic curves measured with HLP46 at 50 °C.

RE06MW UK.indd 25.04.2019



Dimensions

RE06M\*W

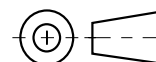
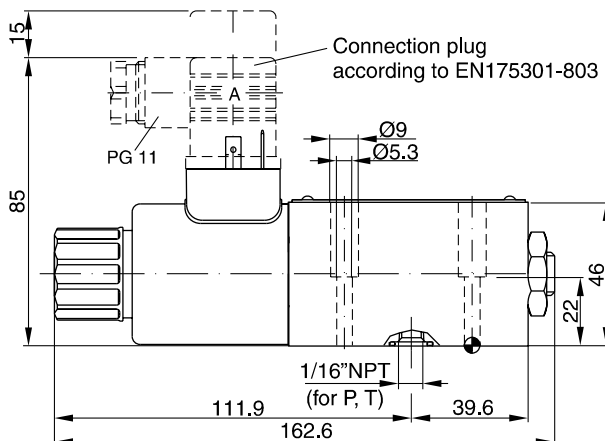
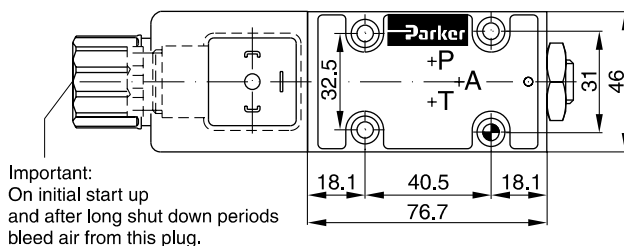

Surface finish	Bolt kit			Kit	
				NBR	FPM
	BK375	4x M5x30 ISO 4762-12.9	7.6 Nm ±15 %	SK-RE06MWN	SK-RE06MWV

Mounting pattern ISO 6264-03-04-\* -97

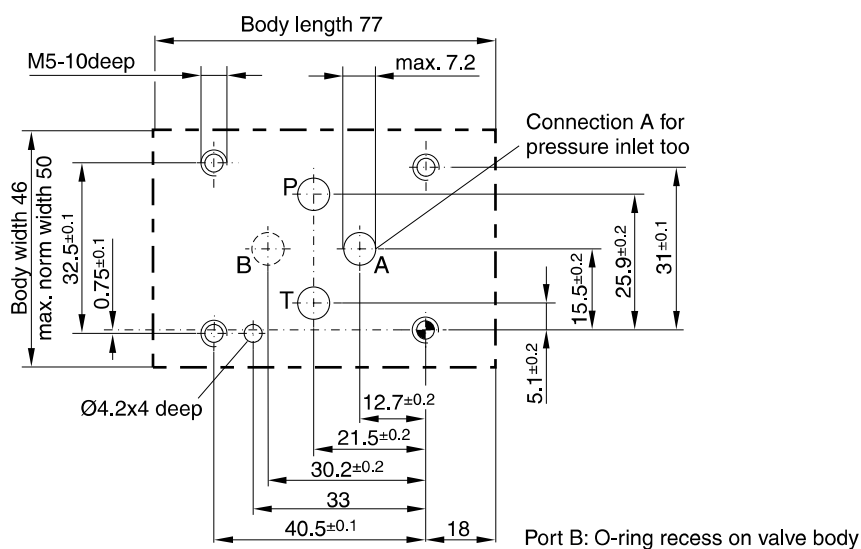

The proportional pressure relief valve series RE06M\*T (NG06) with onboard electronics is based on the functionality of the digital amplifier PCD00. The digital onboard electronics is situated in a robust metal housing and can be used in rough environments. The nominal values of the valves are factory set. Additionally the ProPxD software permits the editing of all parameters. The software is also used for the digital electronic modules. The cable for connection to a serial RS232C interface is available as accessory.

The electrical connection is available in 2 options:

- Code F: 6 + PE central connection  
+/- 10 V command signal  
+10 V reference voltage output
- Code R: 6 + PE central connection  
4...20 mA command signal

**Function**

When the pressure in port P or A exceeds the pressure setting at the solenoid, the cone opens to port T and limits the inlet pressure to the adjusted level.

The pressure adjustment is effected by applying current to the solenoid. The control signal is modulated to the solenoid current by the electronics.

**Features**

- Direct operated with proportional solenoid
- Onboard electronics
- Very low pressure adjustment of  $p_{min}$
- Subplate mounting acc. to ISO 6264
- 6 pressure stages
- 2 pressure inlet ports A and P

**Ordering code**

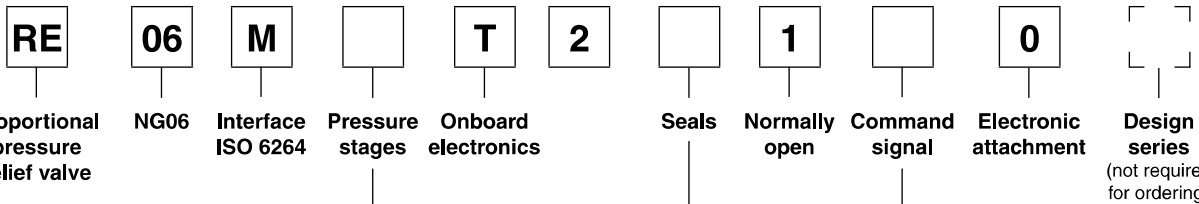

Code	Pressure stages
05	50 bar
10	105 bar
17	<b>175 bar</b>
21	<b>210 bar</b>
25	250 bar
35	<b>350 bar</b>

Code	Command signal
F	<b>Voltage input 0...+10 V with reference output +10 V</b>
R	Current input 4...20 mA

Code	Seals
N	NBR
V	<b>FPM</b>

**Bold letters = Short-term availability**

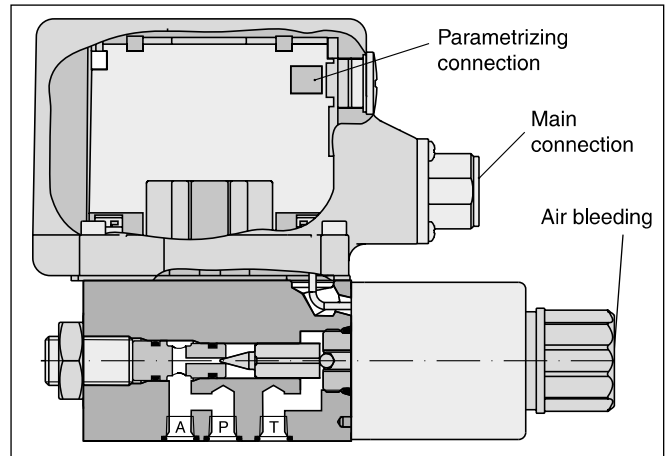
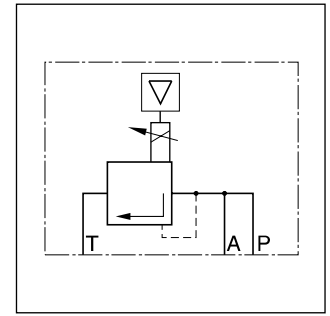

**4**

Please order plugs separately, see chapter 4, accessories.  
Parametrizing cable OBE → RS232, Item no. 40982923

**Technical Data**

General		
Nominal size		DIN NG06 / CETOP 03 / NFPA D03
Interface		Subplate mounting according to ISO 6264
Mounting position		Unrestricted, horizontal mounting preferred
Ambient temperature	[°C]	-20...+60
MTTF <sub>D</sub> value <sup>1)</sup>	[years]	150
Weight	[kg]	2.2
Vibration strength	[g]	10 sinus 5...2000 Hz acc. to IEC 68-2-6 10 (RMS) noise 20...2000 Hz acc. to IEC 68-2-36 15 shock acc. to IEC 68-2-27
Hydraulic		
Max. operating pressure	[bar]	Ports A and P 350, connection T 30
Pressure stages	[bar]	50, 105, 175, 210, 250, 350
Nominal flow	[l/min]	See p/Q curves
Fluid		Hydraulic oil according to DIN 51524
Viscosity, permitted	[cSt] / [mm <sup>2</sup> /s]	20 ... 400
recommended	[cSt] / [mm <sup>2</sup> /s]	30 ... 80
Fluid temperature	[°C]	-20...+70 (NBR: -25...+70)
Filtration		ISO 4406; 18/16/13
Linearity	[%]	See curve
Repeatability	[%]	<±1
Hysteresis	[%]	±1.5 of p <sub>max</sub>
Electrical		
Duty ratio ED	[%]	100
Protection class		IP65 in accordance with EN 60529 (with correctly mounted plug-in connector)
Supply voltage	[VDC]	18...30, ripple < 5 % eff., surge free
Current consumption max.	[A]	2.0
Pre-fusing	[A]	2.5 medium lag
Potentiometer supply	[V]	+10 / ±5 % max. 10 mA
Command signal		
Code F voltage	[V]	0...+10, ripple < 0.01 % eff., surge free, Ri = 100 kOhm
Code R current	[mA]	4...20, ripple < 0.01 % eff., surge free, Ri = <250 Ohm < 3.6 mA = enable off, > 3.8 mA = enable on (acc. NAMUR NE43)
Differential input voltage max.	[V]	30 for terminal D and E against PE (terminal G)
	[V]	11 for terminal D and E against 0V (terminal B)
Adjustment ranges		
Min current	[%]	0...50
Max current	[%]	50...100
Ramp	[s]	0...32.5
Interface		RS 232C, parametrizing connection 5polig
EMC		EN 61000-6-2, EN 61000-6-4
Central connection		6 + PE acc. EN 175201-804
Cable specification	[mm <sup>2</sup> ]	7 x 1.0 overall braid shield
Cable length max.	[m]	50

<sup>1)</sup> If valves with onboard electronics are used in safety-related parts of control systems, in case the safety function is requested, the valve electronics voltage supply is to be switched off by a suitable switching element with sufficient reliability.

**Signal/pressure curve**

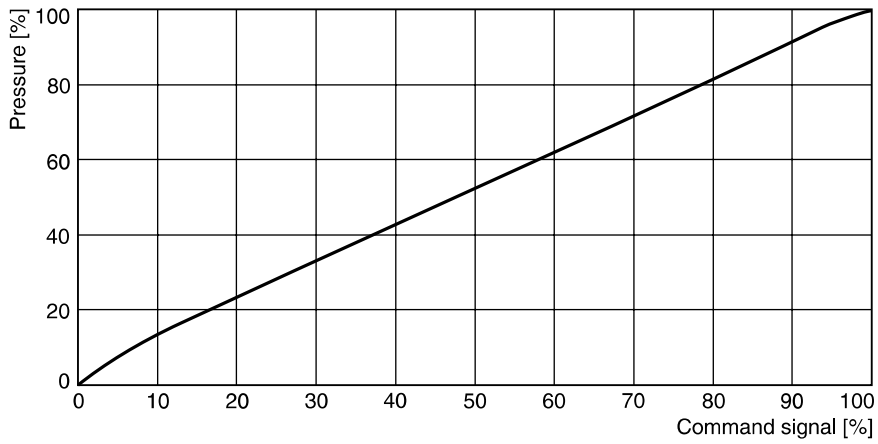

**4**

**Min. adjusted pressure**

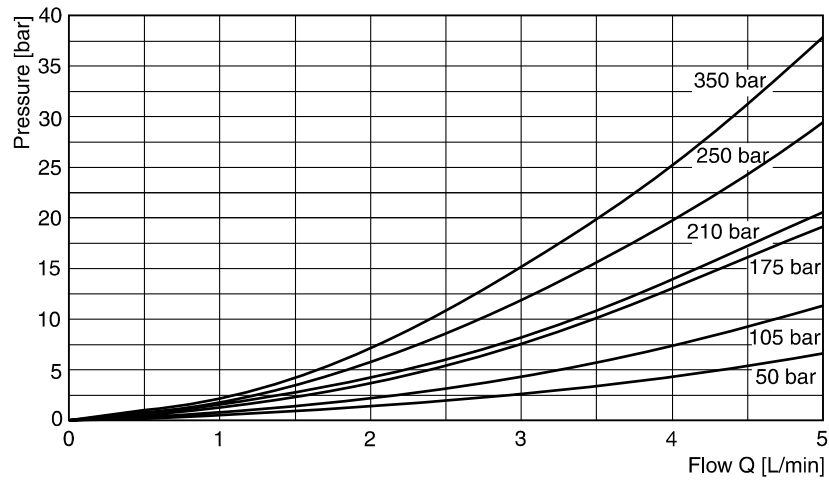

**p/Q curve**

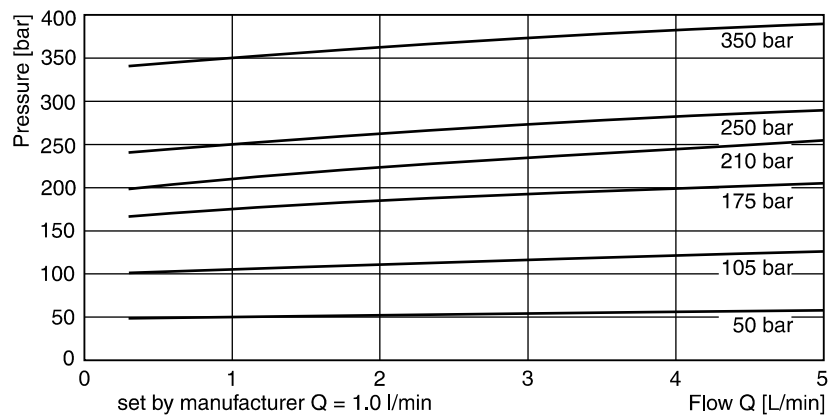

All characteristic curves measured with HLP46 at 50 °C.

RE06MT UK.indd 25.04.2019



**Electronics**

**Block diagram**

**Code F**

**6 + PE acc. EN 175201-804**

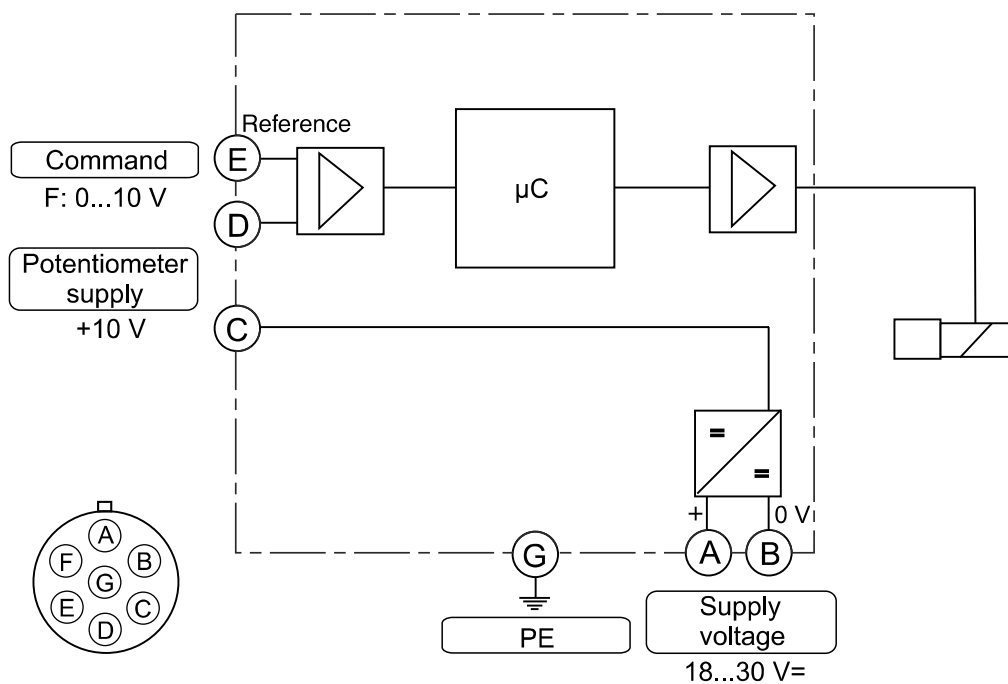

**Code R**

**6 + PE acc. EN 175201-804**

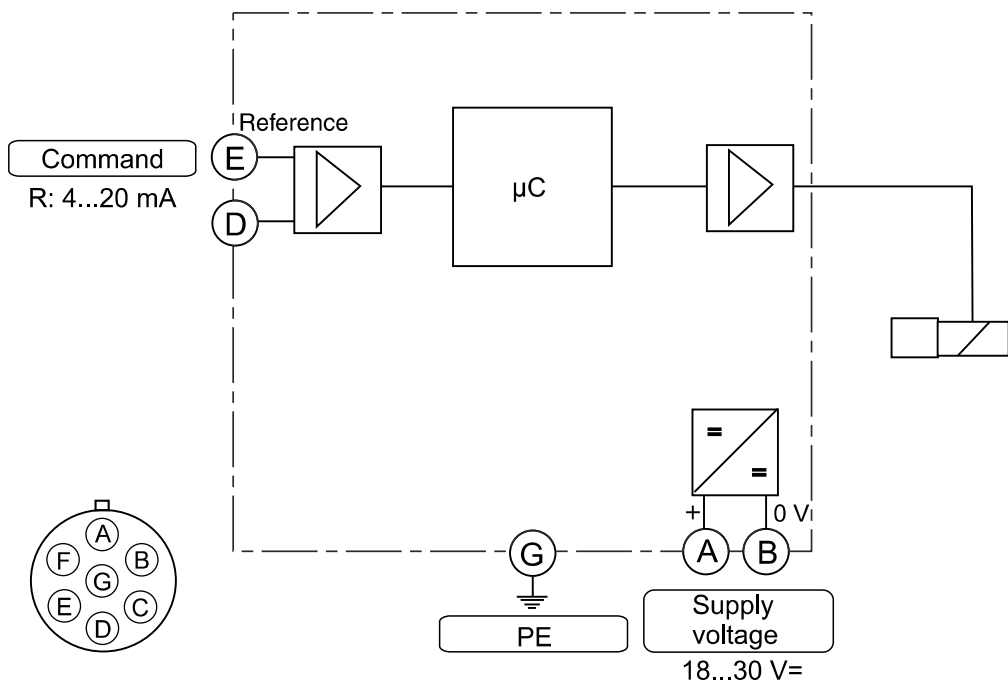

4

**ProPxD interface program**

The ProPxD software permits comfortable parameter setting for the module electronics. Via the clearly arranged entry mask the parameters can be noticed and modified. Storage of complete parameter sets is possible as well as printout or record as a text file for further documentation. Stored parameter sets may be loaded anytime and transmitted to other valves. Inside the electronics a non-volatile memory stores the data with the option for recal-ling or modification.

The PC software can be downloaded free of charge at [www.parker.com/isde](http://www.parker.com/isde) – see page “Support“ or directly at [www.parker.com/propxd](http://www.parker.com/propxd).

**Features**

- Comfortable editing of all parameters
- Depiction and documentation of parameter sets
- Storage and loading of optimized parameter adjust-ments
- Executable with all actual Windows® operating systems from Windows® XP upwards
- Plain communication between PC and electronics via serial interface RS232C

**The parametrizing cable may be ordered under item no. 40982923.**

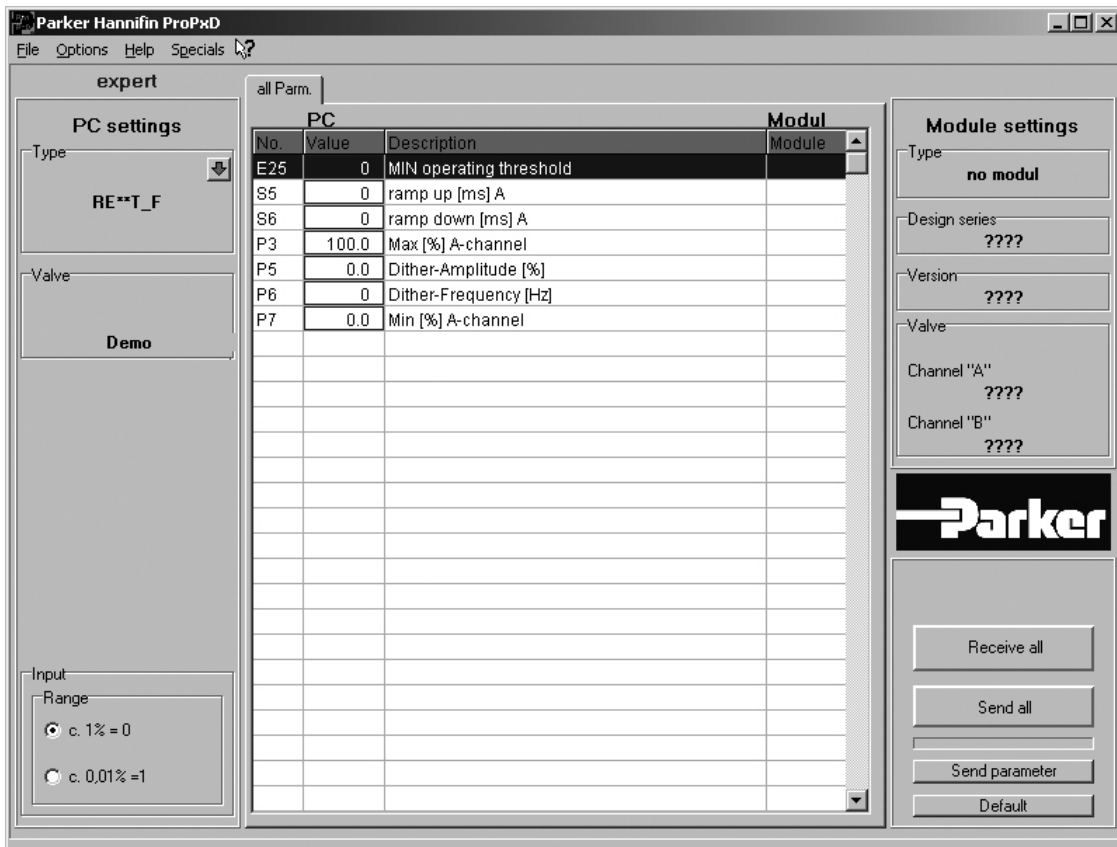

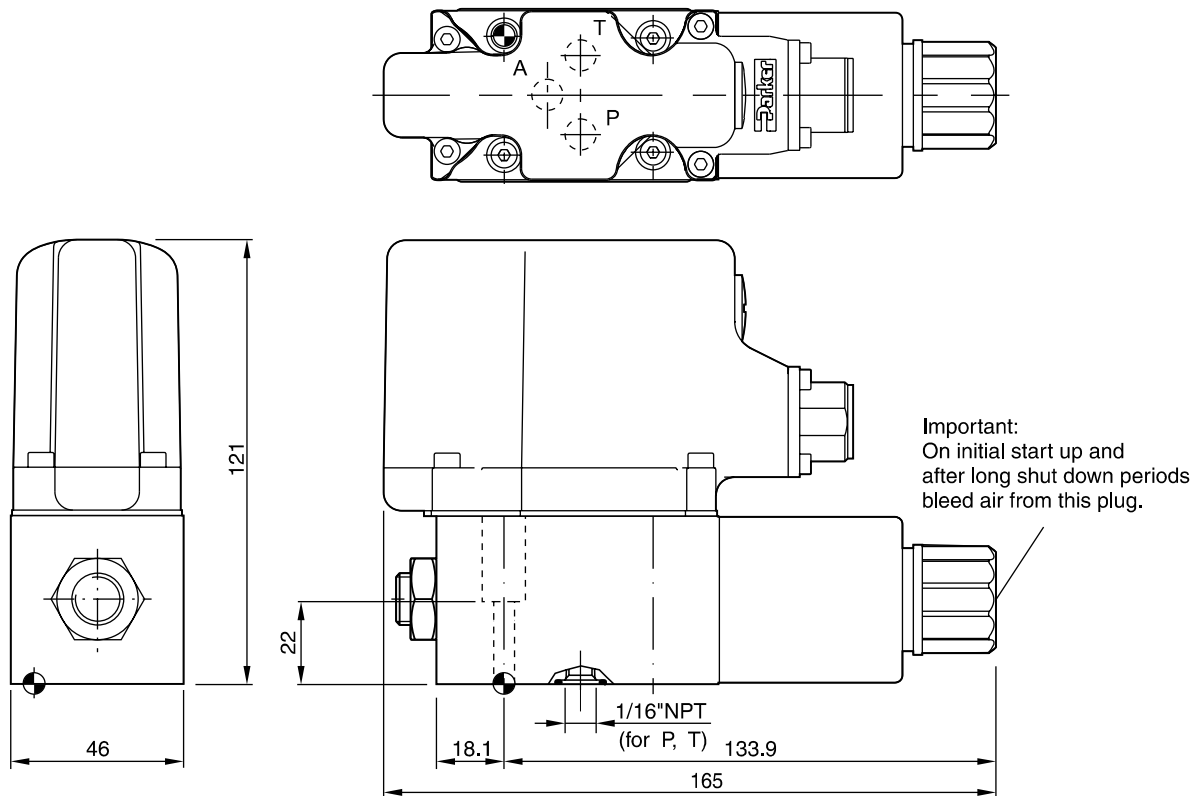

Dimensions

4

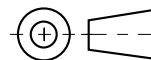

Important:  
On initial start up and  
after long shut down periods  
bleed air from this plug.

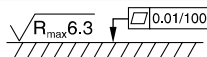

Surface finish	Bolt kit			Kit	
				NBR	FPM
	BK 375	4x M5x30 ISO 4762-12.9	7.6 Nm ±15 %	SK-RE06MTN	SK-RE06MTV

Mounting pattern ISO 6264-03-04-\* -97

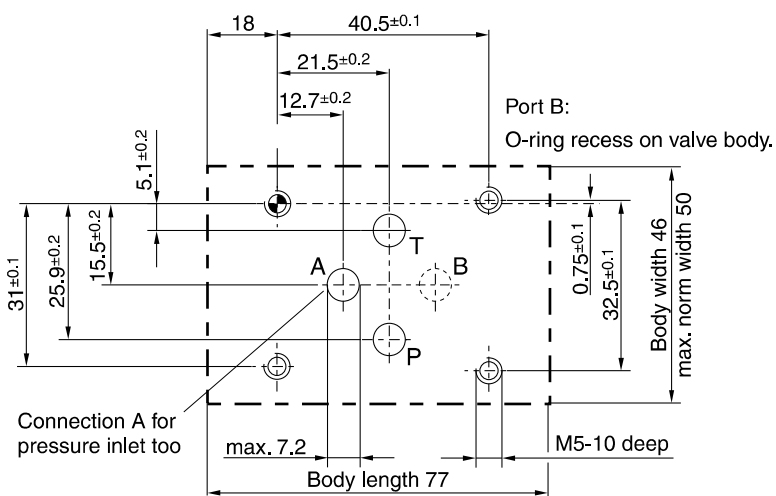



**Characteristics**

Pilot operated proportional pressure relief valves series R4V (DIN 24340 Form D) and R6V (DIN 24340 Form E) consist of a proportionally adjusted pilot stage and a seated type main stage.

The optimum performance can be achieved in combination with the digital amplifier module PCD00A-400.

**Features**

- Pilot operated with proportional solenoid
- 2 interfaces:
  - R4V subplate ISO 6264 (DIN 24340 Form D)
  - R6V subplate ISO 6264 (DIN 24340 Form E)
- 3 pressure stages
- Mechanical maximum pressure adjustment (optional for R6V)

**Pilot Operated Prop. Pressure Relief Valves Series R4V / R6V (Proportional)**



R6V06



R4V06

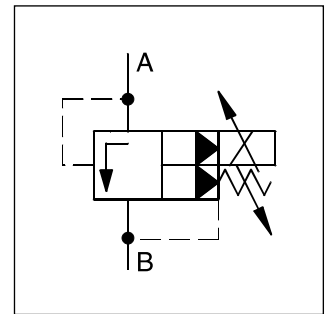
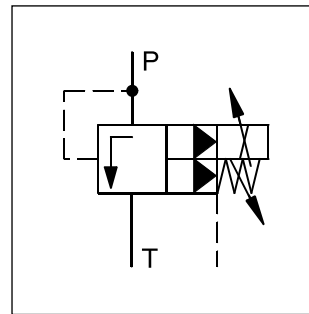

4

**R6V06**

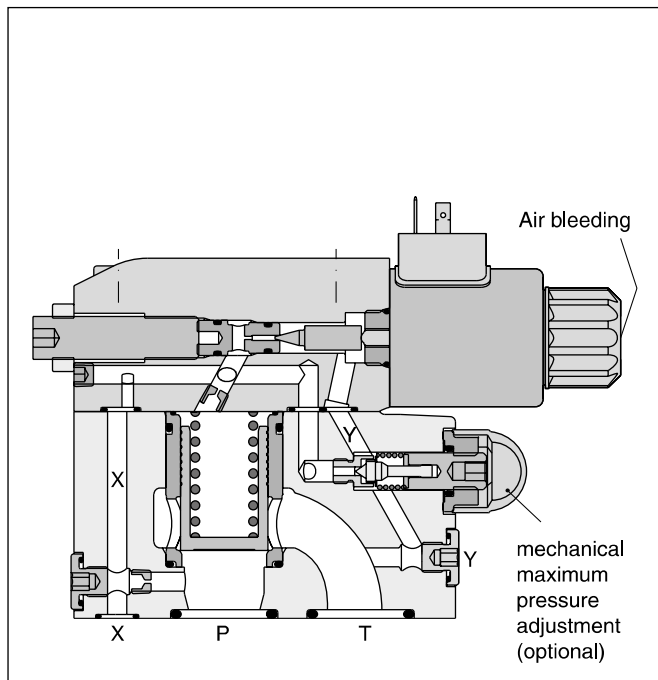

**R4V06**

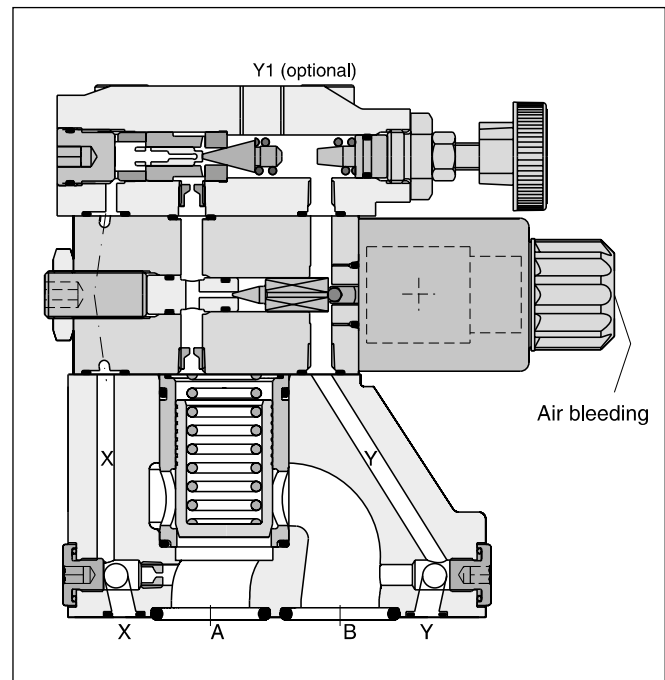

Ordering Code

4

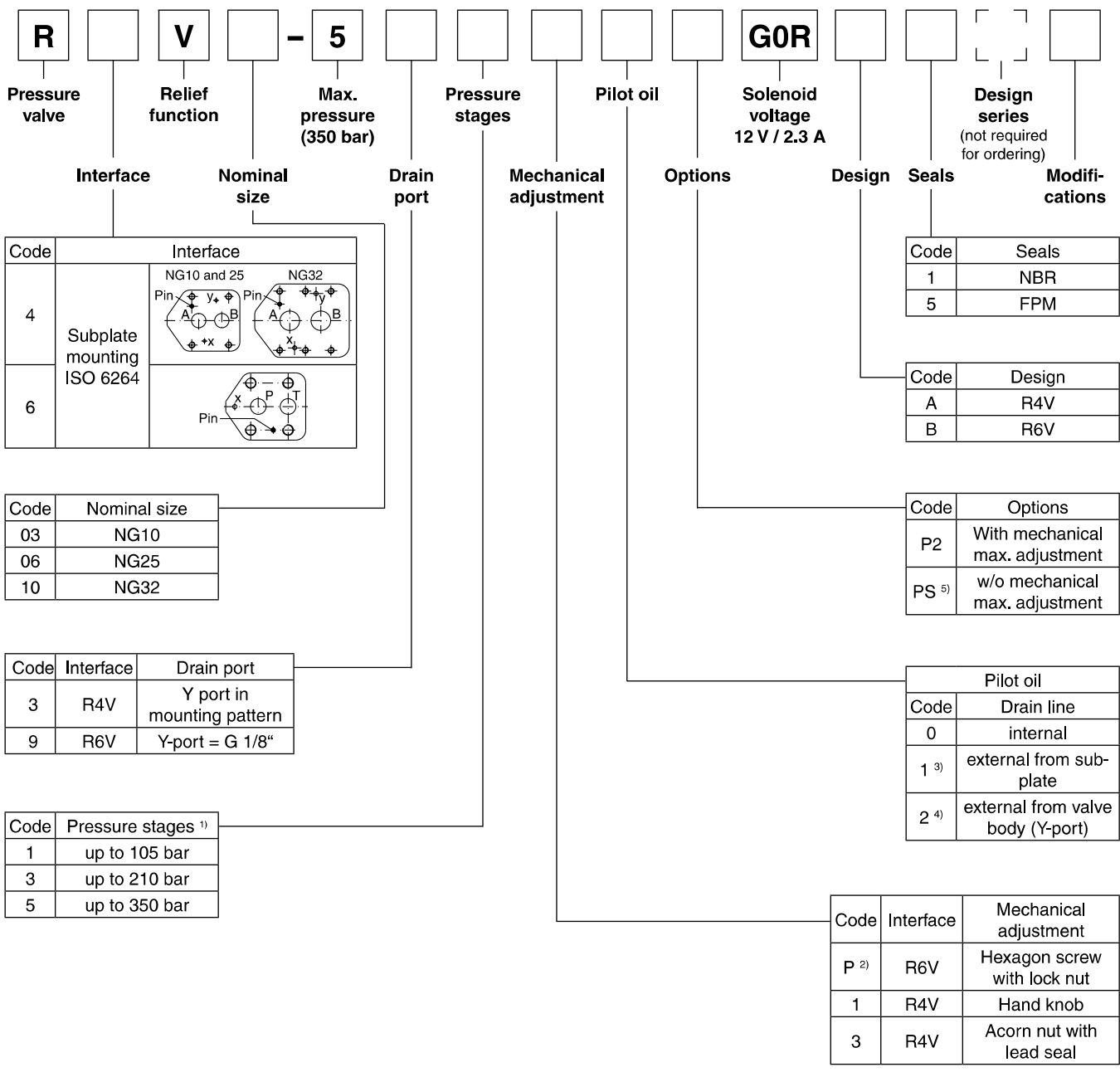

<sup>1)</sup> Other pressure stages on request.

<sup>2)</sup> Use code P also for valve w/o mechanical adjustment.

<sup>3)</sup> R4V only.

<sup>4)</sup> R6V only.

<sup>5)</sup> Not for R4V.

**Technical Data**

<b>General</b>					
Nominal size		<b>10</b>	<b>25</b>	<b>32</b>	
Interface	Subplate mounting acc. ISO 6264				
Mounting position	Unrestricted, horizontal mounting preferred				
Ambient temperature	[°C]	-20...+60			
MTTF <sub>D</sub> value	[years]	75			
Weight	Series R6V	[kg]	5.2	6.4	8.3
	Series R4V	[kg]	4.5	6.3	7.8
<b>Hydraulic</b>					
Max. operating pressure	[bar]	Ports P (or A) and X up to 350, port T (or B) and Y 30			
Pressure stages	[bar]	105, 210, 350			
Nominal flow	[l/min]	250	500	650	
Fluid	Hydraulic oil according to DIN 51524				
Viscosity, permitted	[cSt] / [mm <sup>2</sup> /s]	20 ... 400			
	recommended	[cSt] / [mm <sup>2</sup> /s]	30 ... 80		
Fluid temperature	[°C]	-20...+70 (NBR: -25...+70)			
Filtration	ISO 4406 (1999); 18/16/13				
<b>Electrical (prop. solenoid)</b>					
Duty ratio	[%]	100 ED; CAUTION: coil temperature up to 150 °C possible			
Protection class	IP65 in accordance with EN 60529 (with correctly mounted plug-in connector)				
Supply voltage	[V]	12 V =			
Max. current	[A]	2.1			
Coil resistance at 20 °C	[Ohm]	4.28			
Solenoid connection	Connector as per EN 175301-803				
Power amplifier, recommended	PCD00A-400				

4

**R4V Signal/pressure curve**

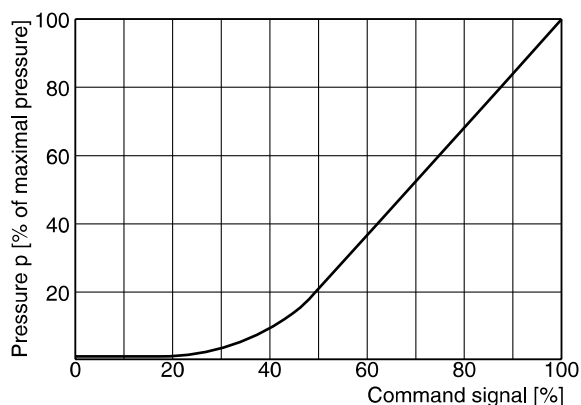

**R6V Signal/pressure curve**

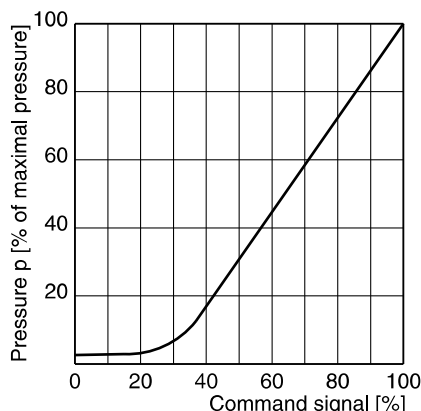

**p/Q performance curves <sup>1)</sup>**

**R4V / R6V03**

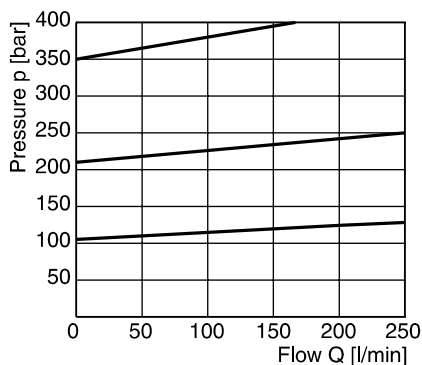

**R4V / R6V06**

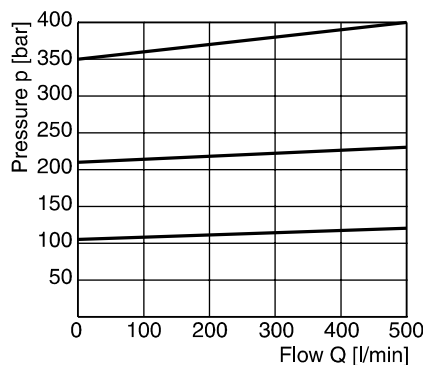

**R4V / R6V10**

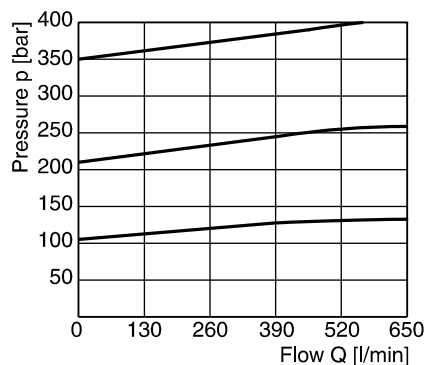

**Minimum pressure curves <sup>1)</sup>**

**R4V / R6V03**

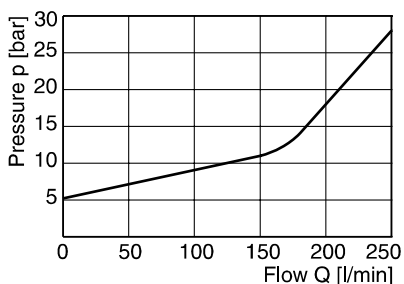

**R4V / R6V06**

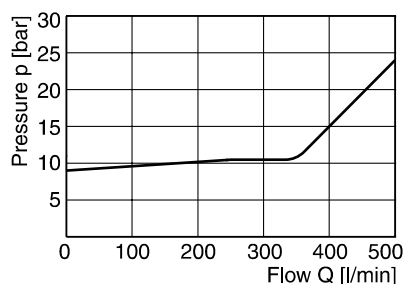

**R4V / R6V10**

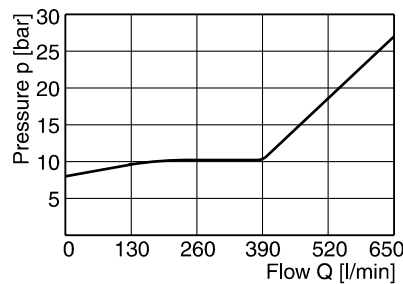

All characteristic curves measured with HLP46 at 50 °C.

<sup>1)</sup> The performance curves are measured with external drain.  
 For internal drain the tank pressure has to be added to curve.

**R4V**

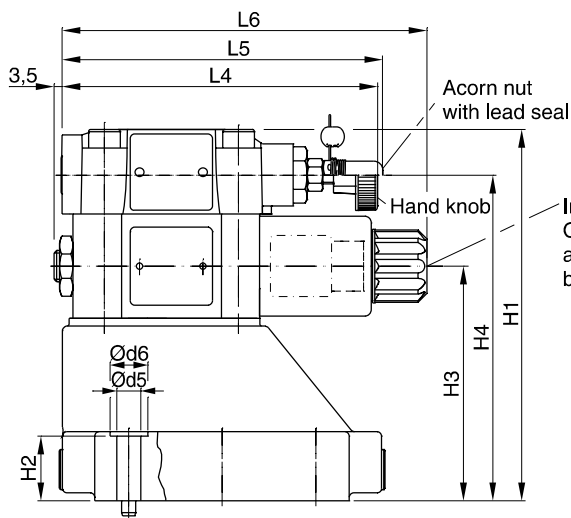
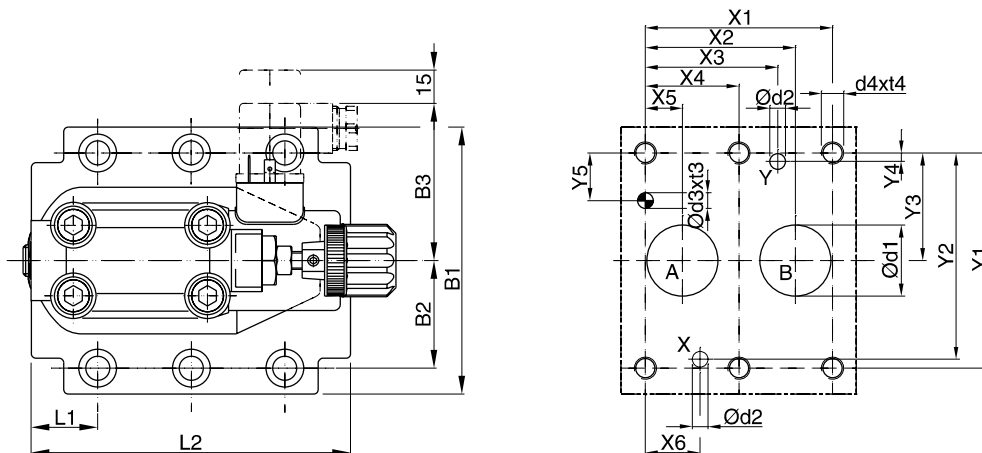

Important:  
 On initial start up  
 and after long shut down periods  
 bleed air from this plug.

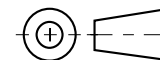

NG	ISO-code	x1	x2	x3	x4	x5	x6	x7	y1	y2	y3	y4	y5	y6
10	6264-06-07-*-97	42.9	35.8	21.5	–	7.2	21.5	0	66.7	58.8	33.4	7.9	14.3	–
25	6264-08-11-*-97	60.3	49.2	39.7	–	11.1	20.6	0	79.4	73	39.7	6.4	15.9	–
32	6264-10-15-*-97	84.2	67.5	59.5	42.1	16.7	24.6	0	96.8	92.8	48.4	3.8	21.4	–

Tolerance at X and Y pin holes and screw holes ±0.1, at port holes ±0.2.

NG	ISO-code	B1	B2	B3	H1	H2	H3	H4	H6	L1	L2	L3	L4	L5	L6
10	6264-06-07-*-97	87.3	33.35	71	130	21	68.5	109.5	–	25	90.8	–	143	144.8	164.8
25	6264-08-11-*-97	105	39.7	71	154.5	29	93	134	–	30.9	123	–	143	144.8	164.8
32	6264-10-15-*-97	120	48.4	71	167	30	105.5	146.5	–	29.8	143.5	–	143	144.8	164.8

NG	ISO-code	d1max	d2max	d3	t3	d4	t4	d5	d6	Subplate <sup>1)</sup>
10	6264-06-07-*-97	15	7	7.1	8	M10	16	10.8	17	SPP 3M6B 910
25	6264-08-11-*-97	23.4	7.1	7.1	8	M10	18	10.8	17	SPP 6M8B 910
32	6264-10-15-*-97	32	7.1	7.1	8	M10	20	10.8	17	SPP 10M12B 910

NG	Bolt kit			Kit		Surface finish
				NBR	FPM	
10	BK505	4x M10x35 ISO 4762-12.9	63 Nm ±15 %	S26-58507-0 <sup>2)</sup>	S26-58507-5 <sup>2)</sup>	
25	BK485	4x M10x45 ISO 4762-12.9	63 Nm ±15 %	S26-58475-0 <sup>2)</sup>	S26-58475-5 <sup>2)</sup>	
32	BK506	4x M10x45 ISO 4762-12.9	63 Nm ±15 %	S26-58508-0 <sup>2)</sup>	S26-58508-5 <sup>2)</sup>	
Prop. section P2				S26-58473-0	S26-58473-5	

<sup>1)</sup> Details see chapter 12, series SPP.

<sup>2)</sup> Please combine seal kit of one size with seal kit of prop. section P2 for complete seal kit.

**Dimensions**

**R6V**

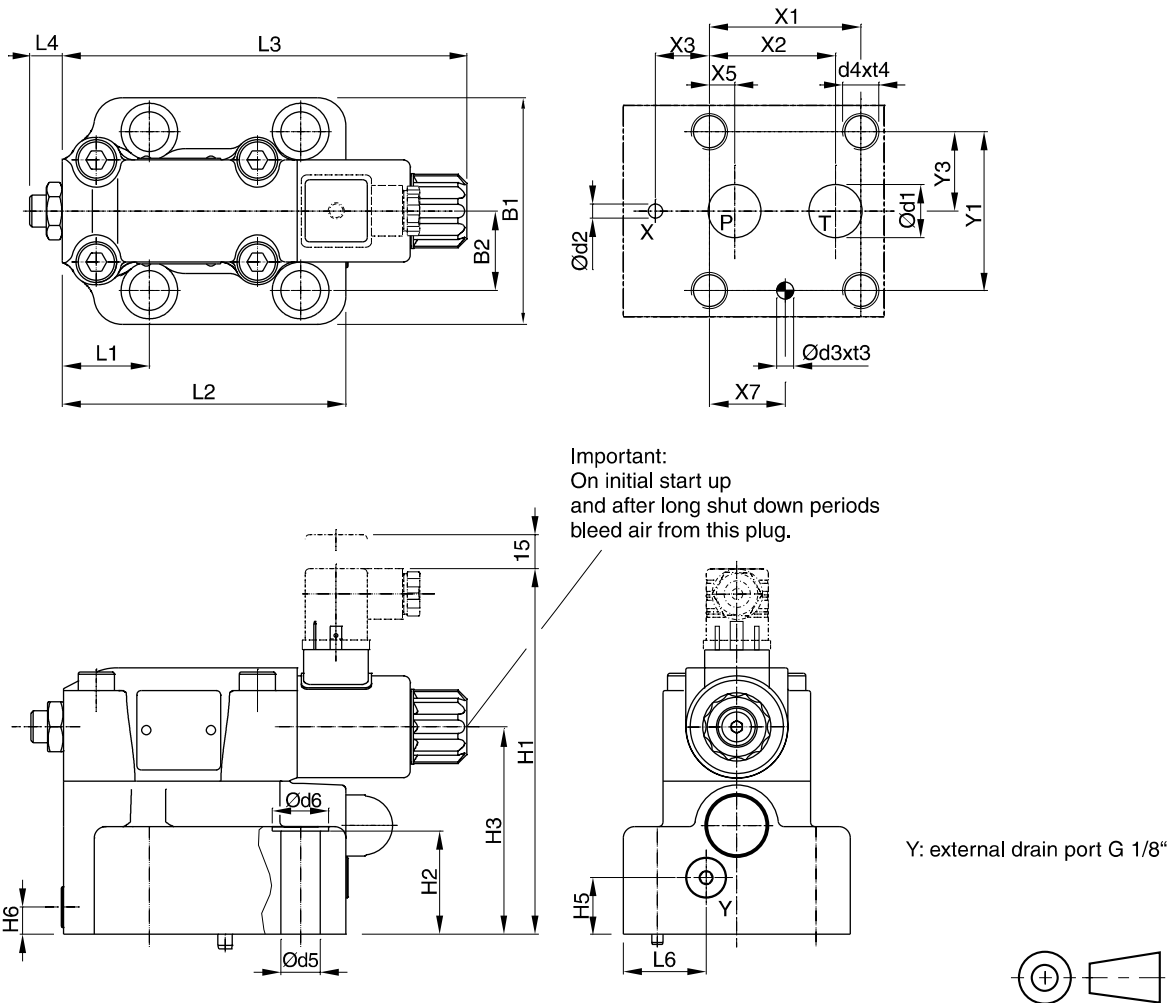

NG	ISO-code	x1	x2	x3	x4	x5	x6	x7	y1	y2	y3	y4	y5	y6
10	6264-06-09-*-97	53.8	47.5	0	-	22.1	-	22.1	53.8	-	26.9	-	-	-
25	6264-08-13-*-97	66.7	55.6	23.8	-	11.1	-	33.4	70	-	35	-	-	-
32	6264-10-17-*-97	88.9	76.2	31.8	-	12.7	-	44.5	82.6	-	41.3	-	-	-

Tolerance at X and Y pin holes and screw holes ±0.1, at port holes ±0.2.

NG	ISO-code	B1	B2	H1	H2	H3	H4	H5	H6	L1	L2	L3	L4	L5	L6
10	6264-06-09-*-97	80	26.9	158.7	27	88	-	20.5	25	52	117	182.3	14.4	-	29.5
25	6264-08-13-*-97	100	35	161.2	46.5	91.5	-	25	12	37.9	124.5	182.3	14.4	-	36.5
32	6264-10-17-*-97	120	41.3	166.7	51.3	98.5	-	26.5	13.5	44.3	153	182.3	14.4	-	46.5

NG	ISO-code	d1max	d2max	d3	t3	d4	t4	d5	d6	Subplate <sup>1)</sup>
10	6264-06-09-*-97	14.7	4.8	7.5	10	M12	20	13.5	20	SPP 3R6B 910
25	6264-08-13-*-97	23.4	6.3	7.5	10	M16	27	17.5	25	SPP 6R10B 910
32	6264-10-17-*-97	32	6.3	7.5	10	M18	28	20	30	SPP 10R12B 910

NG	Bolt kit			Kit		Surface finish
				NBR	FPM	
10	BK494	4x M12x45 ISO 4762-12.9	108 Nm ± 15 %	S26-98589-0	S26-98589-5	
25	BK366	4x M16x70 ISO 4762-12.9	264 Nm ± 15 %	S26-96396-0	S26-96396-5	
32	BK507	4x M18x75 ISO 4762-12.9	398 Nm ± 15 %	S26-96392-0	S26-96392-5	

<sup>1)</sup> Details see chapter 12, series SPP.

**Characteristics**

**Pilot Operated Prop. Pressure Relief Valves  
Series R4V / R6V (Onboard Electronics)**

The proportional solenoid operated pilot stage with integrated electronics controls a seated type main stage. The valves are optionally available with a mechanical maximum pressure adjustment.

The onboard electronics of the proportional pressure relief valves is based on the functionality of the digital amplifier PCD00.

The digital onboard electronics is situated in a robust metal housing and can be used in rough environments.

The nominal values of the valves are factory set. Additionally the ProPxD software permits the editing of all parameters. The software is also used for the digital electronic modules. The cable for connection to a serial RS232C interface is available as accessory.

The electrical connection is available in 2 options:

Code 10V: 6 + PE central connection  
0...+10 V command signal  
+10 V reference voltage output

Code 4MA: 6 + PE central connection  
4...20 mA command signal

**Features**

- Pilot operated with proportional solenoid
- Onboard electronics factory set
- Ramp time adjustment
- Linearized characteristics
- 3 pressure stages
- 2 interfaces:
  - R4V subplate ISO 6264 (DIN 24340 Form D)
  - R6V subplate ISO 6264 (DIN 24340 Form E)
- Optional mechanical maximum pressure adjustment



R6V06

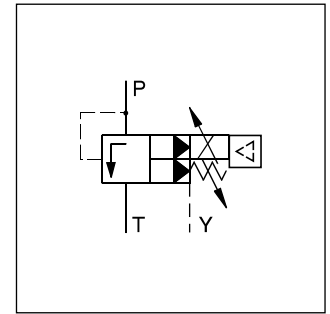

R6V

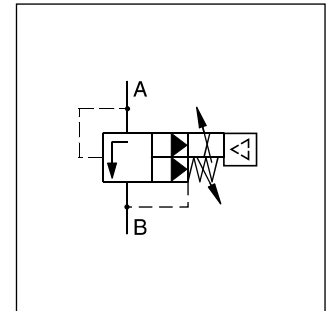

R4V

4

**R4V06**

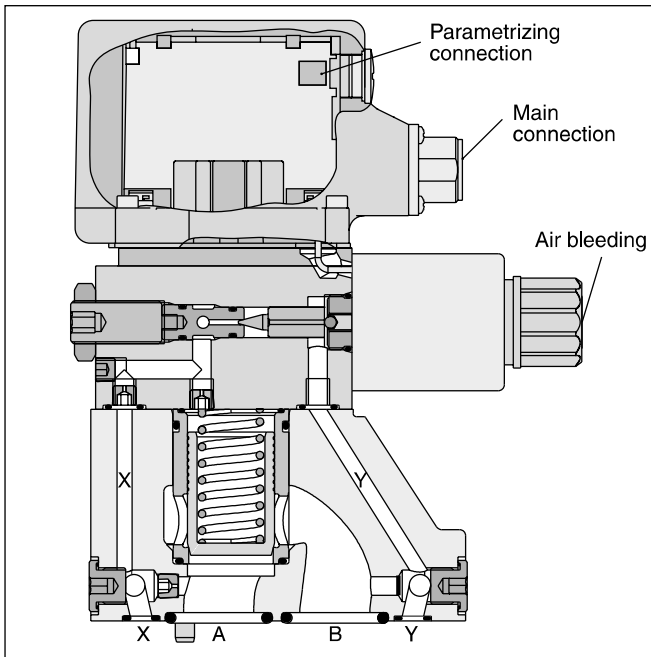

**R6V06**

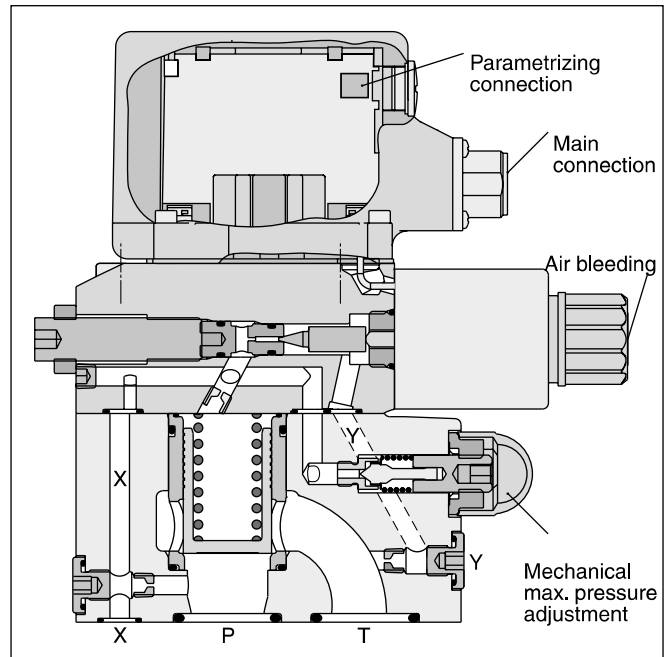

R4V-R6V OBE UK.indd 25.04.19



**4**

<b>R</b>	<b>V</b>	<b>5</b>	<b>P</b>	[ ]	[ ]	[ ]	[ ]	[ ]	[ ]	[ ]	[ ]	[ ]	
Pressure valve	Relief function	Max. pressure (350 bar)	Pressure setting range	Pilot oil	Options	Command signal	Design	Seals	Design series (not required for ordering)	Modifications			
Interface		Nominal size	Drain port	Proportional operation				Design	Seals				
Code		Interface					Code	Seals					
4		Subplate mounting					1	NBR					
6		ISO 6264					5	FPM					
Code		Nominal size					Code		Design				
03		NG10					A		R4V				
06		NG25					B		R6V				
10		NG32					Code		Command signal				
3		R4V		Y from subplate			10V		0...10 V (ref. output +10 V)				
9		R6V		Y-port = G 1/8"			4MA		4...20 mA				
Code		Interface	Drain port					Code		Options			
1		Pressure stages <sup>1)</sup>					PN		w/o mech. max. adjustment				
3		up to 105 bar					PM <sup>4)</sup>		With mech. max. adjustment				
5		up to 210 bar					Pilot oil						
1		up to 350 bar					Code		Drain line				
0		internal					1 <sup>2)</sup>		external from subplate				
2 <sup>3)</sup>		external from valve body (Y-port)					2 <sup>3)</sup>		external from valve body (Y-port)				

Please order plugs separately, see chapter 4, accessories.  
 Parametrizing cable OBE → RS232, item no. 40982923.

<sup>1)</sup> Other pressure stages on request.  
<sup>2)</sup> R4V only.  
<sup>3)</sup> R6V only.  
<sup>4)</sup> R4V: adjustment with acorn nut.





**Technical Data**

General				
Nominal size		NG10	NG25	NG32
Interface		Subplate mounting acc. ISO 6264		
Mounting position		Unrestricted, horizontal mounting preferred		
Ambient temperature [°C]		-20...+60		
MTTF <sub>D</sub> value <sup>1)</sup> [years]		75		
Weight	Series R6V	5.4	6.6	8.6
	Series R4V	4.5	6.3	7.8
Vibration strength [g]		10 sinus 5...2000 Hz acc. to IEC 68-2-6 10 (RMS) noise 20...2000 Hz acc. to IEC 68-2-36 15 shock acc. to IEC 68-2-27		
Hydraulic				
Max. operating pressure [bar]		Ports P (or A) and X up to 350, port T (or B) and Y 30		
Pressure stages [bar]		105, 210, 350		
Nominal flow [l/min]		250	500	650
Fluid		Hydraulic oil according to DIN 51524		
Viscosity, permitted recommended	[cSt] / [mm <sup>2</sup> /s]	20 ... 400		
	[cSt] / [mm <sup>2</sup> /s]	30 ... 80		
Fluid temperature [°C]		-20...+70 (NBR: -25...+70)		
Filtration		ISO 4406; 18/16/13		
Hysteresis [%]		< 1.5		
Electrical				
Duty ratio ED [%]		100		
Protection class		IP65 in accordance with EN 60529 (with correctly mounted plug-in connector)		
Supply voltage VDC		18...30, ripple < 5 % eff., surge free		
Current consumption max. [A]		2.0		
Pre-fusing [A]		2.5 medium lag		
Potentiometer supply [V]		+10 / ±5 % max. 10 mA		
Command signal				
Code 10V voltage [V]		0...+10, ripple < 0.01 % eff., surge free, Ri = 100 kOhm		
Code 4mA current [mA]		4...20, ripple < 0.01 % eff., surge free, Ri = <250 Ohm < 3.6 mA = enable off, > 3.8 mA = enable on (acc. NAMUR NE43)		
Differential input voltage max. [V]		30 for terminal D and E against PE (terminal G)		
		11 for terminal D and E against 0V (terminal B)		
Adjustment ranges	Min current [%]	0...50		
	Max current [%]	50...100		
	Ramp [s]	0...32.5		
Interface		RS232C, parametrizing connection 5pole		
EMC		EN 61000-6-2, EN 61000-6-4		
Central connection		6 + PE acc. EN 175201-804		
Cable specification [mm <sup>2</sup> ]		7 x 1.0 overall braid shield		
Cable length max. [m]		50		

4

<sup>1)</sup> If valves with onboard electronics are used in safety-related parts of control systems, in case the safety function is requested, the valve electronics voltage supply is to be switched off by a suitable switching element with sufficient reliability.



**R4V/R6V**

**Command/pressure curve**

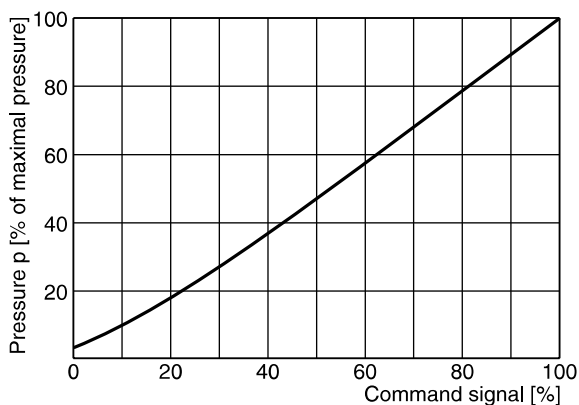

**p/Q performance curves <sup>1)</sup>**

**R4V / R6V03**

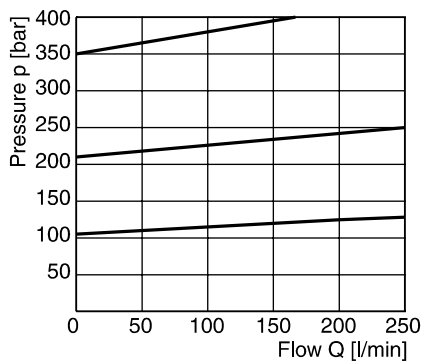

**R4V / R6V06**

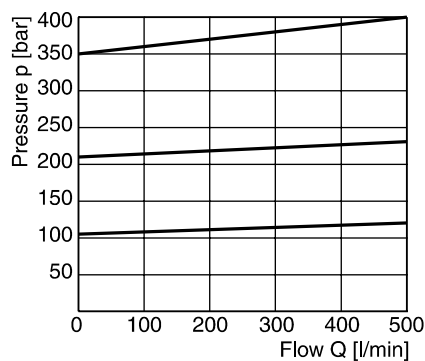

**R4V / R6V10**

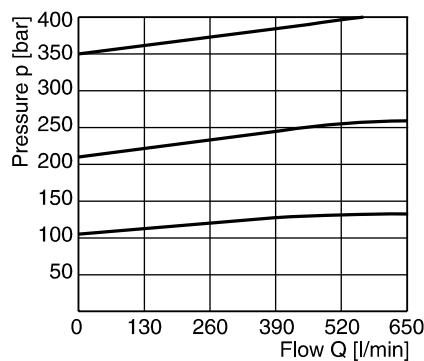

**Minimum pressure curves <sup>1)</sup>**

**R4V / R6V03**

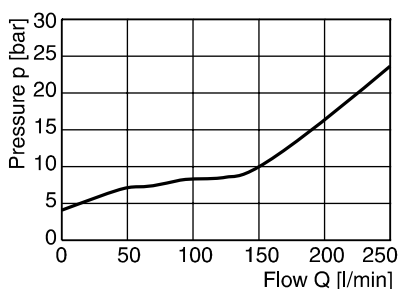

**R4V / R6V06**

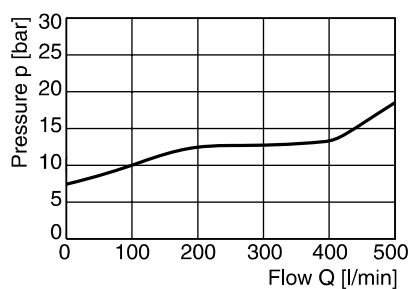

**R4V / R6V10**

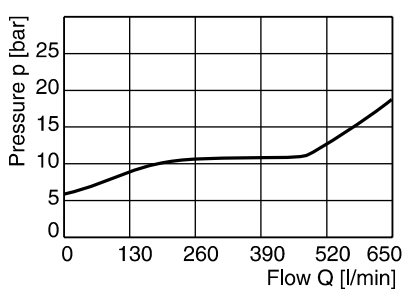

All characteristic curves measured with HLP46 at 50 °C.

<sup>1)</sup> The performance curves are measured with external drain.  
 For internal drain the tank pressure has to be added to curve.

**Block diagram**

**Code 10V**

**6 + PE acc. EN 175201-804**

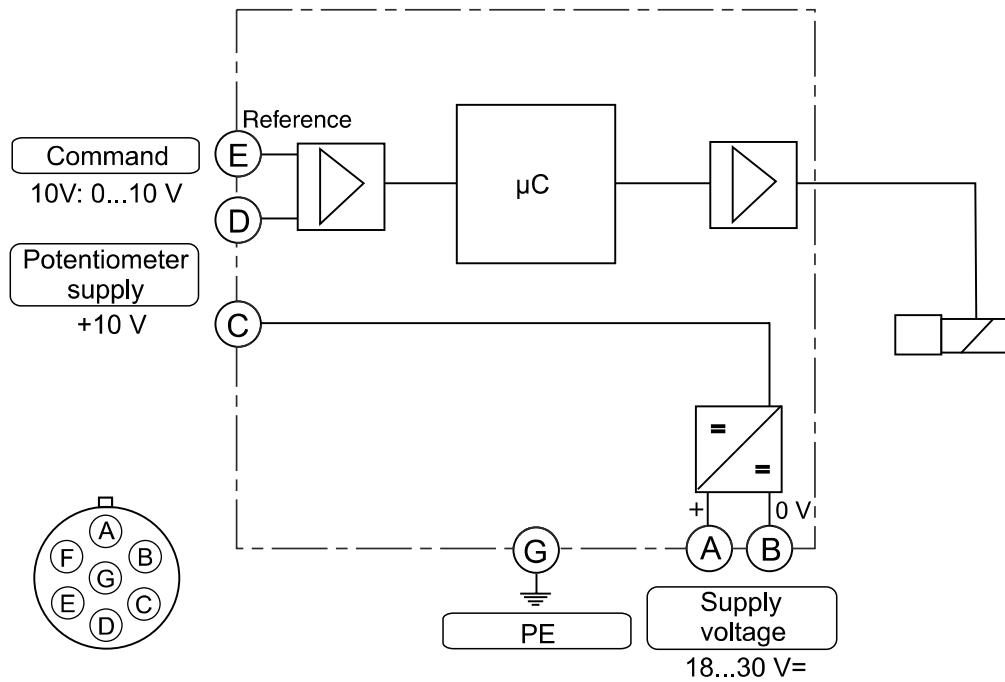

**4**

**Code 4MA**

**6 + PE acc. EN 175201-804**

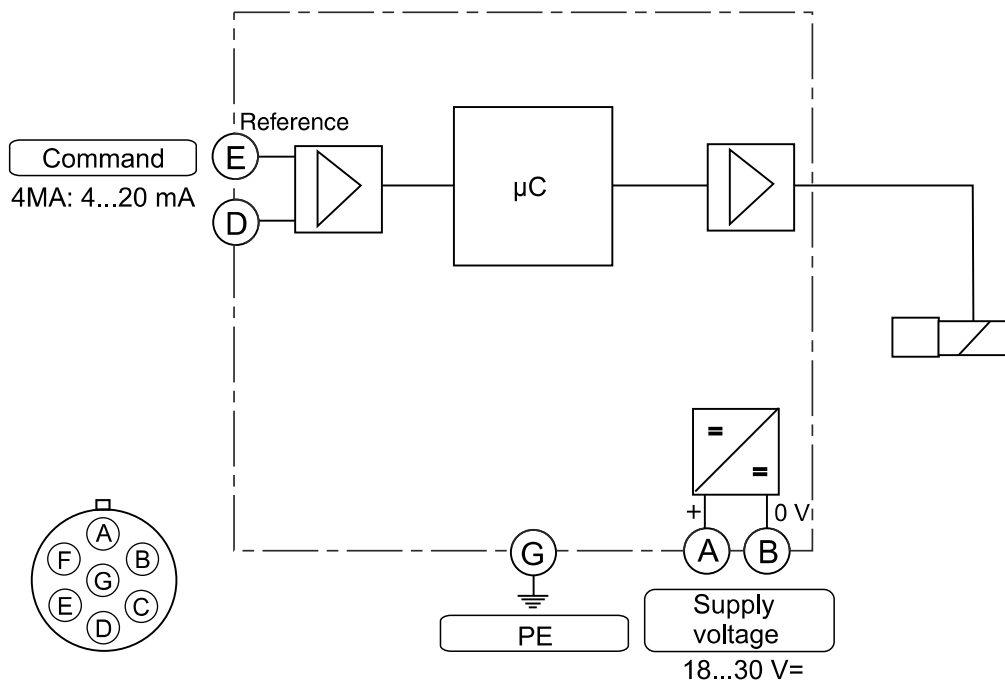

**ProPxD interface program**

The ProPxD software permits comfortable parameter setting for the module electronics. Via the clearly arranged entry mask the parameters can be noticed and modified. Storage of complete parameter sets is possible as well as printout or record as a text file for further documentation. Stored parameter sets may be loaded anytime and transmitted to other valves. Inside the electronics a non-volatile memory stores the data with the option for recal-ling or modification.

The PC software can be downloaded free of charge at [www.parker.com/isde](http://www.parker.com/isde) – see page “Support“ or directly at [www.parker.com/propxd](http://www.parker.com/propxd).

**Features**

- Comfortable editing of all parameters
- Depiction and documentation of parameter sets
- Storage and loading of optimized parameter adjust-ments
- Executable with all actual Windows® operating systems from Windows® XP upwards
- Plain communication between PC and electronics via serial interface RS232C

**The parametrizing cable may be ordered under item no. 40982923.**

4

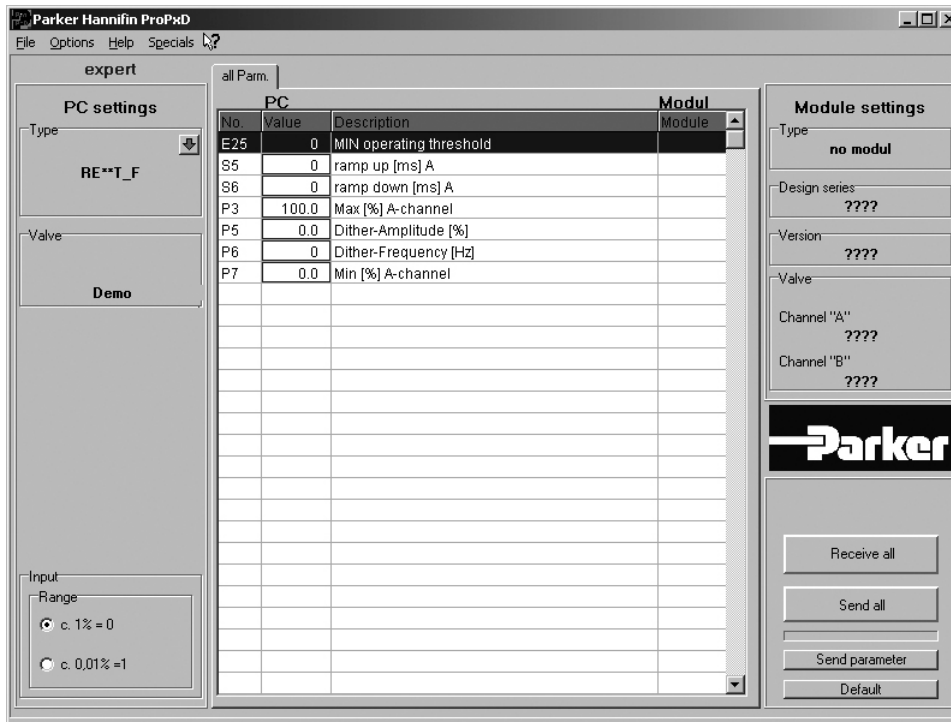

**R4V**

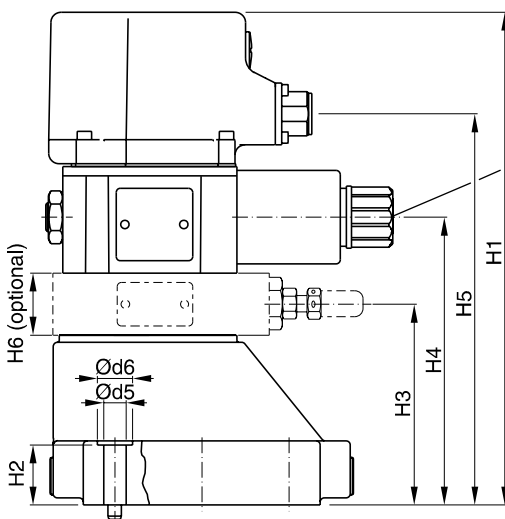
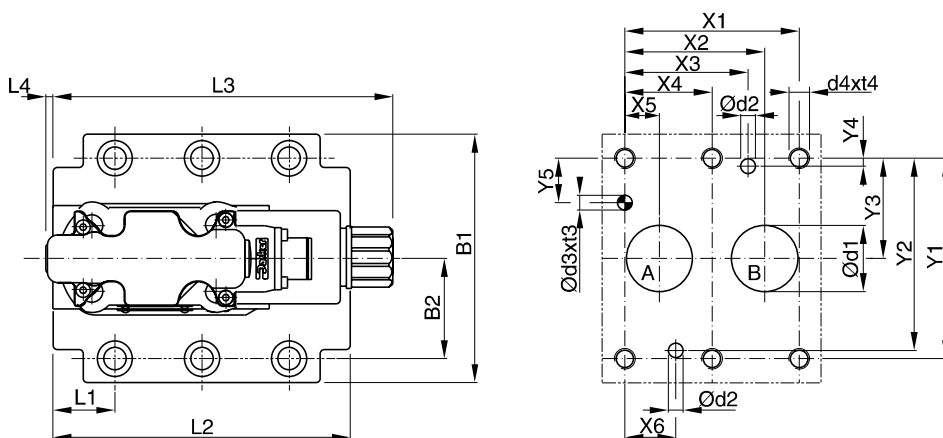

**Important:**  
On initial start up and  
after long shut down periods  
bleed air from this plug.

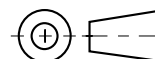

NG	ISO-code	x1	x2	x3	x4	x5	x6	x7	y1	y2	y3	y4	y5	y6
10	6264-06-07-*-97	42.9	35.8	21.5	–	7.2	21.5	0	66.7	58.8	33.4	7.9	14.3	–
25	6264-08-11-*-97	60.3	49.2	39.7	–	11.1	20.6	0	79.4	73	39.7	6.4	15.9	–
32	6264-10-15-*-97	84.2	67.5	59.5	42.1	16.7	24.6	0	96.8	92.8	48.4	3.8	21.4	–

Tolerance at X and Y pin holes and screw holes ±0.1, at port holes ±0.2.

NG	ISO-code	B1	B2	H1	H2	H3	H4	H5	H6	L1	L2	L3	L4	L5	L6
10	6264-06-07-*-97	87.3	33.35	204.7	21	62	103	148.2	32	25	90.8	164.2	4.5	–	–
25	6264-08-11-*-97	105	39.7	229.2	29	86.5	127.5	172.7	32	30.9	123	164.2	4.5	–	–
32	6264-10-15-*-97	120	48.4	241.7	30	99	140	185.2	32	29.8	143.5	164.2	4.5	–	–

NG	ISO-code	d1max	d2max	d3	t3	d4	t4	d5	d6	Subplate <sup>1)</sup>
10	6264-06-07-*-97	15	7	7.1	8	M10	16	10.8	17	SPP 3M6B 910
25	6264-08-11-*-97	23.4	7.1	7.1	8	M10	18	10.8	17	SPP 6M8B 910
32	6264-10-15-*-97	32	7.1	7.1	8	M10	20	10.8	17	SPP 10M12B 910

NG	Bolt kit			Kit		Surface finish
				NBR	FPM	
10	BK505	4x M10x35 ISO 4762-12.9	63 Nm ±15 %	S26-58507-0 <sup>2)</sup>	S26-58507-5 <sup>2)</sup>	
25	BK485	4x M10x45 ISO 4762-12.9	63 Nm ±15 %	S26-58475-0 <sup>2)</sup>	S26-58475-5 <sup>2)</sup>	
32	BK506	6x M10x45 ISO 4762-12.9	63 Nm ±15 %	S26-58508-0 <sup>2)</sup>	S26-58508-5 <sup>2)</sup>	
Prop. section P2				S26-58473-0	S26-58473-5	

<sup>1)</sup> Details see chapter 12, series SPP.

<sup>2)</sup> Please combine seal kit of one size with seal kit of Prop. section P2 for complete seal kit.

Dimensions

R6V

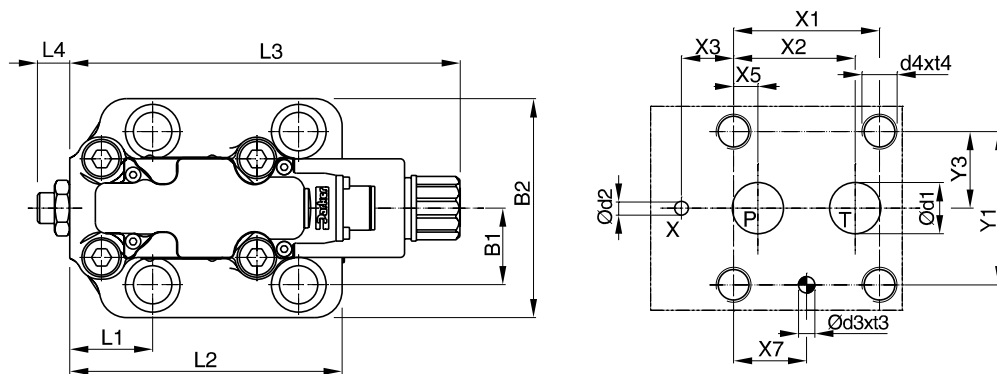

Important:  
On initial start up and  
after long shut down periods  
bleed air from this plug.

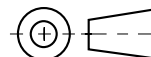
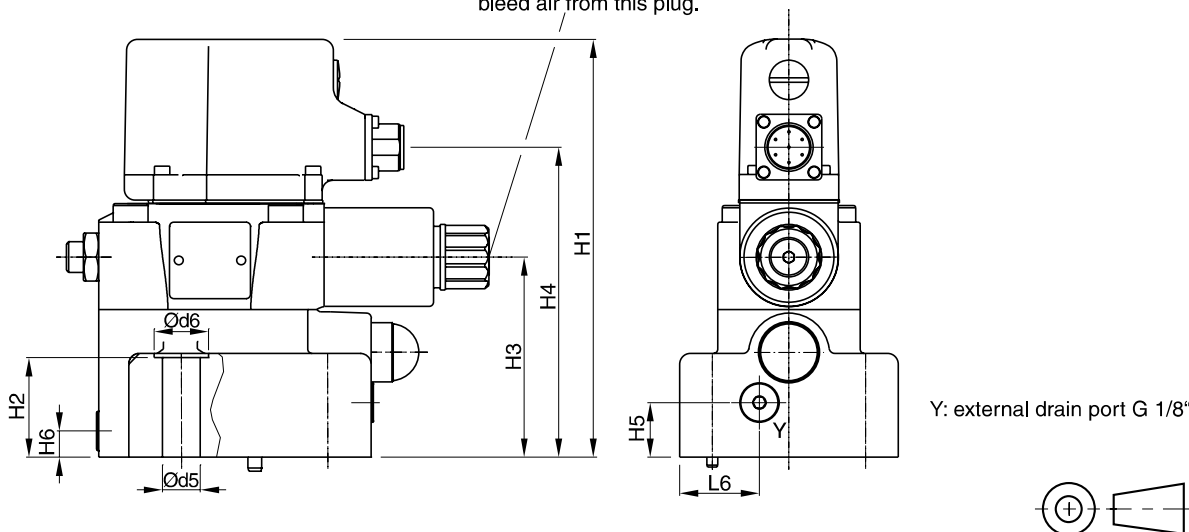



NG	ISO-code	x1	x2	x3	x4	x5	x6	x7	y1	y2	y3	y4	y5	y6
10	6264-06-09-*-97	53.8	47.5	0	-	22.1	-	22.1	53.8	-	26.9	-	-	-
25	6264-08-13-*-97	66.7	55.6	23.8	-	11.1	-	33.4	70	-	35	-	-	-
32	6264-10-17-*-97	88.9	76.2	31.8	-	12.7	-	44.5	82.6	-	41.3	-	-	-

Tolerance at X and Y pin holes and screw holes ±0.1, at port holes ±0.2.

NG	ISO-code	B1	B2	H1	H2	H3	H4	H5	H6	L1	L2	L3	L4	L5	L6
10	6264-06-09-*-97	80	26.9	187.2	27	88	138.2	20.5	25	52	117	182.3	14.4	-	29.5
25	6264-08-13-*-97	100	35	190.7	46.5	91.5	141.7	25	12	37.9	124.5	182.3	14.4	-	36.5
32	6264-10-17-*-97	120	41.3	197.7	51.3	98.5	148.7	26.5	13.5	44.3	153	182.3	14.4	-	46.5

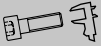
NG	ISO-code	d1max	d2max	d3	t3	d4	t4	d5	d6	Subplate <sup>1)</sup>
10	6264-06-09-*-97	14.7	4.8	7.5	10	M12	20	13.5	20	SPP 3R6B 910
25	6264-08-13-*-97	23.4	6.3	7.5	10	M16	27	17.5	25	SPP 6R10B 910
32	6264-10-17-*-97	32	6.3	7.5	10	M18	28	20	30	SPP 10R12B 910

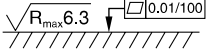
NG	Bolt kit			Kit		Surface finish
				NBR	FPM	
10	BK494	4x M12x45 ISO 4762-12.9	108 Nm ±15 %	S26-98589-0	S26-98589-5	
25	BK366	4x M16x70 ISO 4762-12.9	264 Nm ±15 %	S26-96396-0	S26-96396-5	
32	BK507	4x M18x75 ISO 4762-12.9	398 Nm ±15 %	S26-96392-0	S26-96392-5	

<sup>1)</sup> Details see chapter 12, series SPP.

4

Pilot operated relief valve with proportional adjustment. Series VBY\*K is a pilot operated pressure valve with external drain. Because of the high pressure capability of the outlet port the VBY can be used as sequence valve. In this case the external drain port Y has to be used.

The optimum performance can be achieved in combination with the digital amplifier module PCD00A-400.

**Features**

- Proportional adjustment
- Subplate mounting acc. to ISO 5781
- External drain
- Main stage spool type valve
- Pilot stage seated type valve



VBY\*K06

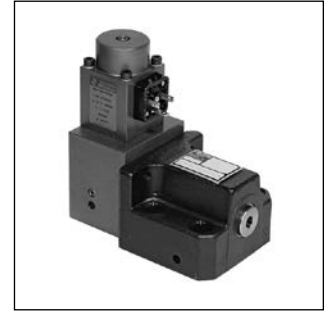

VBY\*K10

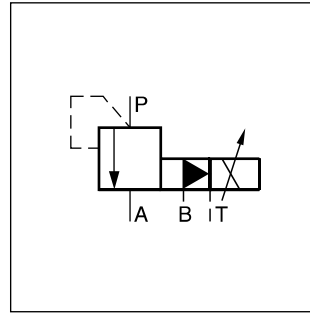

VBY\*K06

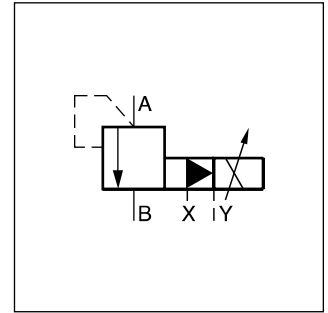

VBY\*K10

**4**

**VBY\*K06**

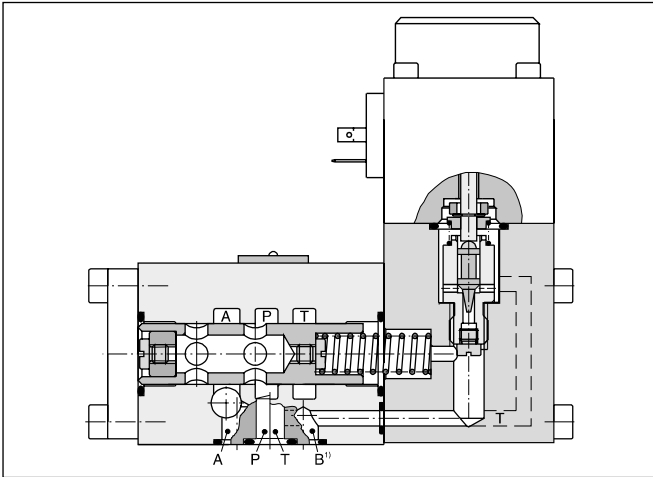

**VBY\*K10**

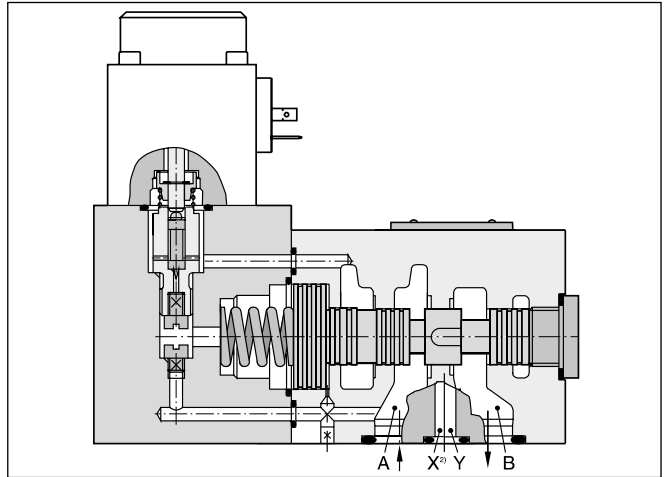

**Ordering code**

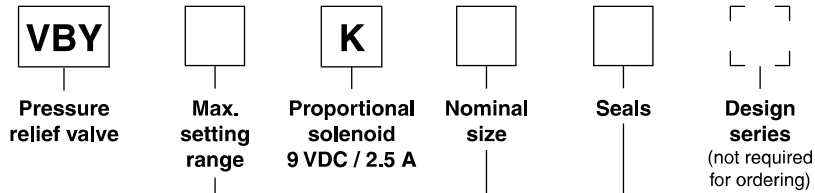

Code	Max. setting range
<b>064</b>	<b>64 bar</b>
100	100 bar
<b>160</b>	<b>160 bar</b>
210	210 bar
315	315 bar

Code	Seals
<b>N</b>	<b>NBR</b>
V	FPM

Code	Nominal size
<b>06</b>	<b>NG06</b>
<b>10</b>	<b>NG10</b>

**Bold letters =  
Short-term availability**

<sup>1)</sup> Port B for remote control, otherwise to be blocked.  
<sup>2)</sup> Port X for remote control, otherwise to be blocked.

**Technical data**

General			
Design	Proportional pressure relief valve		
Nominal size	NG06		NG10
Interface	Subplate mounting according to ISO 5781		
Actuation	Proportional solenoid		
Mounting position	unrestricted		
Ambient temperature	[°C]	-20 ... +60	
MTTF <sub>D</sub> value	[years]	75	
Weight	[kg]	2.4	4.5
Hydraulics			
Max. operating pressure	[bar]	P, A: 315, Port B blocked, Port T depressurized	A, B: 315, Port Y blocked, Port Y depressurized
Nominal flow	[l/min]	40	160
Adjustment range	[bar]	up to 64, 100, 160, 210, 315	
Fluid	Hydraulic oil according to DIN 51524		
Viscosity	permitted	[cSt] / [mm <sup>2</sup> /s]	20 ... 400
	recommended	[cSt] / [mm <sup>2</sup> /s]	30 ... 80
Fluid temperature	[°C]	-20...+70 (NBR: -25...+70)	
Filtration	ISO 4406 (1999); 18/16/13		
Linearity	[%]	±3.5 at > 15 % pnom.	
Repeatability	[%]	<±2	
Hysteresis	[%]	<3	
Response time	[ms]	<150	<200
Electrical			
Duty ratio	[%]	100 ED	
Protection class	IP65 at EN 60529 (with correctly mounted plug-in connector)		
Nominal voltage	[VDC]	9	
Max. current	[A]	2.7	
Nom. current	[A]	2.5	
Ambient temperature	[°C]	-20...+70	
Coil resistance	[Ohm]	2.1 at 20 °C	
Solenoid connection	Connector as per EN 175301-803		
Power amplifier	PCD00A-400		

4

**Characteristic pressure curves for NG06  $p = f(U_{set})$**

**Setting range max. 64 bar**

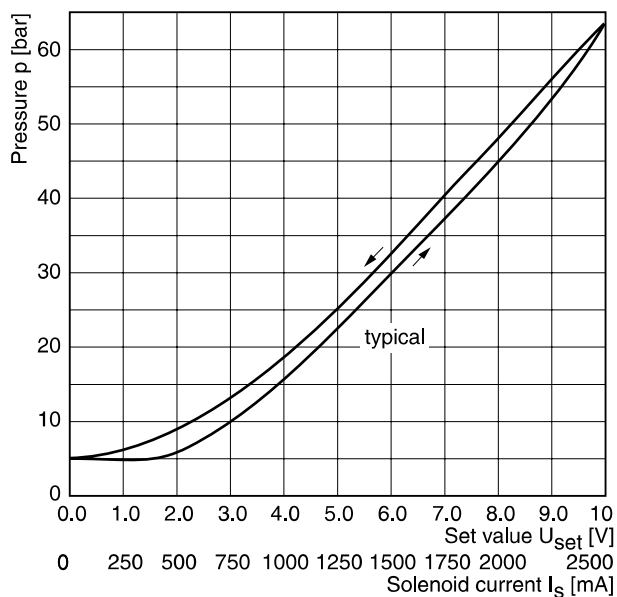

**Setting range max. 210 bar**

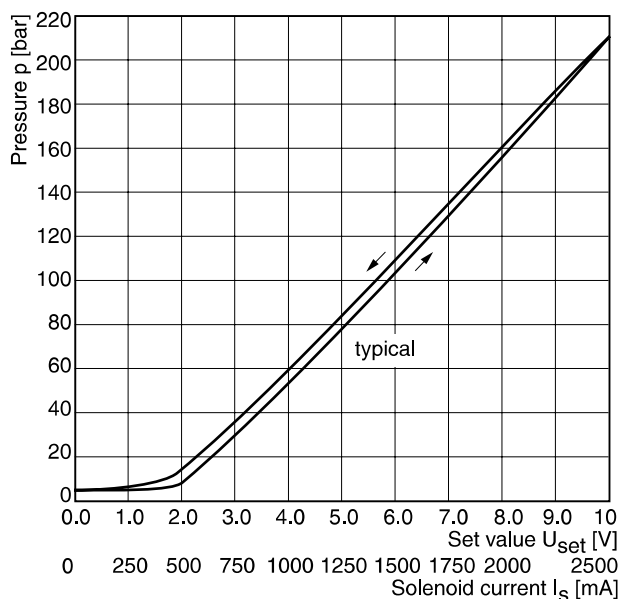

All characteristic curves measured with HLP46 at 50 °C.



**NG06 p/Q characteristics**

**Setting range max. 64 bar**

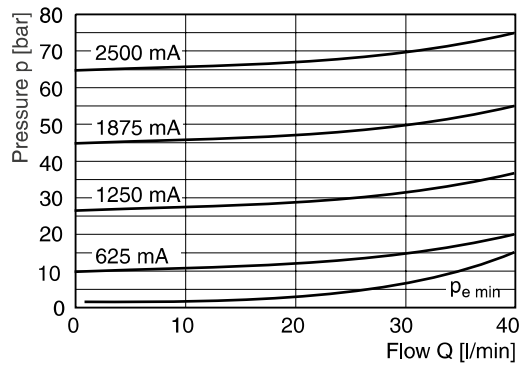

**Setting range max. 100 bar**

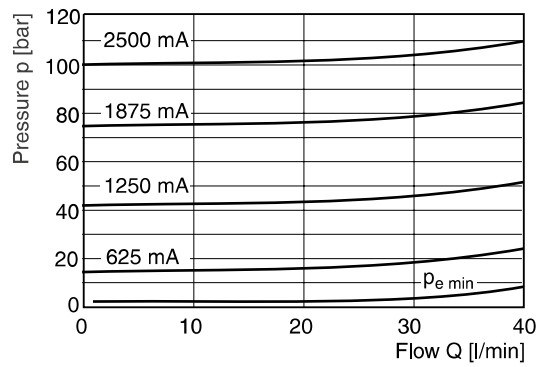

**Setting range max. 160 bar**

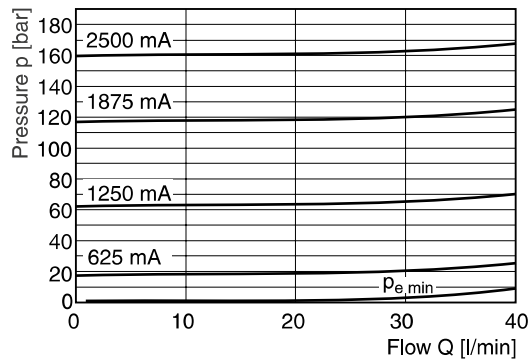

**Setting range max. 210 bar**

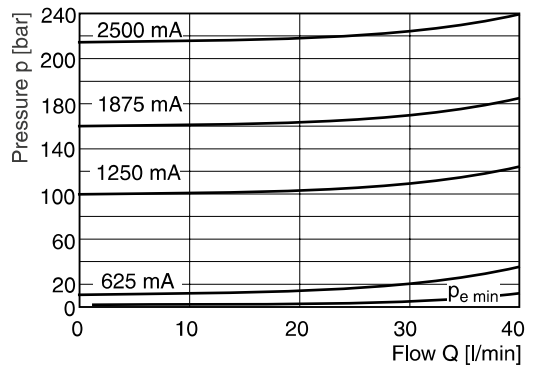

**Setting range max. 315 bar**

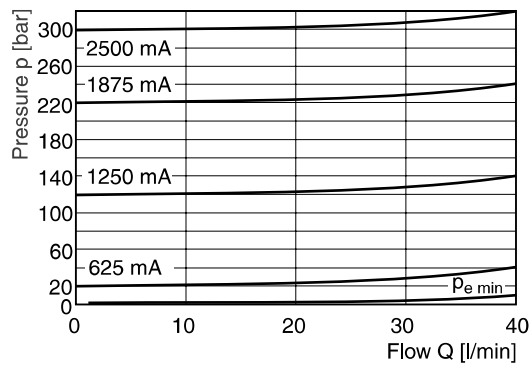

All characteristic curves measured with HLP46 at 50 °C.

**4**

**NG06 step response signal, setting range max. 210 bar**

**4**

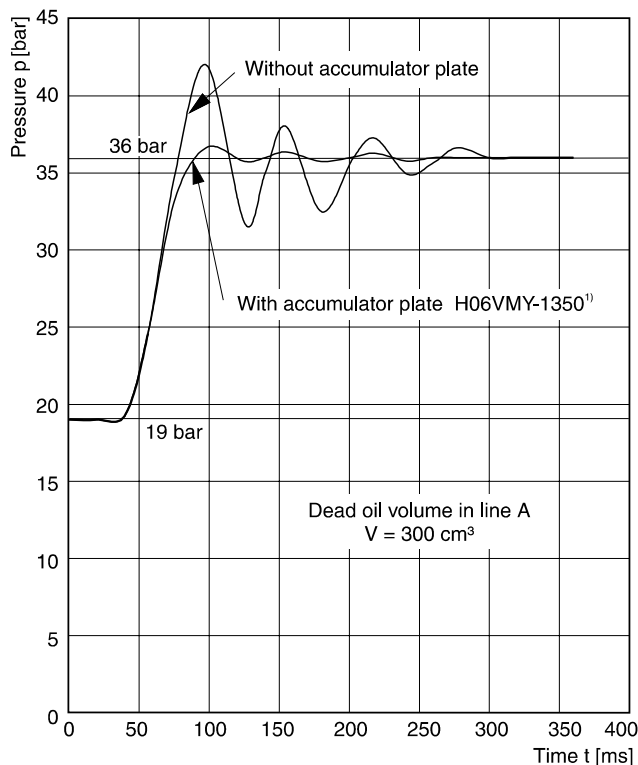
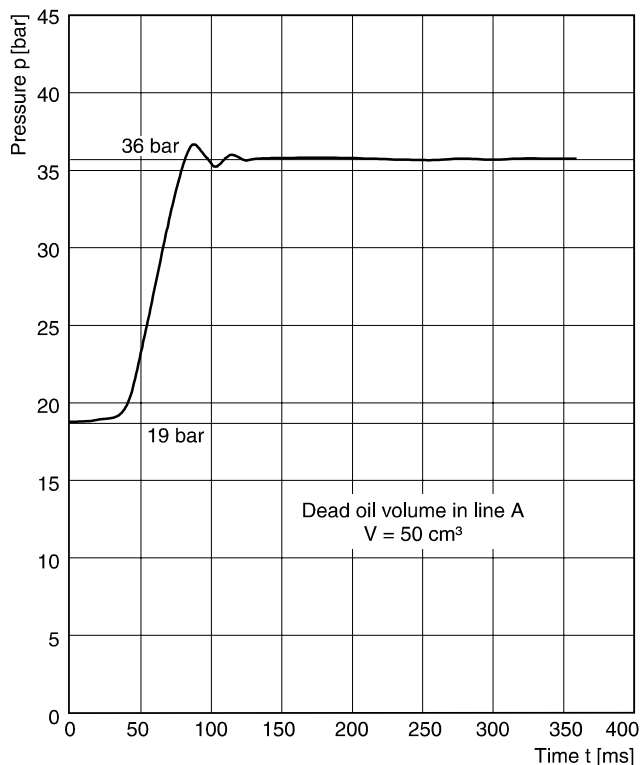

**NG10 p/Q characteristics**

**Setting range max. 64 bar**

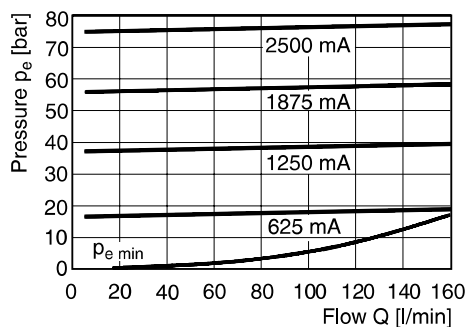

**Setting range max. 100 bar**

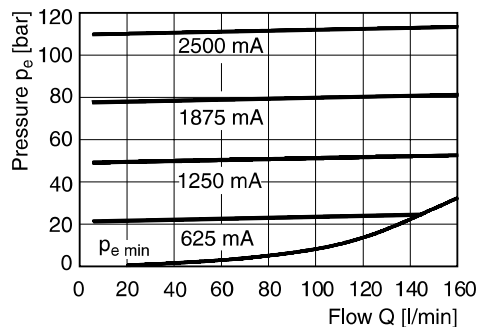

**Setting range max. 160 bar**

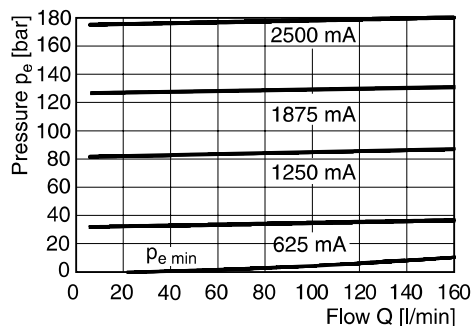

**Setting range max. 210 bar**

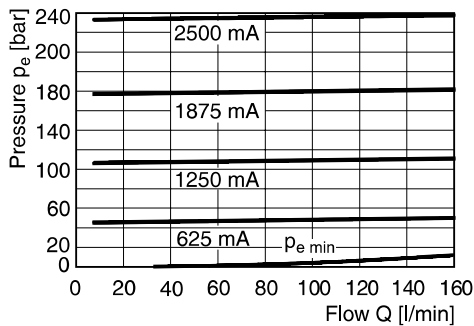

All characteristic curves measured with HLP46 at 50 °C.

<sup>1)</sup> See series VMY for details.

**NG06**

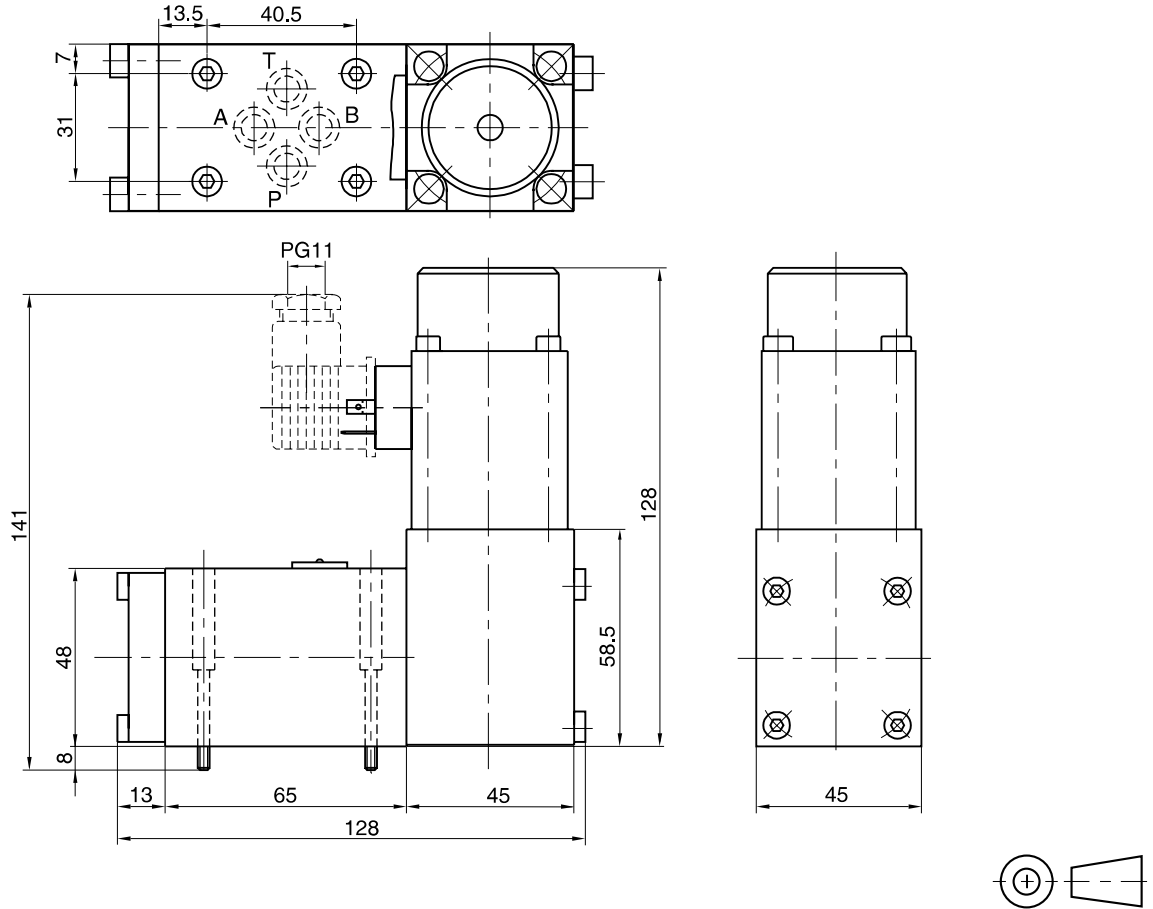

**4**

Surface finish	Bolt kit			Kit	
				NBR	FPM
	BK375	4x M5x30 ISO 4762-12.9	7.6 Nm ±15 %	SK-VMY-L06-N	SK-VMY-L06-V

**Mounting pattern ISO 5781-03-04-0-00**

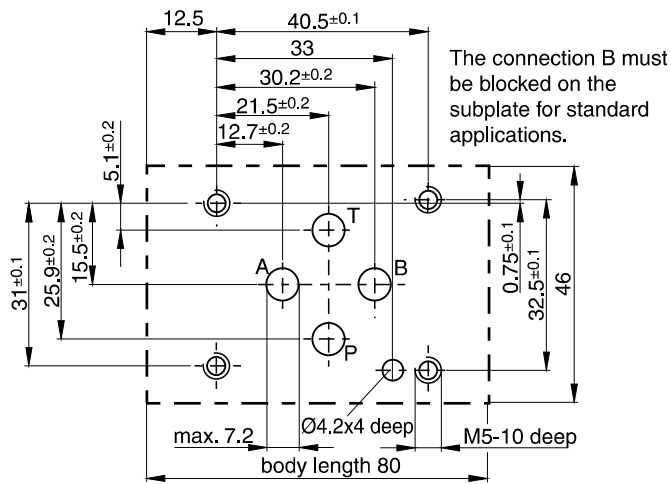



Dimensions

NG10

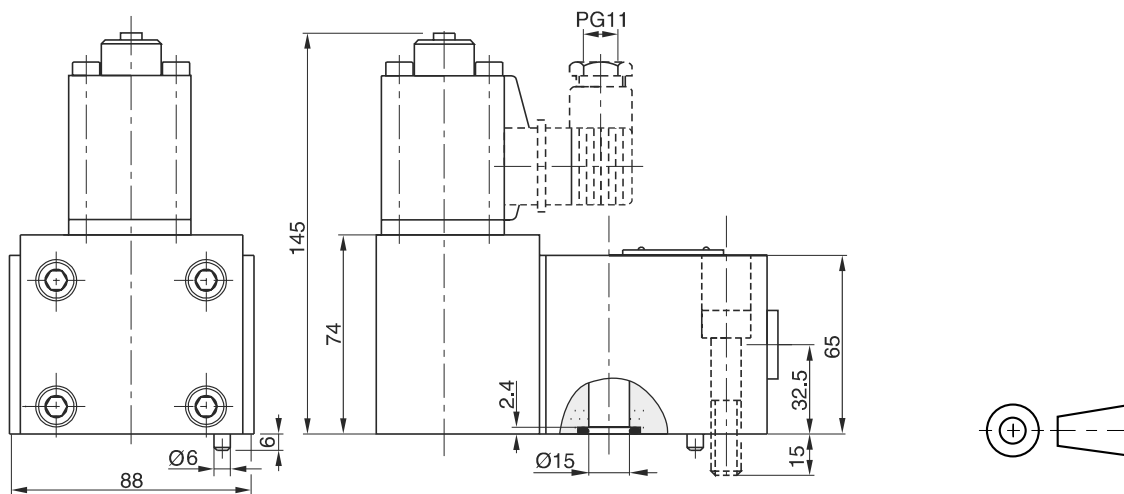
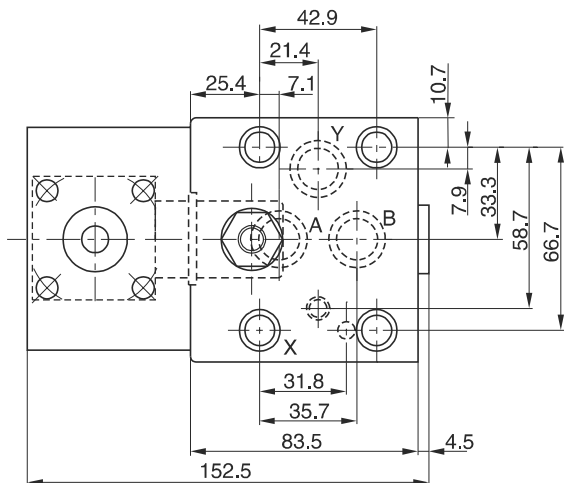
4

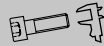

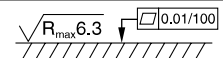
Surface finish	Bolt kit			 Kit FPM
	BK389	4x M10x50 ISO 4762-12.9	63 Nm ±15 %	SK-VB/VM-A10V

Mounting pattern ISO 5781-06-07-0-00<sup>1)</sup>

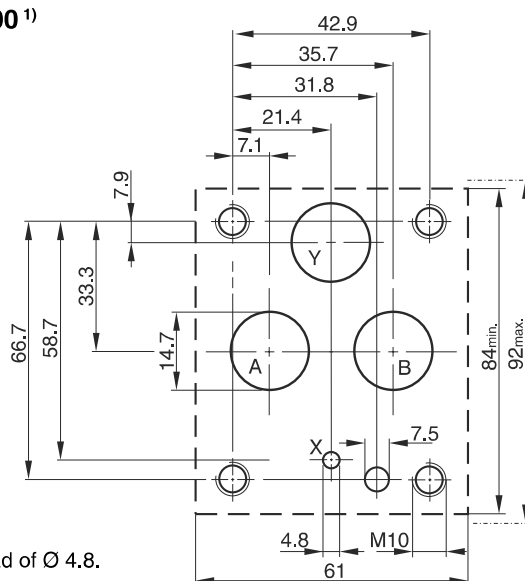

<sup>1)</sup> Deviating from ISO the Y port has Ø 14.7 instead of Ø 4.8.

**Characteristics**

**Unloading Valve  
Series R4U**

Subplate mounted unloading valves series R4U are used to unload a circuit at low pressure. The mechanically adjustable pressure signal to unload the main stage has to be applied to port X. The pressure differential between opening and closing is nominal 15 or 28 % of the setting pressure:

28 % for pressure stages 105 and 210 bar

15 % for pressure stage 350 bar

Typical applications are unloading of pumps in an accumulator circuit or unloading of the low pressure stage of a double pump.

The R4U is available with an electrical vent valve for unpressurized circulation.

**Features**

- Pilot operated unloading valve
- Interface
  - subplate mounting to ISO 5781
- 3 pressure stages
- 2 vent valve functions
- 3 adjustment modes:
  - hand knob
  - acorn nut with lead seal
  - cylinder lock

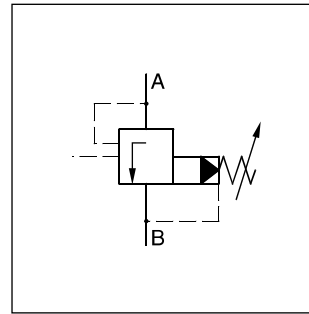

R4U

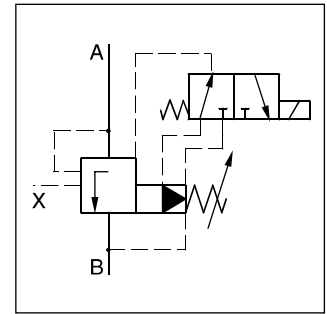

R4U with vent function

**4**

**R4U06**

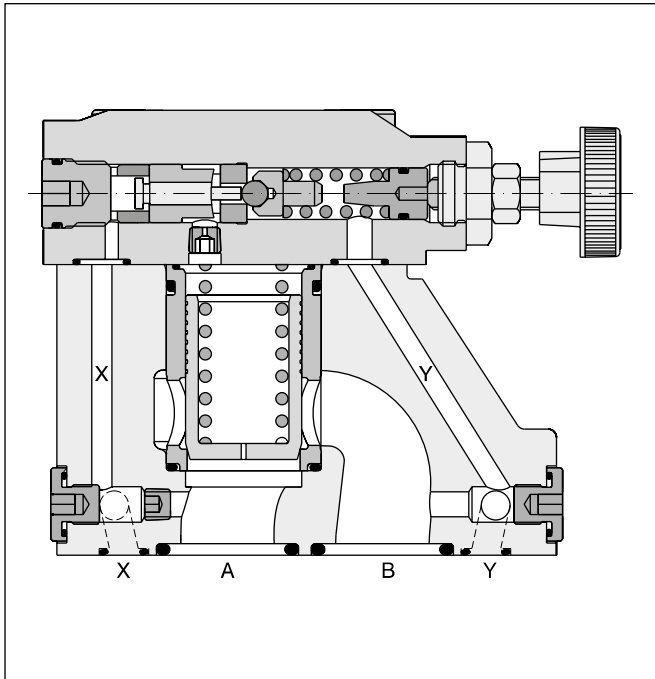

**R4U06 with vent function**

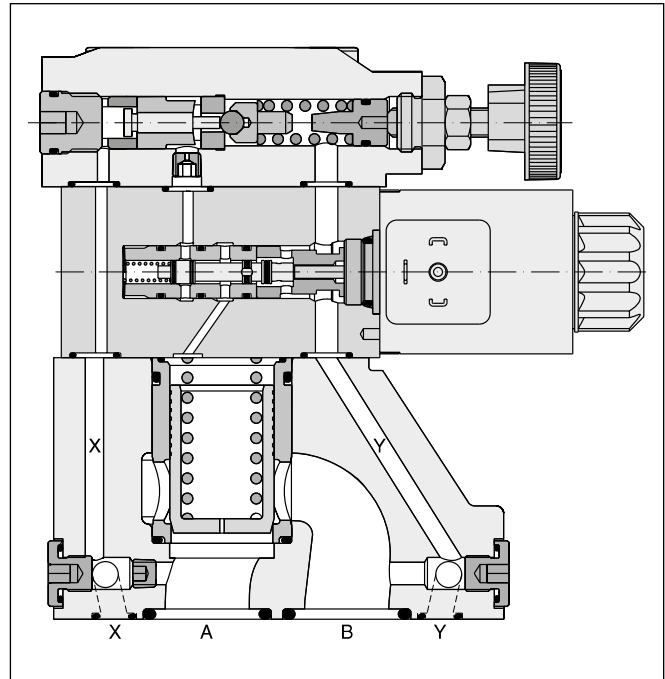

Ordering Code

R4U

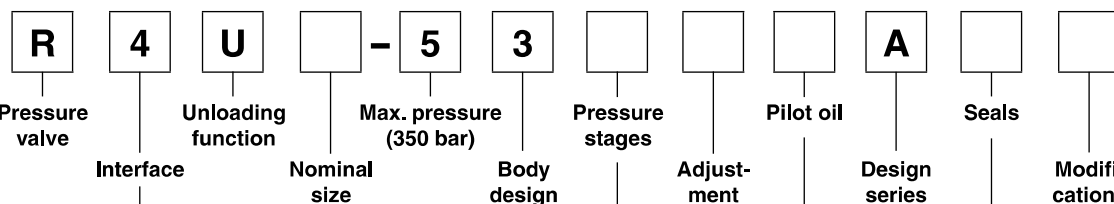

Code	Interface	
4	Subplate mounting ISO 5781	

Code	Nominal size
03	NG10
06	NG25
10	NG32

Code	Pressure stages	Pressure differential
1	up to 105 bar	28 %
3	up to 210 bar	28 %
5	up to 350 bar	15 %

Code	Seals
1	NBR
5	FPM

Pilot oil	
Code	Drain line
0	Internal
1	Ext. from subplate

Code	Adjustment
1	Hand knob 32 mm diameter (standard)
3	Acorn nut with lead seal
4	Cylinder lock

R4U with vent function

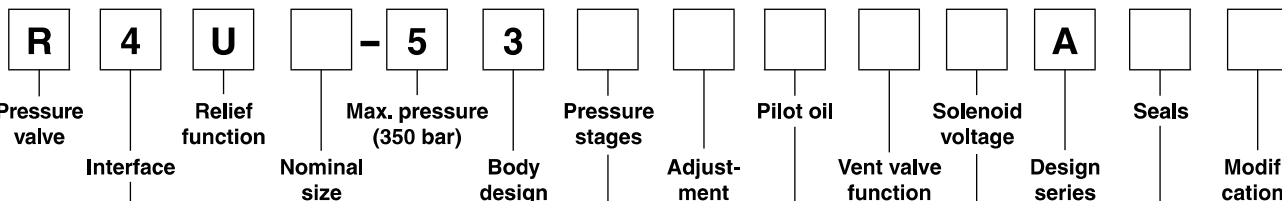

Code	Interface	
4	Subplate mounting ISO 5781	

Code	Nominal size
03	NG10
06	NG25
10	NG32

Code	Pressure stages	Pressure differential
1	up to 105 bar	28 %
3	up to 210 bar	28 %
5	up to 350 bar	15 %

Code	Adjustment
1	Hand knob (standard)
3	Acorn nut with lead seal
4	Cylinder lock

Code	Seals
1	NBR
5	FPM

Code	Voltage
G0R	12 V =
G0Q	24 V =
GAR <sup>1)</sup>	98 V =
GAG <sup>1)</sup>	205 V =
W30	110 V / 50 Hz 120 V / 60 Hz
W31	230 V / 50 Hz 240 V / 60 Hz

Code	Vent valve
09	Solenoid not activ. unpress. circulation
11	Solenoid activated unpress. circulation

Pilot oil	
Code	Drain line
0	Internal
1	Ext. from subplate

<sup>1)</sup> To be used in combination with rectifier plugs at 120 VAC resp. 230 VAC power supply.

**R4U**

<b>General</b>		<b>NG10</b>	<b>NG25</b>	<b>NG32</b>
Nominal size				
Interface	Subplate mounting acc. ISO 5781			
Mounting position	Unrestricted, horizontal mounting preferred			
Ambient temperature	[°C]	-20...+60		
MTTF <sub>D</sub> value	[years]	75		
Weight	[kg]	2.7	4.5	6.0
<b>Hydraulic</b>				
Max. operating pressure	[bar]	Ports A and X 350, Ports B and Y depressurized		
Pressure stages	[bar]	105, 210, 350		
Pressure differential		28 % (for pressure stages 105 bar and 210 bar); 15 % (for pressure stages 350 bar)		
Nominal flow	[l/min]	150	350	650
Fluid		Hydraulic oil according to DIN 51524		
Viscosity, permitted	[cSt] / [mm <sup>2</sup> /s]	20 ... 400		
recommended	[cSt] / [mm <sup>2</sup> /s]	30 ... 80		
Fluid temperature	[°C]	-20...+70 (NBR: -25...+70)		
Filtration		ISO 4406 (1999); 18/16/13		

**4**

**R4U with vent function**

<b>General</b>		<b>NG10</b>	<b>NG25</b>	<b>NG32</b>			
Nominal size							
Interface	Subplate mounting acc. ISO 5781						
Mounting position	Unrestricted, horizontal mounting preferred						
Ambient temperature	[°C]	-20...+60					
MTTF <sub>D</sub> value	[years]	75					
Weight	[kg]	4.4	6.2	7.7			
<b>Hydraulic</b>							
Max. operating pressure	[bar]	Ports A and X 350, Ports B and Y depressurized					
Pressure stages	[bar]	105, 210, 350					
Pressure differential		28 % (for pressure stages 105 bar and 210 bar); 15 % (for pressure stages 350 bar)					
Nominal flow	[l/min]	150	350	650			
Fluid		Hydraulic oil according to DIN 51524					
Viscosity, permitted	[cSt] / [mm <sup>2</sup> /s]	20 ... 400					
recommended	[cSt] / [mm <sup>2</sup> /s]	30 ... 80					
Fluid temperature	[°C]	-20...+70 (NBR: -25...+70)					
Filtration		ISO 4406 (1999); 18/16/13					
<b>Electrical (solenoid)</b>							
Duty ratio	[%]	100 ED; CAUTION: coil temperature up to 150 °C possible					
Protection class		IP65 in according with EN 60529 (with correctly mounted plug-in connector)					
	Code	G0R	G0Q	GAR	GAG	W30	W31
Supply voltage	[V]	12 V =	24 V =	98 V =	205 V =	110 V / 50 Hz 120 V / 60 Hz	230 V / 50 Hz 240 V / 60 Hz
Tolerance supply voltage	[%]	±10	±10	±10	±10	±5	±5
Current consumption	hold [A]	2.72	1.29	0.33	0.13	0.6 / 0.55	0.3 / 0.27
	in rush [A]	2.72	1.29	0.33	0.13	2.5 / 2.4	1.25 / 1.2
Power consumption	hold [W]	32.7	31	31.9	28.2	70 / 70 VA	70 / 70 VA
	in rush [W]	32.7	31	31.9	28.2	280 / 290 VA	280 / 290 VA
Solenoid connection		Connector as per EN175301-803, solenoid identification as per ISO 9461					
Wiring min.	[mm <sup>2</sup> ]	3 x 1.5 recommended					
Wiring length max.	[m]	50 recommended					

**p/Q performance curve <sup>1)</sup>**

**Minimum pressure curve**

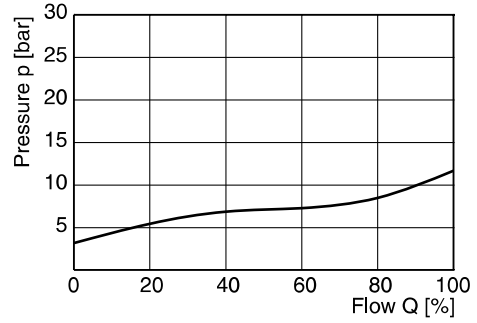
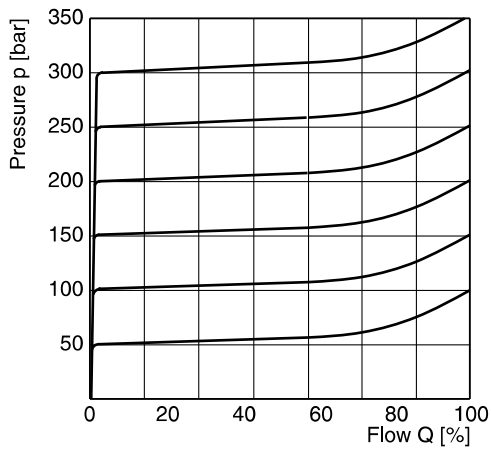

All characteristic curves measured with HLP46 at 50 °C.

<sup>1)</sup> The performance curves are measured with external drain.  
For internal drain the tank pressure has to be added to curve.



**R4U**

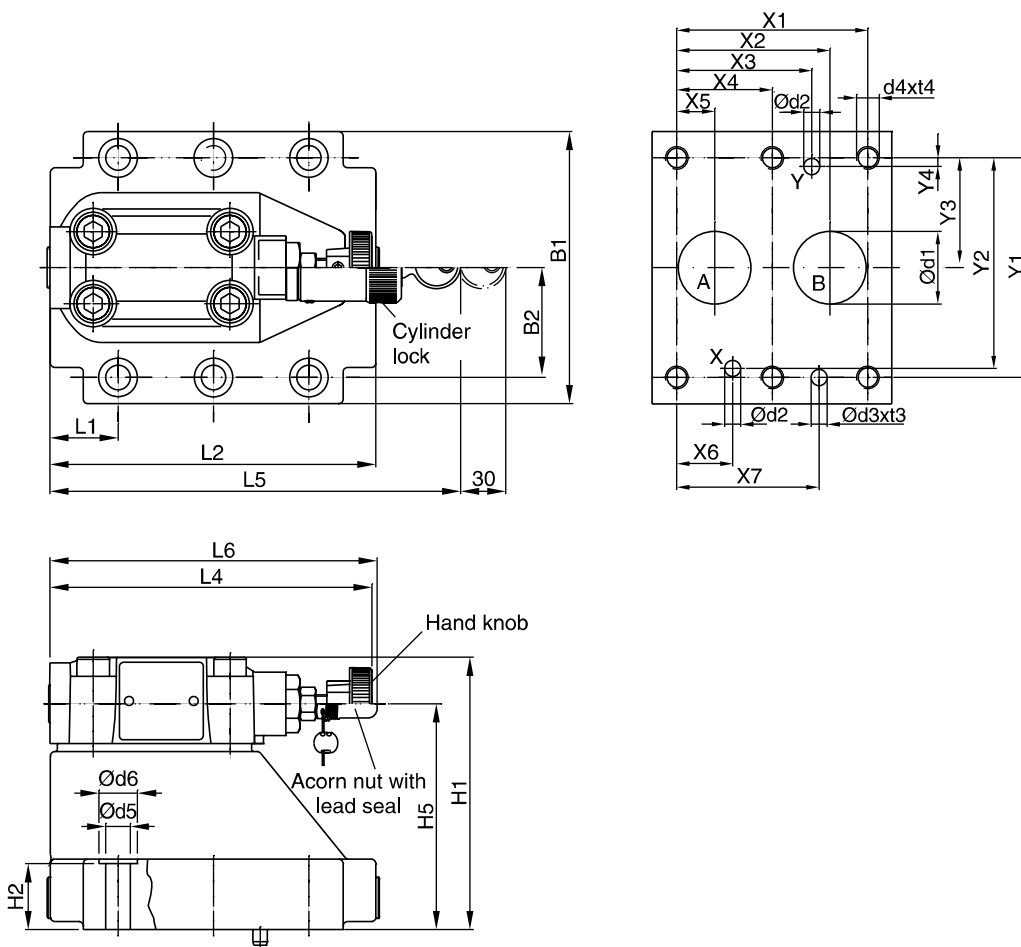



**4**

NG	ISO-code	x1	x2	x3	x4	x5	x6	x7	y1	y2	y3	y4	y5	y6
10	5781-06-07-0-00	42.9	35.8	21.5	–	7.2	21.5	31.8	66.7	58.8	33.4	7.9	–	–
25	5781-08-10-0-00	60.3	49.2	39.7	–	11.1	20.6	44.5	79.4	73	39.7	6.4	–	–
32	5781-10-13-0-00	84.2	67.5	59.5	42.1	16.7	24.6	62.7	96.8	92.8	48.4	3.8	–	–

Tolerance at X and Y pin holes and screw holes  $\pm 0.1$ , at port holes  $\pm 0.2$ .

NG	ISO-code	B1	B2	H1	H2	H3	H4	H5	H6	L1	L2	L3	L4	L5	L6
10	5781-06-07-0-00	87.3	33.35	83	21	–	–	62.5	–	25	90.8	–	143	181	144.8
25	5781-08-10-0-00	105	39.7	107.5	29	–	–	87	–	30.9	123	–	143	181	144.8
32	5781-10-13-0-00	120	48.4	120	30	–	–	99.5	–	29.8	143.5	–	143	181	144.8

NG	ISO-code	d1max	d2max	d3	t3	d4	t4	d5	d6	Subplate <sup>1)</sup>
10	5781-06-07-0-00	15	7	7.1	8	M10	16	10.8	17	SPP 3M6B 910
25	5781-08-10-0-00	23.4	7.1	7.1	8	M10	18	10.8	17	SPP 6M8B 910
32	5781-10-13-0-00	32	7.1	7.1	8	M10	20	10.8	17	SPP 10M12B 910

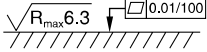
NG	Bolt kit			Kit		Surface finish
				NBR	FPM	
10	BK505	4x M10x35 ISO 4762-12.9	63 Nm $\pm 15$ %	S26-58507-0	S26-58507-5	
25	BK485	4x M10x45 ISO 4762-12.9	63 Nm $\pm 15$ %	S26-58475-0	S26-58475-5	
32	BK506	6x M10x45 ISO 4762-12.9	63 Nm $\pm 15$ %	S26-58508-0	S26-58508-5	

<sup>1)</sup> Details see chapter 12, series SPP.

Dimensions

R4U with vent function

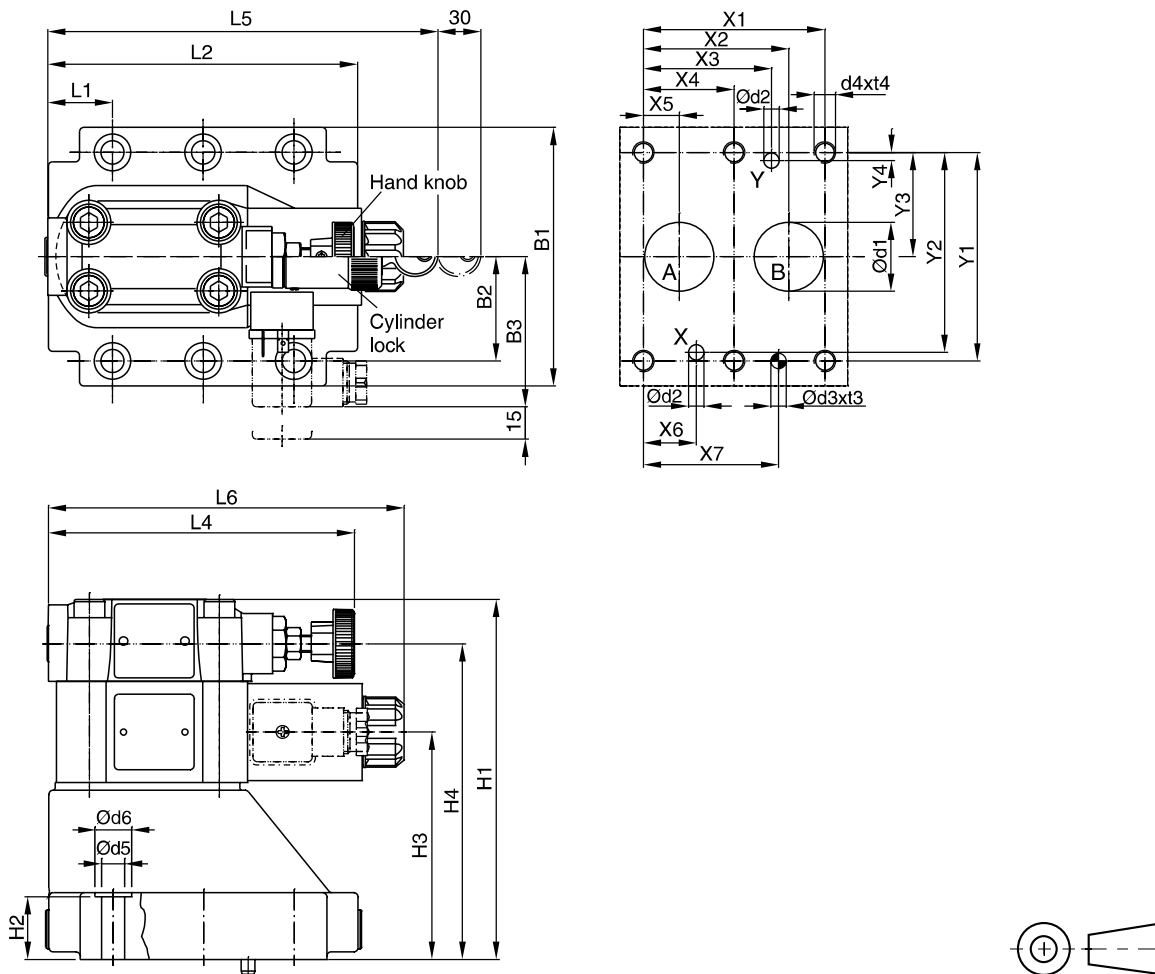

4

NG	ISO-code	x1	x2	x3	x4	x5	x6	x7	y1	y2	y3	y4	y5	y6
10	5781-06-07-0-00	42.9	35.8	21.5	–	7.2	21.5	31.8	66.7	58.8	33.4	7.9	–	–
25	5781-08-10-0-00	60.3	49.2	39.7	–	11.1	20.6	44.5	79.4	73	39.7	6.4	–	–
32	5781-10-13-0-00	84.2	67.5	59.5	42.1	16.7	24.6	62.7	96.8	92.8	48.4	3.8	–	–

Tolerance at X and Y pin holes and screw holes ±0.1, at port holes ±0.2.

NG	ISO-code	B1	B2	B3	H1	H2	H3	H4	H5	H6	L1	L2	L3	L4	L5	L6
10	5781-06-07-0-00	87.3	33.35	70	130	21	68.5	109.5	–	–	25	90.8	–	143	181	165.6
25	5781-08-10-0-00	105	39.7	70	154.5	29	93	134	–	–	30.9	123	–	143	181	165.6
32	5781-10-13-0-00	120	48.4	70	167	30	105.5	146.5	–	–	29.8	143.5	–	143	181	165.6

NG	ISO-code	d1max	d2max	d3	t3	d4	t4	d5	d6	Subplate <sup>1)</sup>
10	5781-06-07-0-00	15	7	7.1	8	M10	16	10.8	17	SPP 3M6B 910
25	5781-08-10-0-00	23.4	7.1	7.1	8	M10	18	10.8	17	SPP 6M8B 910
32	5781-10-13-0-00	32	7.1	7.1	8	M10	20	10.8	17	SPP 10M12B 910

NG	Bolt kit			Kit		Surface finish
				NBR	FPM	
10	BK505	4x M10x35 ISO 4762-12.9	63 Nm ±15 %	S26-58507-0 <sup>2)</sup>	S26-58507-5 <sup>2)</sup>	
25	BK485	4x M10x45 ISO 4762-12.9	63 Nm ±15 %	S26-58475-0 <sup>2)</sup>	S26-58475-5 <sup>2)</sup>	
32	BK506	6x M10x45 ISO 4762-12.9	63 Nm ±15 %	S26-58508-0 <sup>2)</sup>	S26-58508-5 <sup>2)</sup>	
VV01, AC solenoid				S26-35237-0	S26-35237-5	
VV01, DC solenoid				S56-40609-0	S56-40609-5	

<sup>1)</sup> Details see chapter 12, series SPP.

<sup>2)</sup> Please combine seal kit of one size with seal kit of VV01 DC / AC solenoid for complete seal kit.

Subplate mounted sequence valves series R4S enable a hydraulic system to operate in a pressure sequence. When the system pressure reaches the setting pressure the valve opens and permits flow to the secondary sub-system.

**Features**

- Pilot operated sequence valve
- Subplate mounting acc. to ISO 5781
- 3 pressure stages
- 3 adjustment modes:
  - hand knob
  - acorn nut with lead seal
  - cylinder lock

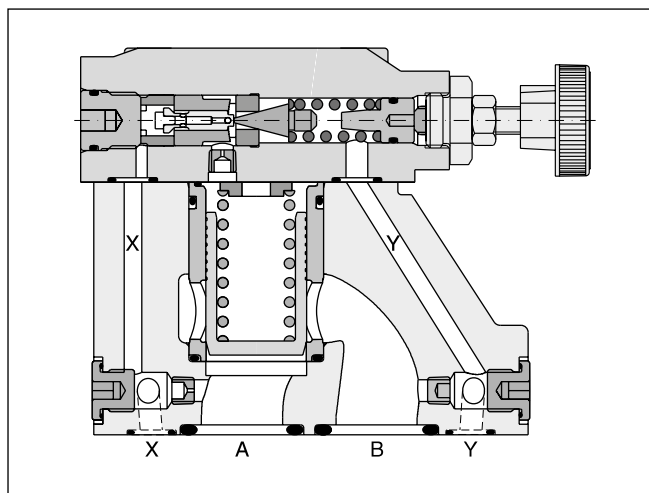
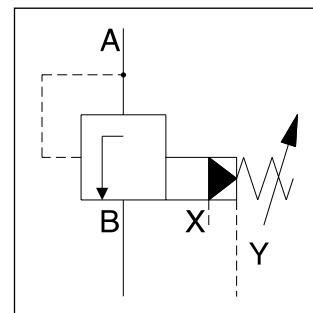

**4**

**Ordering code**

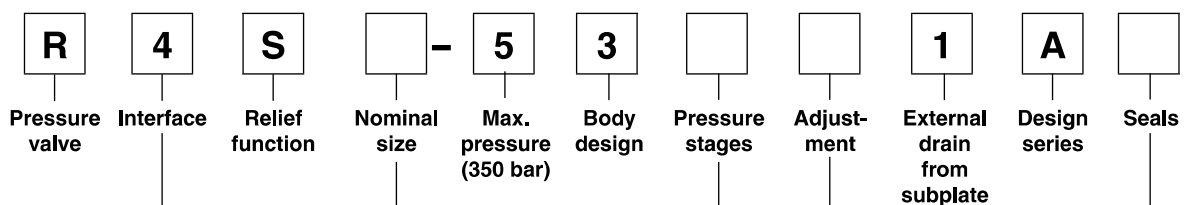

Code	Interface
4	Subplate mounting ISO 5781 

Code	Nominal size
03	NG10
06	NG25
10	NG32

Code	Pressure stages
1	up to 105 bar
3	up to 210 bar
5	up to 350 bar

Code	Seals
1	NBR
5	FPM

Code	Adjustment
1	Hand knob 32 mm diameter (standard)
3	Acorn nut with lead seal
4	Cylinder lock

**Technical Data / Characteristics Curve**

**Technical data**

General				
Nominal size		<b>NG10</b>	<b>NG25</b>	<b>NG32</b>
Interface	Subplate mounting acc. ISO 5781			
Mounting position	Unrestricted, horizontal mounting preferred			
Ambient temperature	[°C]	-20...+60		
MTTF <sub>D</sub> value	[years]	75		
Weight	[kg]	2.7	4.5	6.0
Hydraulic				
Max. operating pressure	[bar]	Ports A, B and X 350, port Y depressurized		
Pressure stages	[bar]	105, 210, 350		
Nominal flow	[l/min]	150	350	650
Fluid	Hydraulic oil according to DIN 51524			
Viscosity, permitted	[cSt] / [mm <sup>2</sup> /s]	20 ... 400		
		30 ... 80		
Fluid temperature	[°C]	-20...+70 (NBR: -25...+70)		
Filtration	ISO 4406 (1999); 18/16/13			

4

**Typical pressure characteristics at closing point**

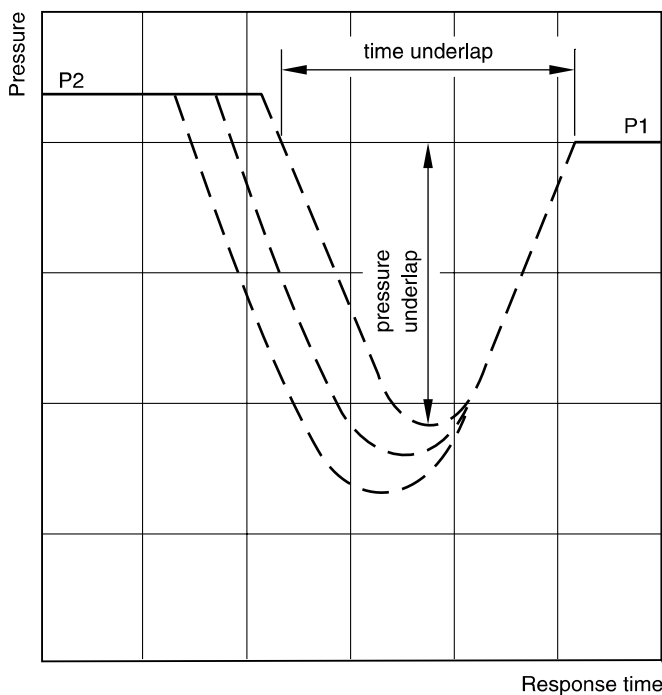

P1 = setting pressure  
P2 = operating pressure

Time and pressure underlap depend on the characteristics of the specific system.

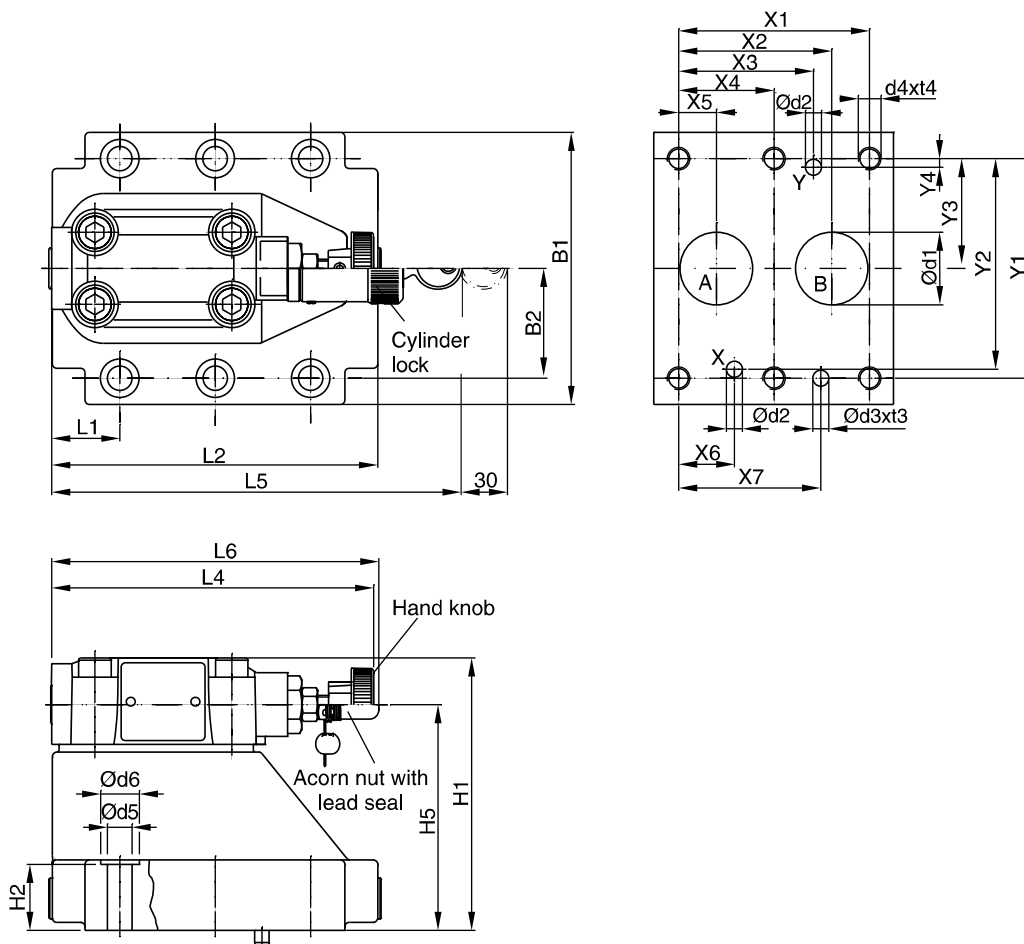

**4**

NG	ISO-code	x1	x2	x3	x4	x5	x6	x7	y1	y2	y3	y4	y5	y6
10	5781-06-07-0-00	42.9	35.8	21.5	–	7.2	21.5	31.8	66.7	58.8	33.4	7.9	–	–
25	5781-08-10-0-00	60.3	49.2	39.7	–	11.1	20.6	44.5	79.4	73	39.7	6.4	–	–
32	5781-10-13-0-00	84.2	67.5	59.5	42.1	16.7	24.6	62.7	96.8	92.8	48.4	3.8	–	–

Tolerance at X and Y pin holes and screw holes ±0.1, at port holes ±0.2.

NG	ISO-code	B1	B2	H1	H2	H3	H4	H5	H6	L1	L2	L3	L4	L5	L6
10	5781-06-07-0-00	87.3	33.35	83	21	–	–	62.5	–	25	90.8	–	143	181	144.8
25	5781-08-10-0-00	105	39.7	107.5	29	–	–	87	–	30.9	123	–	143	181	144.8
32	5781-10-13-0-00	120	48.4	120	30	–	–	99.5	–	29.8	143.5	–	143	181	144.8

NG	ISO-code	d1max	d2max	d3	t3	d4	t4	d5	d6	Subplate <sup>1)</sup>
10	5781-06-07-0-00	15	7	7.1	8	M10	16	10.8	17	SPP 3M6B 910
25	5781-08-10-0-00	23.4	7.1	7.1	8	M10	18	10.8	17	SPP 6M8B 910
32	5781-10-13-0-00	32	7.1	7.1	8	M10	20	10.8	17	SPP 10M12B 910

NG	Bolt kit			Kit		Surface finish
				NBR	FPM	
10	BK505	4x M10x35 ISO 4762-12.9	63 Nm ±15 %	S26-58507-0	S26-58507-5	
25	BK485	4x M10x45 ISO 4762-12.9	63 Nm ±15 %	S26-58475-0	S26-58475-5	
32	BK506	6x M10x45 ISO 4762-12.9	63 Nm ±15 %	S26-58508-0	S26-58508-5	

<sup>1)</sup> Details see chapter 12, series SPP.

**Characteristics**

Direct operated pressure reducing valve with manual adjustment. Series VM is a direct operated, spring loaded 3-way pressure reducing valve, that is open in neutral position. The valve closes the connection when the pre-set pressure is exceeded.

Primary port: NG06 - P, NG10 - B

Secondary port: NG06 - A, NG10 - A

Tank port: NG06 - T, NG10 - Y

If the pressure increases due to an external influence the spool opens to port T until the pre-set pressure is reached.



NG06



NG10

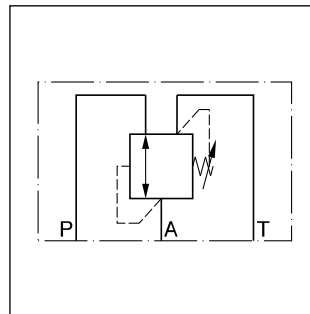

NG06

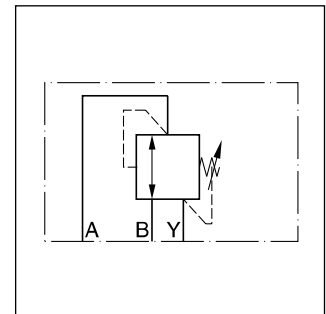

NG10

**4 Features**

- Spool type valve
- Subplate mounting acc. to ISO 5781
- 5 pressure stages at NG06
- 3 pressure stages at NG10
- 2 adjustment modes

**NG06**

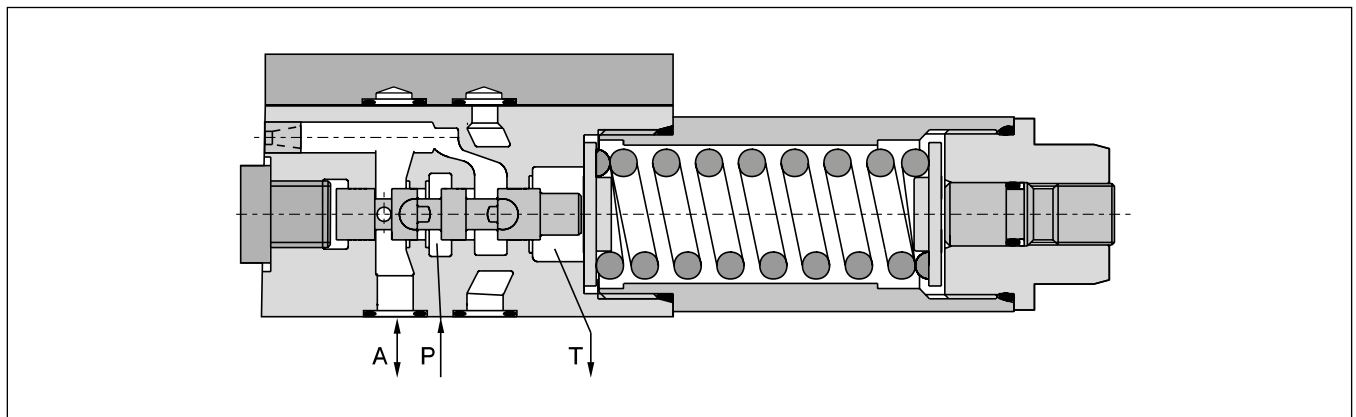

**NG10**

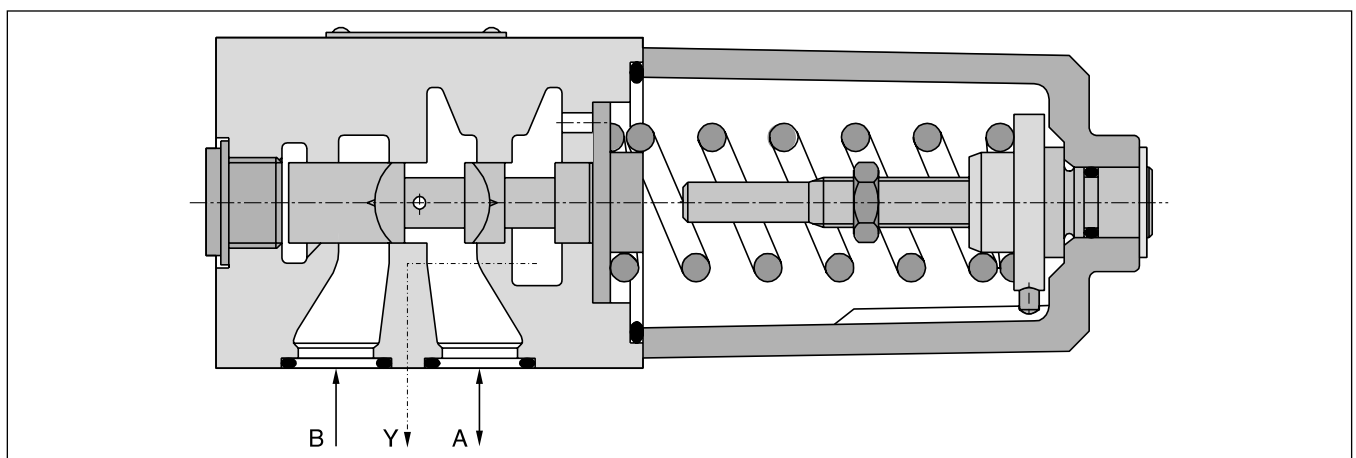

**Ordering code**

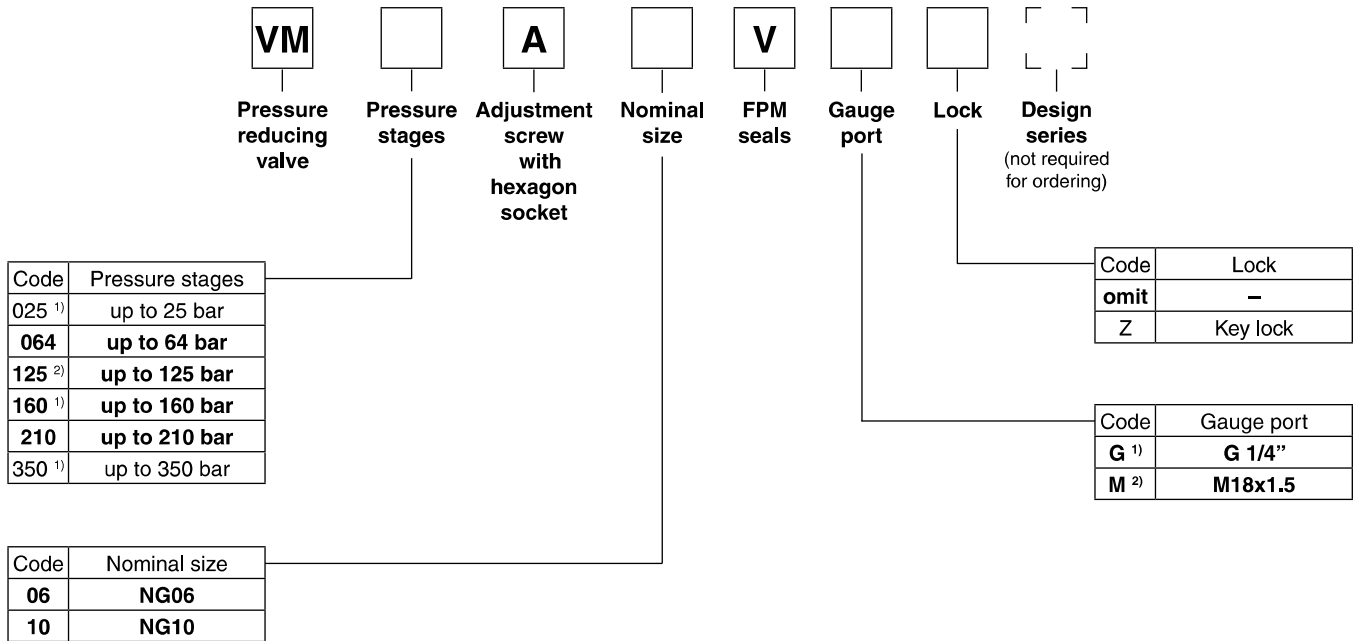

**Bold letters =  
 Short-term availability**

<sup>1)</sup> Only NG06.  
<sup>2)</sup> Only NG10.

**Technical data**

General		Pressure reducing valve, direct operated, spool type	
Design		Pressure reducing valve, direct operated, spool type	
Nominal size		<b>NG06 (CETOP 03 / NFPA D03)</b>	<b>NG10 (CETOP 05 / NFPA D05)</b>
Interface		Subplate mounting according to ISO 5781	
Mounting position		unrestricted	
Ambient temperature	[°C]	-20...+60	
MTTF <sub>D</sub> value	[years]	150	
Weight	[kg]	1.3	3.7
Hydraulics			
Max. operating pressure	[bar]	Port P and A 350 Port T depressurized	Port A and B 350 Port Y depressurized
Pressure stages	[bar]	25; 64; 160; 210; 350	64; 125; 210
Nominal flow	[l/min]	25	60
Fluid		Hydraulic oil according to DIN 51524	
Fluid temperature	[°C]	-20...+70	
Viscosity permitted	[cSt]/ [mm <sup>2</sup> /s]	20...400	
Viscosity recommended	[cSt]/ [mm <sup>2</sup> /s]	30...80	
Filtration		ISO 4406 (1999); 18/16/13	

**NG06 setting pressure max. 25 bar**

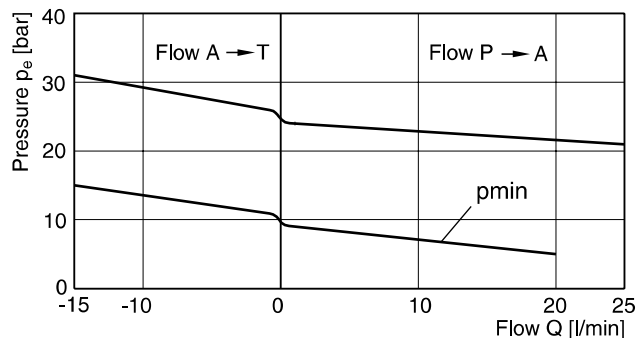

**NG06 setting pressure max. 160 or 210 bar**

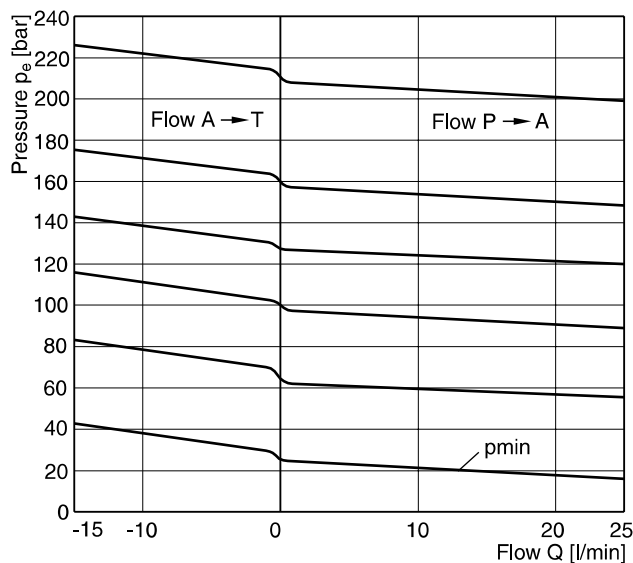

**4**

**NG06 setting pressure max. 64 bar**

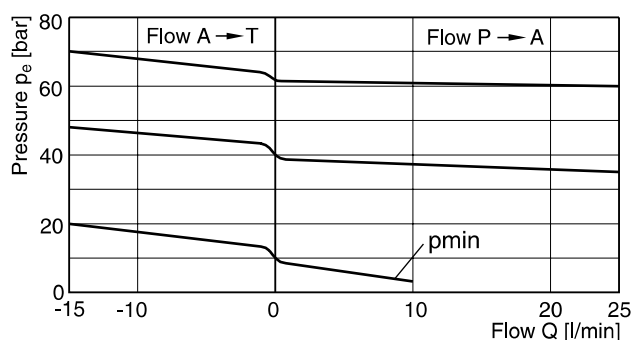

**NG10 setting pressure max. 64 bar**

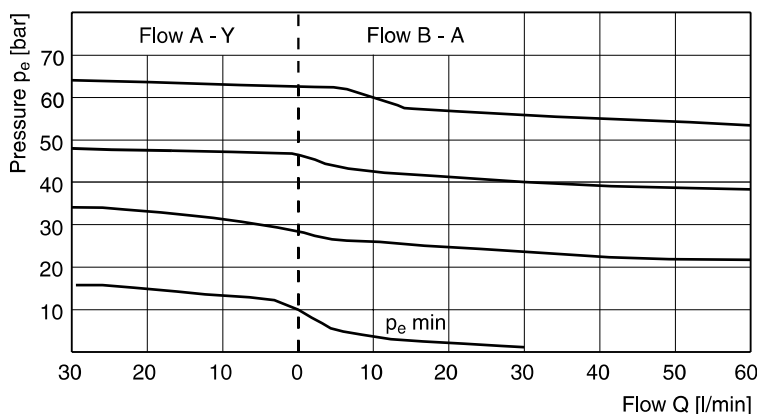

**NG10 setting pressure max. 210 bar**

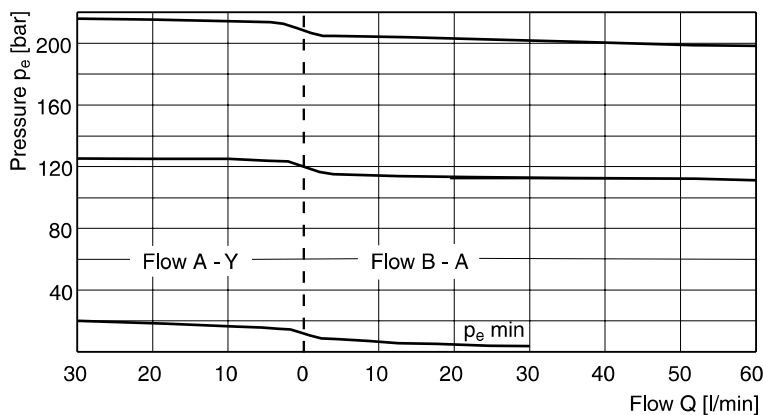



All characteristic curves measured with HLP46 at 50 °C.

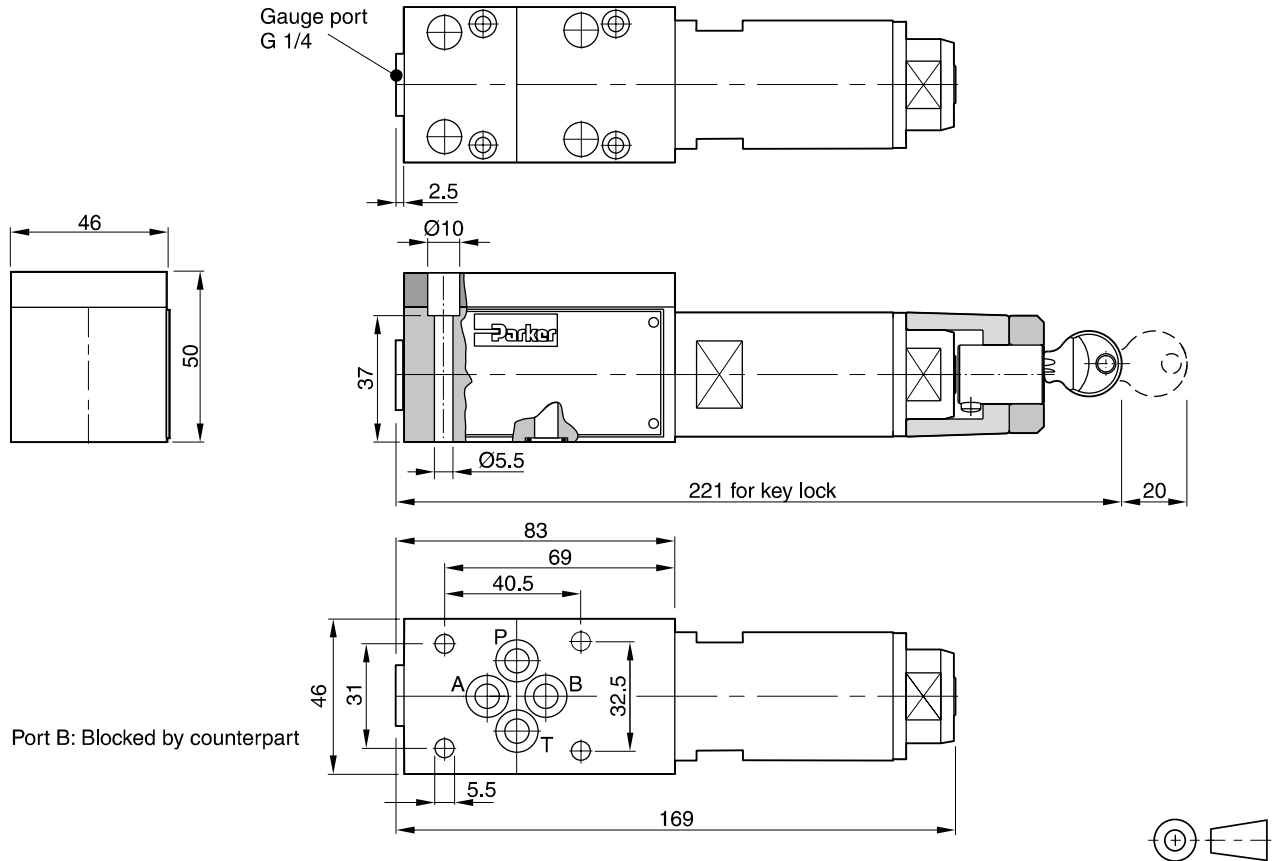

**NG06**



**4**

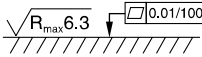

Surface finish	Bolt kit			 Kit FPM
	BK443	4x M5x45 ISO 4762-12.9	7.6 Nm ±15 %	SK-VB/VM/VS-A06V

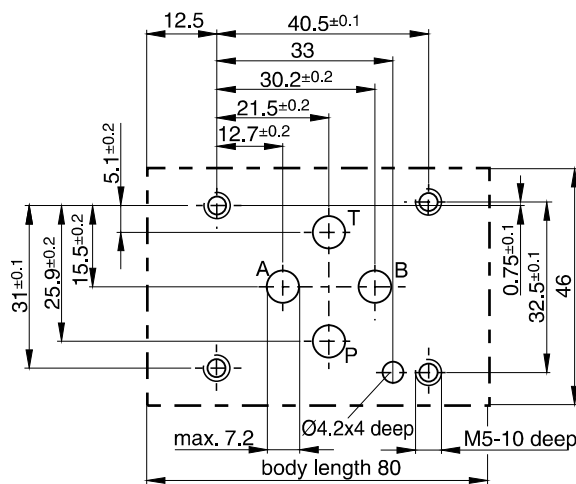
**Mounting pattern ISO 5781-03-04-0-00**

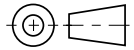
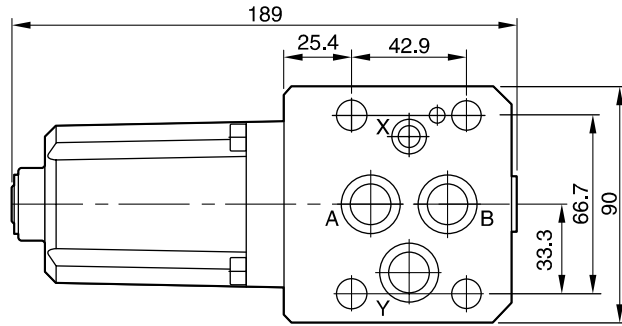
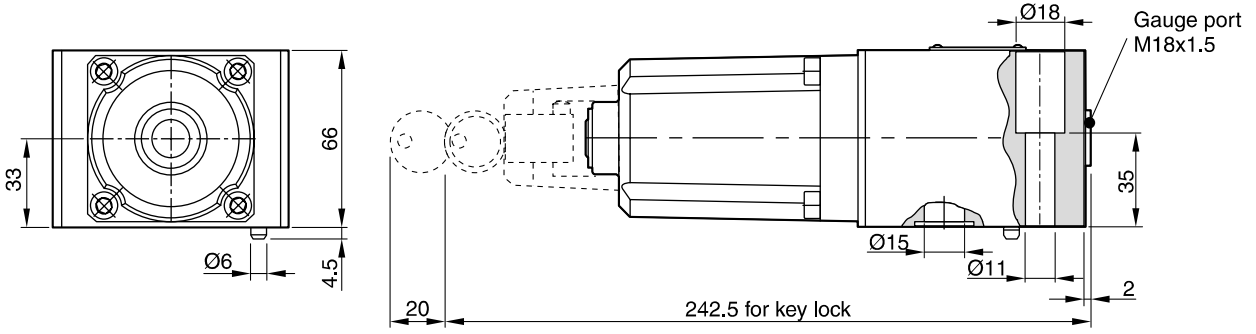

**NG10**

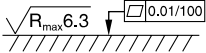

Surface finish	Bolt kit			 Kit FPM
	BK389	4x M10x50 ISO 4762-12.9	63 Nm ±15 %	SK-VB/VM-A10V

**Mounting pattern ISO 5781-06-07-0-00 <sup>1)</sup>**

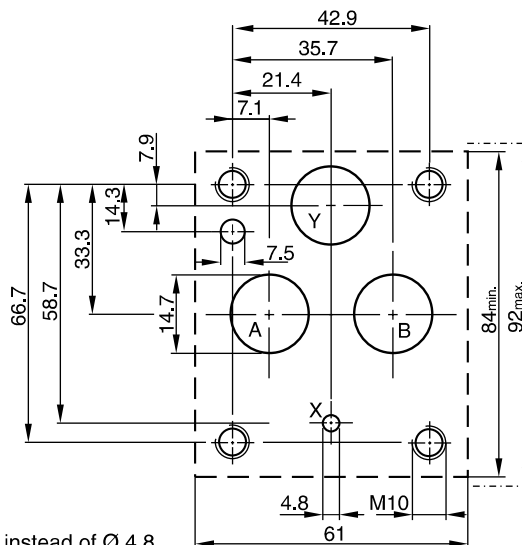

<sup>1)</sup> Deviating from ISO the Y port has Ø 14.7 instead of Ø 4.8.

Subplate mounted pressure reducing valves series R4R are used to control the pressure in the secondary part of the hydraulic system. Independent of the primary pressure the secondary pressure is reduced to the pressure setting. In order to avoid undesired motion the valves are normally closed.

**Features**

- Pilot operated with manual adjustment
- Subplate mounting acc. to ISO 5781
- Normally closed to avoid unintended motion
- 3 pressure stages
- 3 adjustment modes:
  - hand knob
  - acorn nut with lead seal
  - cylinder lock

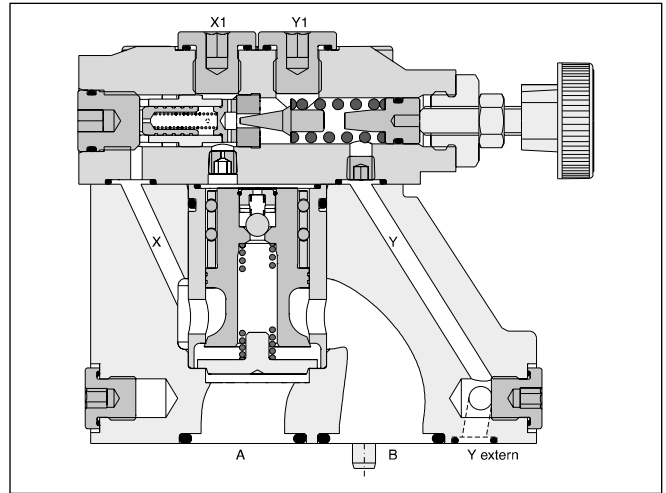
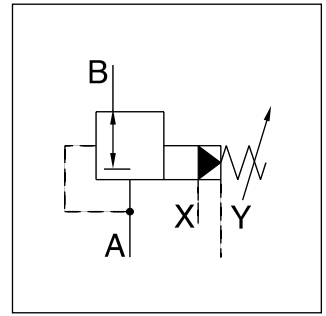

**4**

**Ordering code**

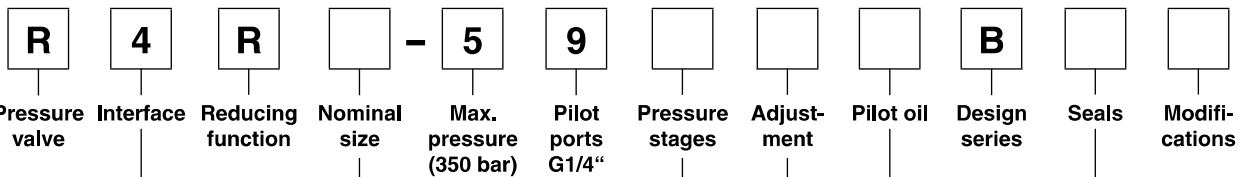

Code	Interface	
4	Subplate mounting ISO 5781	

Code	Seals
1	NBR
5	FPM

Code	Nominal size
03	NG10
06	NG25
10	NG32

Pilot oil		
Code	Pilot	Drain
1	Internal	External from Y
2	Internal	External from Y1

Code	Pressure stages <sup>1)</sup>
1	up to 105 bar
3	up to 210 bar
5	up to 350 bar

Code	Adjustment
1	Hand knob 32 mm diameter (standard)
3	Acorn nut with lead seal
4	Cylinder lock

<sup>1)</sup> Further pressure stages on request.

**Technical Data**

General				
Nominal size		NG10	NG25	NG32
Interface		Subplate mounting acc. ISO 5781		
Mounting position		Unrestricted, horizontal mounting preferred		
Ambient temperature	[°C]	-20...+60		
MTTF <sub>D</sub> value	[years]	75		
Weight	[kg]	2.7	4.5	6.0
Hydraulic				
Max. operating pressure	[bar]	Ports A, B and X 350, port Y depressurized		
Pressure stages	[bar]	105, 210, 350		
Nominal flow	[l/min]	150	350	500
Fluid		Hydraulic oil according to DIN 51524		
Viscosity, permitted recommended	[cSt] / [mm <sup>2</sup> /s]	20 ... 400		
	[cSt] / [mm <sup>2</sup> /s]	30 ... 80		
Fluid temperature	[°C]	-20...+70 (NBR: -25...+70)		
Filtration		ISO 4406 (1999); 18/16/13		

4

**Reduced pressure pA versus flow Q**

**R4R03** <sup>1)</sup>

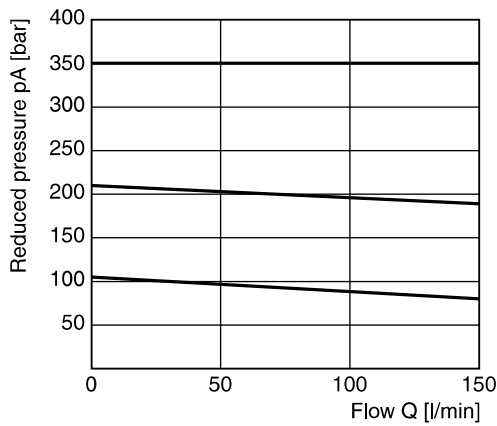

**Minimum pressure curve**

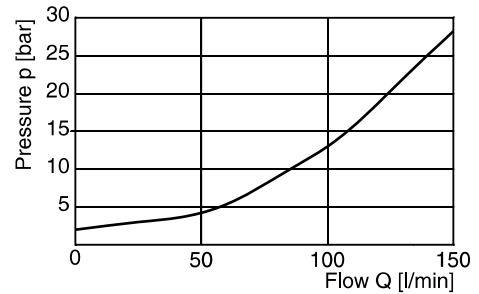

**Reduced pressure pA versus flow Q**

**R4R06** <sup>1)</sup>

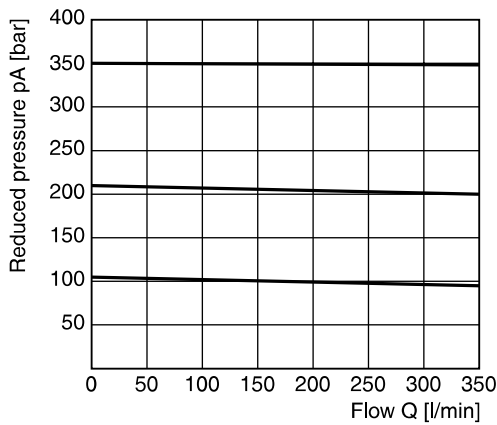

**Minimum pressure curve**

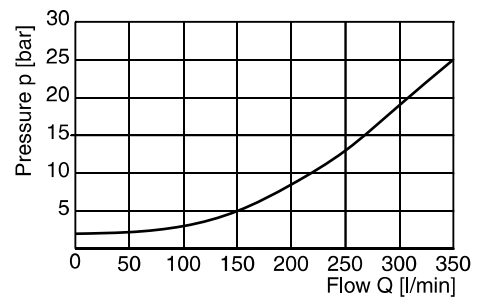

**Reduced pressure pA versus flow Q**

**R4R10** <sup>1)</sup>

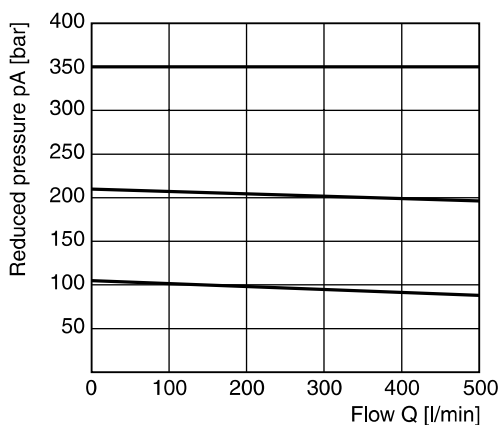

**Minimum pressure curve**

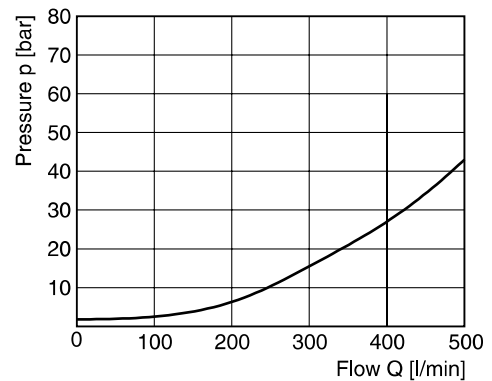

All characteristic curves measured with HLP46 at 50 °C.

<sup>1)</sup> Measured at 350 bar primary pressure pB.

R4R UK.indd 25.04.2019

Dimensions

4

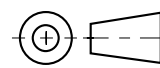
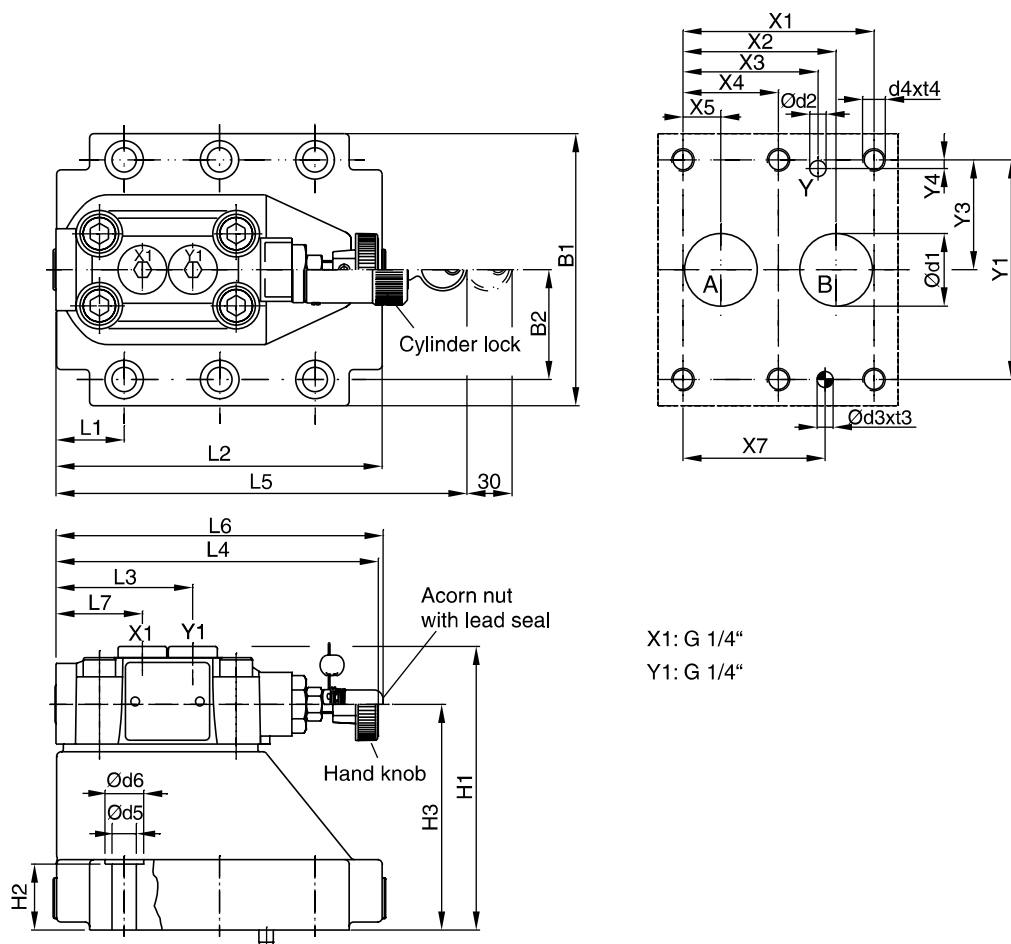

NG	ISO-code	x1	x2	x3	x4	x5	x6	x7	y1	y2	y3	y4	y5	y6
10	5781-06-07-0-00	42.9	35.8	21.5	-	7.2	-	31.8	66.7	-	33.4	7.9	-	-
25	5781-08-10-0-00	60.3	49.2	39.7	-	11.1	-	44.5	79.4	-	39.7	6.4	-	-
32	5781-10-13-0-00	84.2	67.5	59.5	42.1	16.7	-	62.7	96.8	-	48.4	3.8	-	-

Tolerance for all dimensions ±0.2

NG	ISO-code	B1	B2	H1	H2	H3	H4	H5	H6	L1	L2	L3	L4	L5	L6	L7
10	5781-06-07-0-00	87.3	33.35	87	21	62.5	-	-	-	25	90.8	60.8	143	181	144.8	38.6
25	5781-08-10-0-00	105	39.7	111.5	29	87	-	-	-	30.9	123	60.8	143	181	144.8	38.6
32	5781-10-13-0-00	120	48.4	124	30	99.5	-	-	-	29.8	143.5	60.8	143	181	144.8	38.6

NG	ISO-code	d1max	d2max	d3	t3	d4	t4	d5	d6	Subplate <sup>1)</sup>
10	5781-06-07-0-00	15	7	7.1	8	M10	16	10.8	17	SPP 3M6B 910
25	5781-08-10-0-00	23.4	7.1	7.1	8	M10	18	10.8	17	SPP 6M8B 910
32	5781-10-13-0-00	32	7.1	7.1	8	M10	20	10.8	17	SPP 10M12B 910

NG	Bolt kit			Kit		Surface finish
				NBR	FPM	
10	BK505	4x M10x35 ISO 4762-12.9	63 Nm ±15 %	S26-58507-0	S26-58507-5	
25	BK485	4x M10x45 ISO 4762-12.9	63 Nm ±15 %	S26-58475-0	S26-58475-5	
32	BK506	6x M10x45 ISO 4762-12.9	63 Nm ±15 %	S26-58508-0	S26-58508-5	

<sup>1)</sup> Details see chapter 12, series SPP.

**Characteristics**

**Pilot Operated Proportional Reducing Valve Series VMY**

Proportional pressure reducing valves of the series VMY allow the variable adjustment of the reduced pressure from 0 bar up to the nominal pressure.

The valve consists of a spool type main stage and a proportionally operated pilot stage. The desired pressure can be variably set corresponding to the command signal specified on the amplifier. The proportional solenoid converts the current of the amplifier into force on the valve poppet of the pilot stage.

Typical applications are pressure systems, test equipment, or counterweight systems. The optimum performance can be achieved in combination with the digital amplifier module PCD00A-400 for open loop systems or with PWDXXA-40\* for closed loop systems.

**Function VMY\*K06**

With the proportional solenoids de-energized the main spring forces the main spool into the neutral position. Port A is connected to port T. Thus the reduced pressure only depends on the back pressure in the external drain pipe and/or the tank pressure and can accordingly be reduced down to 0 bar. The pressure present in the P line delivers the pilot oil to the pilot stage via a flow control valve.

When the proportional solenoid is energized, the pilot pressure is increased in the pilot pressure area, and the main spool moves against the spring until the connection P - A opens. The regulation of the reduced pressure on connection A takes place by the constant comparison of the actual pressure and the reference pressure of the pilot stage.



VMY\*K06

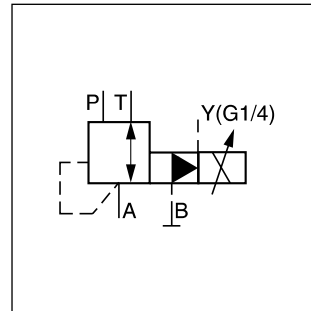

VMY\*K06

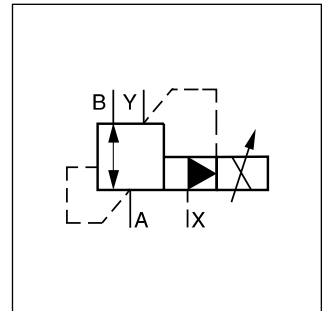

VMY\*K10

**4**

**VMY\*K10**

The valve spool is designed so that the connection B-A is open in the neutral position and is closed in the working position.

**VMY\*K06N**

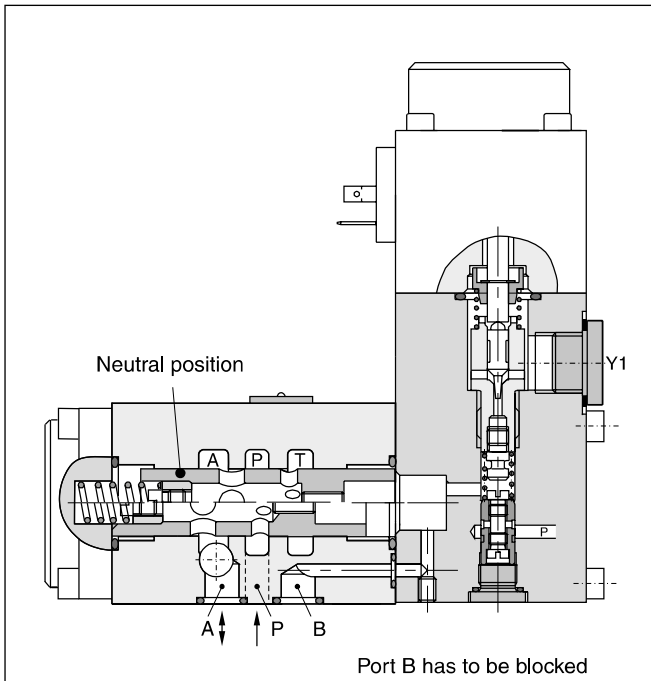

**VMY\*K10**

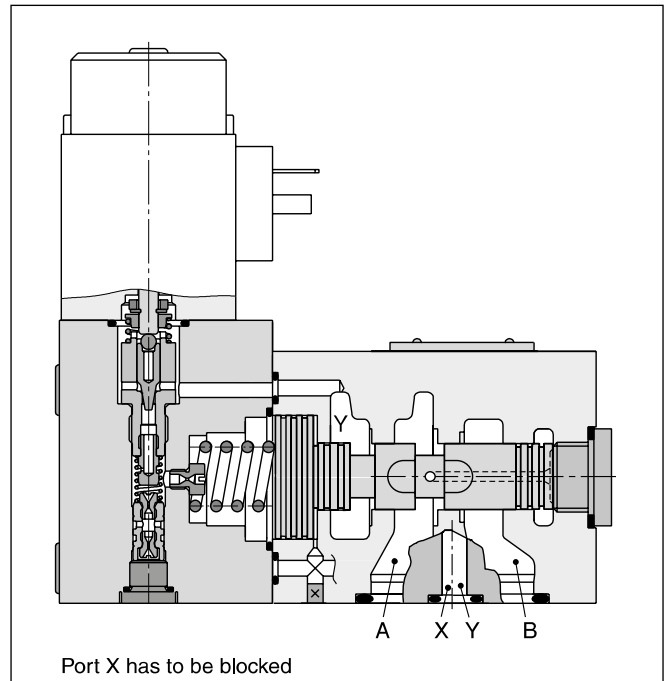

**Ordering code**

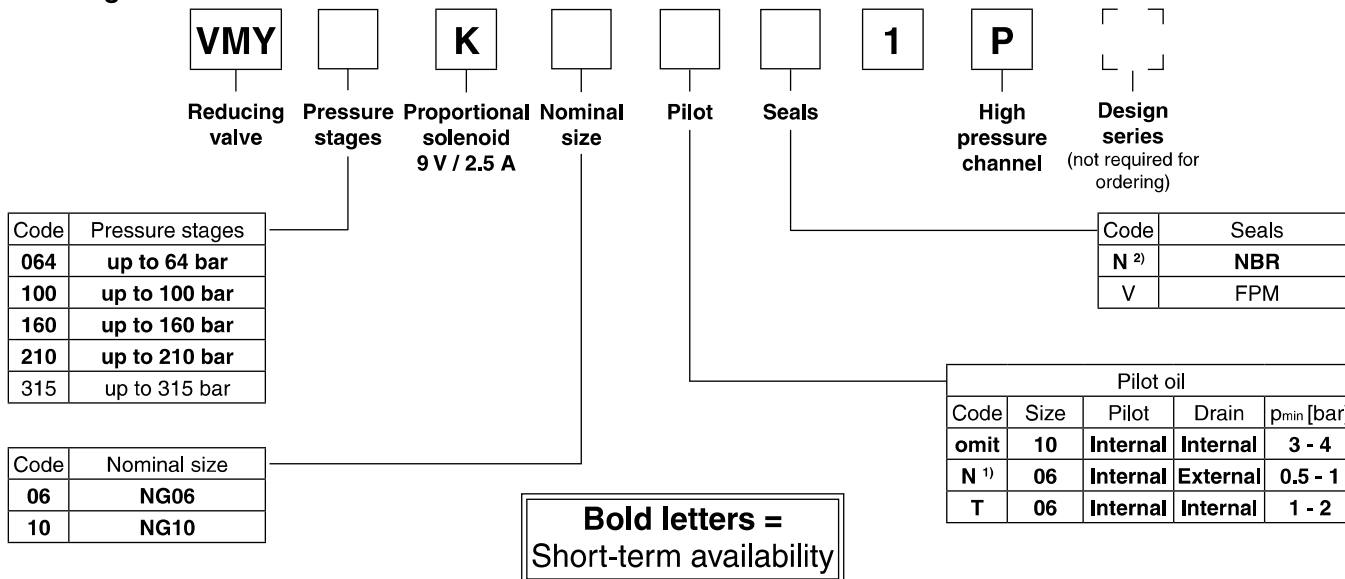

**Technical data**

General				
Design	3 way proportional reducing valve, pilot operated, spool design			
Nominal size	<b>06 (DIN NG06/CETOP 03/NFPA D03)</b>		<b>10 (DIN NG10/CETOP 05/NFPA D05)</b>	
Interface	Subplate mounting according to ISO 5781			
Actuation	Proportional solenoid			
Mounting position	unrestricted			
Ambient temperature	[°C]	-20 ... +60		
MTTF <sub>D</sub> value	[years]	75		
Weight	[kg]	2.8	5	
Hydraulics				
Max. operating pressure	[bar]	Size 06: Ports P, A 315; Port T, Y depressurized; port B has to be blocked Size 10: Ports A, B 350; Port Y depressurized; port X has to be blocked		
Pressure stages	[bar]	64, 100, 160, 210, 315		
Nominal flow	[l/min]	40	160	
Fluid	Hydraulic oil according to DIN 51524			
Viscosity	permitted [cSt] / recommended [cSt]	20 ... 400	30 ... 80	
Fluid temperature	[°C]	-20...+70 (NBR: -25...+70)		
Filtration	ISO 4406 (1999); 18/16/13			
Linearity	[%]	See characteristic pressure curves	±3.5 at > 15 % p <sub>nom</sub>	
Repeatability	[%]	<±2		
Hysteresis	[%]	<3		
Response time	[ms]	<150	<200	
Electrical				
Duty ratio	[%]	100 ED		
Protection class	IP65 in accordance with EN 60529 (with correctly mounted plug-in connector)			
Nominal voltage	[VDC]	9		
Max. current	[A]	2.7		
Nom. current	[A]	2.5		
Ambient temperature	[°C]	-20...+70		
Coil resistance	[Ohm]	-2.1 (at 20 °C)		
Solenoid connection	Connector as per EN 175301-803			
Power amplifier, recommended	PCD00A-400			

<sup>1)</sup> Connection on port Y1 or Y2.

<sup>2)</sup> Not for NG06.



**NG06 Characteristic pressure lines  $p = f(U_{set})$**

Setting range max. 64 bar

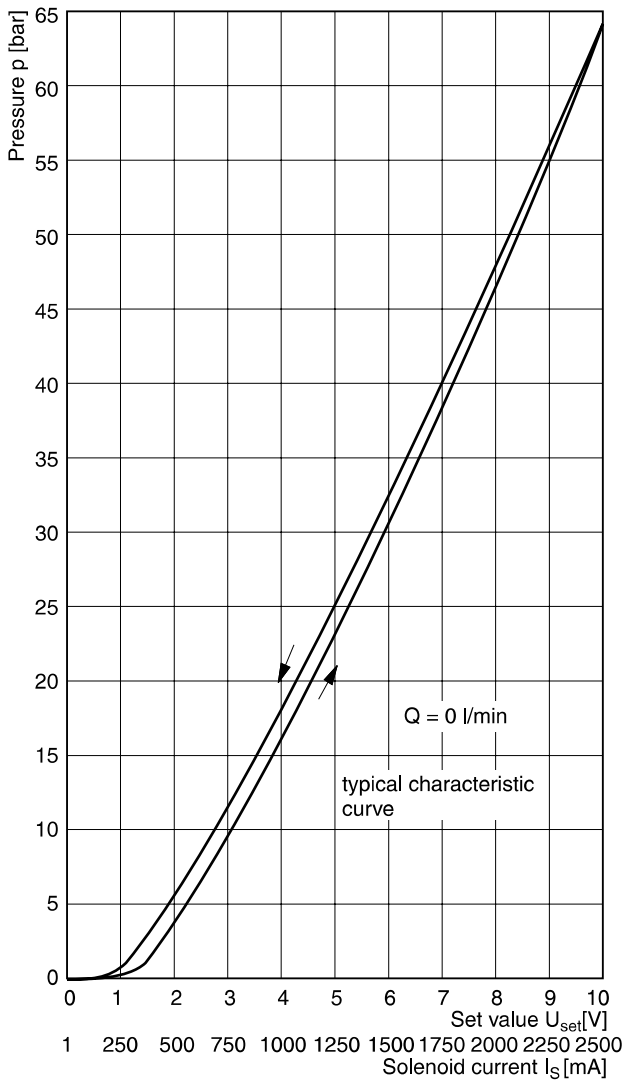

Setting range max. 210 bar

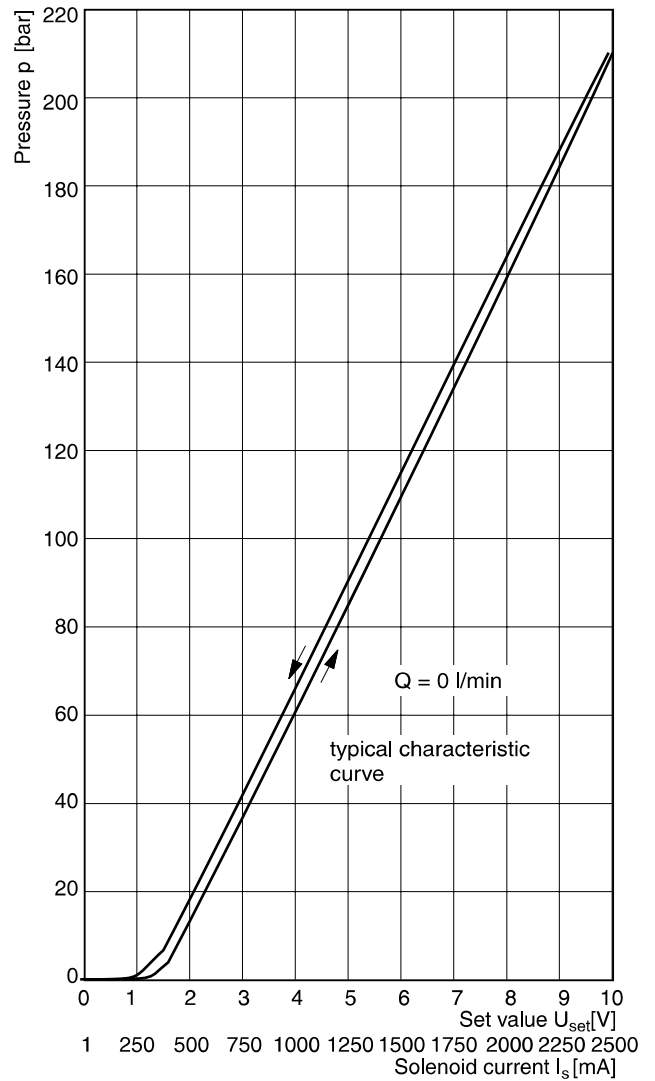

**NG06 p/Q characteristics**

Setting range max. 64 bar

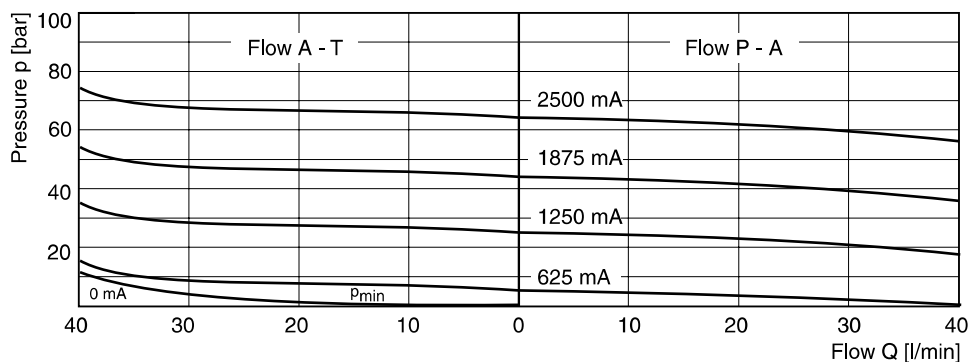

All characteristic curves measured with HLP46 at 50 °C.

VMY UK.INDD 25.04.2019

**NG06 p/Q characteristics**

**Setting range max. 100 bar**

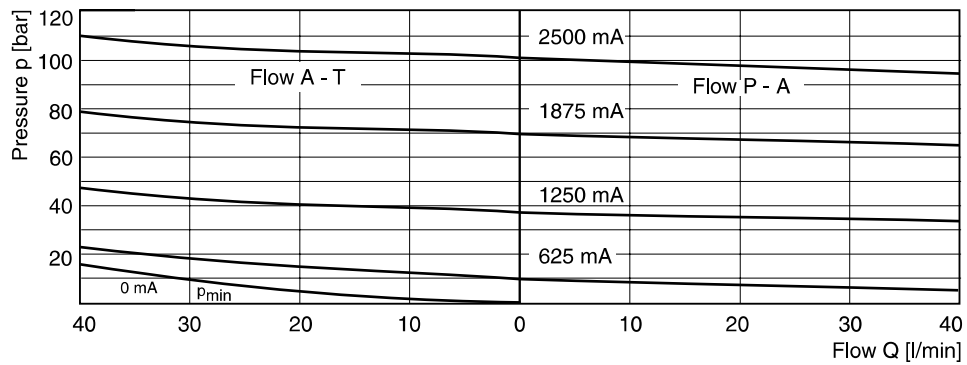

**4**

**Setting range max. 160 bar**

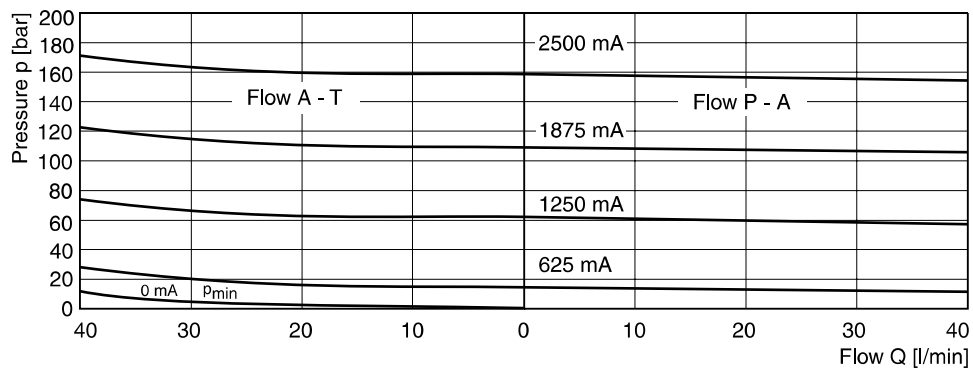

**Setting range max. 210 bar**

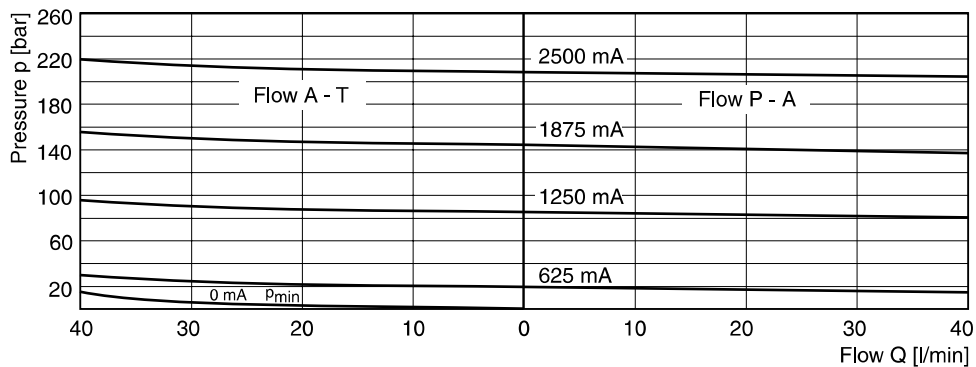

**Setting range max. 315 bar**

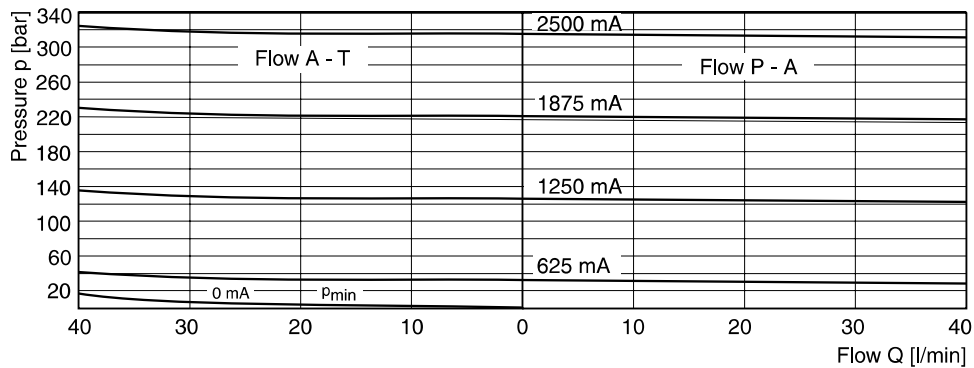

All characteristic curves measured with HLP46 at 50 °C.

**Step response**

Typical curve

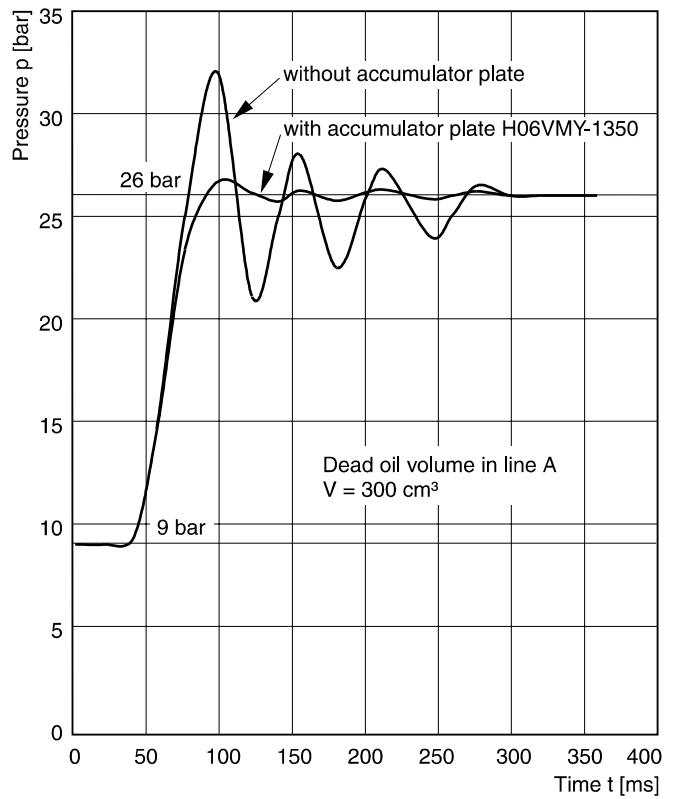
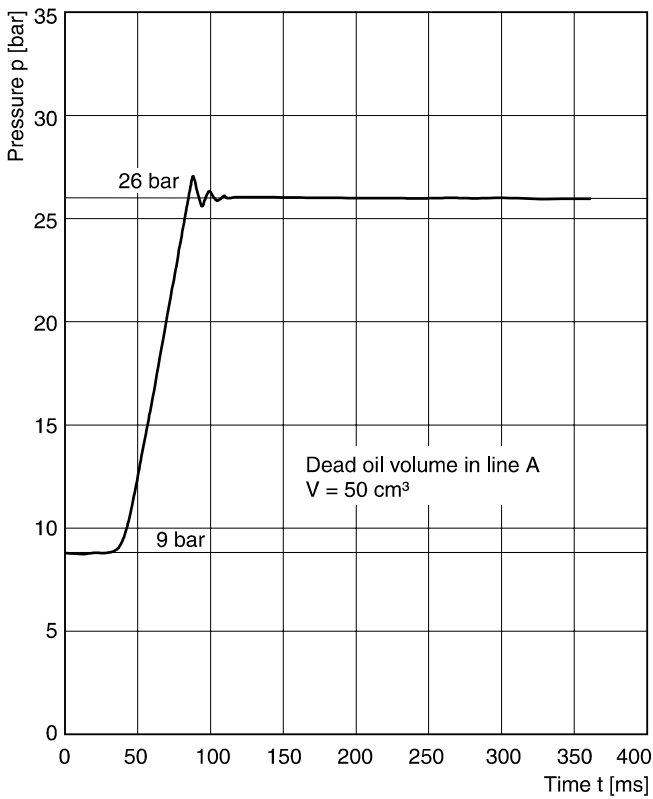

All characteristic curves measured with HLP46 at 50 °C.

**4**

**Accumulator plate H06VMY-1350**

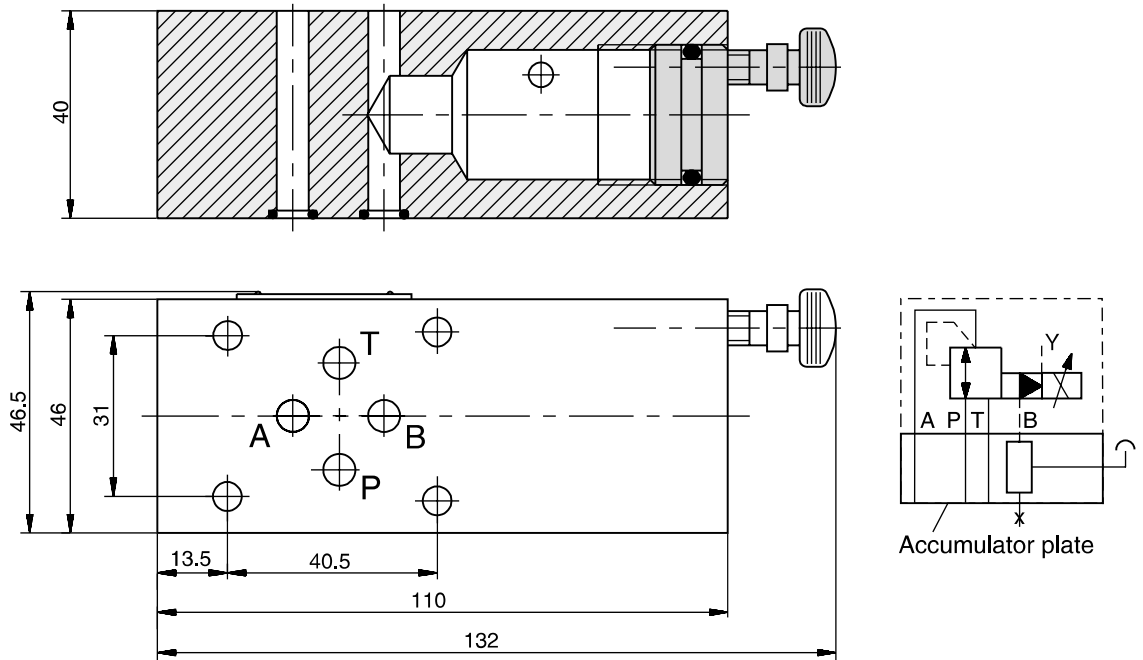

**NG10 p/Q characteristics**  
 for pilot oil supply from high pressure channel P

**Setting range max. 64 bar**

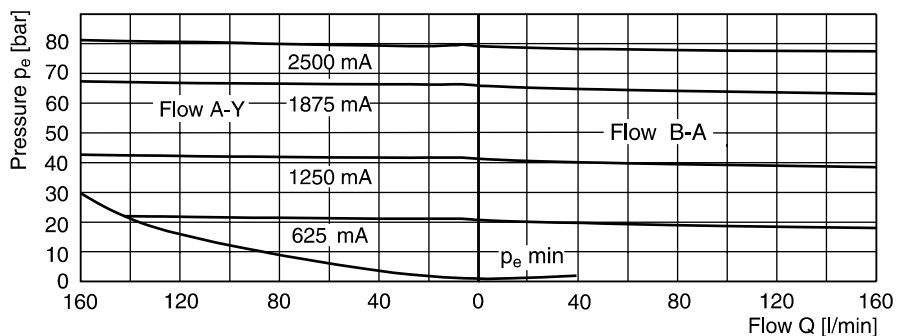

**Setting range max. 100 bar**

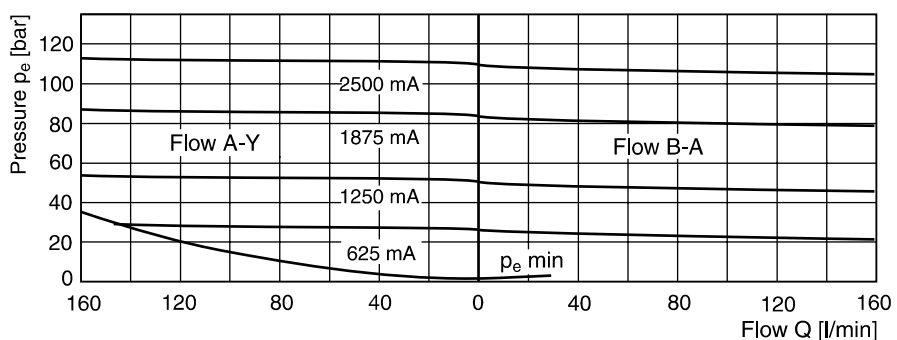

**Setting range max. 160 bar**

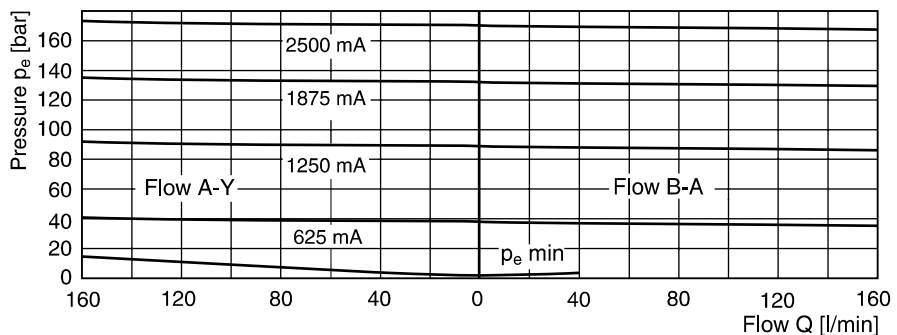

**Setting range max. 210 bar**

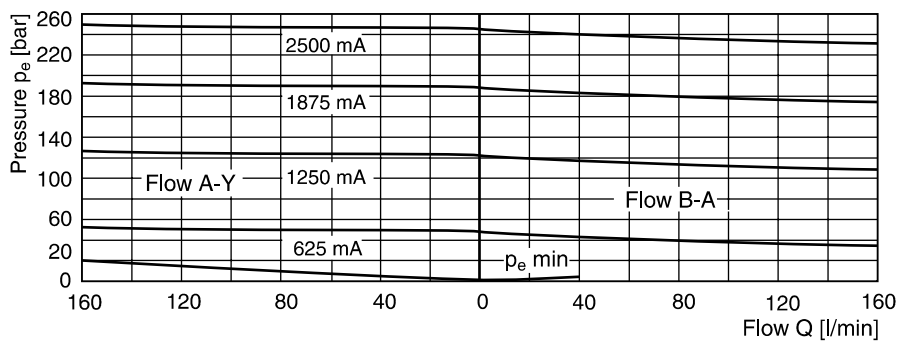

All characteristic curves measured with HLP46 at 50 °C.

VMY UK.INDD 25.04.2019

4

**NG06**

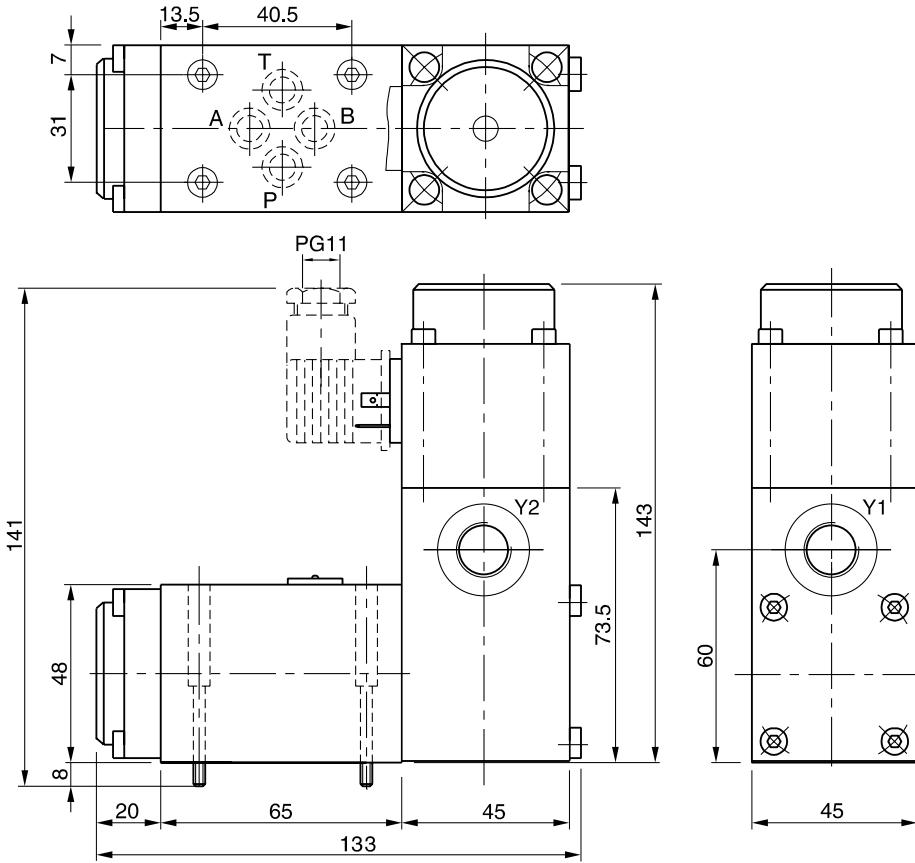



Port Y: G1/4

VMY\*K06T:  
Ports Y1 and Y2: closed

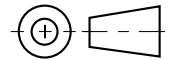
VMY\*K06N:  
Drain port Y1 or Y2  
Port Y1 closed,  
Port Y2 opened

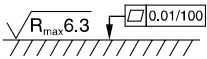

**4**

Surface finish	Bolt kit			 Kit FPM
	BK375	4x M5x30 ISO 4762-12.9	7.6 Nm ±15 %	SK-VMY-L06-V

**Mounting pattern ISO 5781-03-04-0-00**

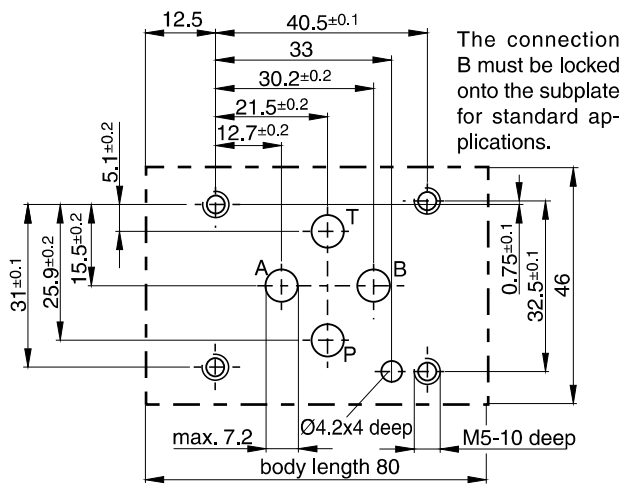



Dimensions

NG10

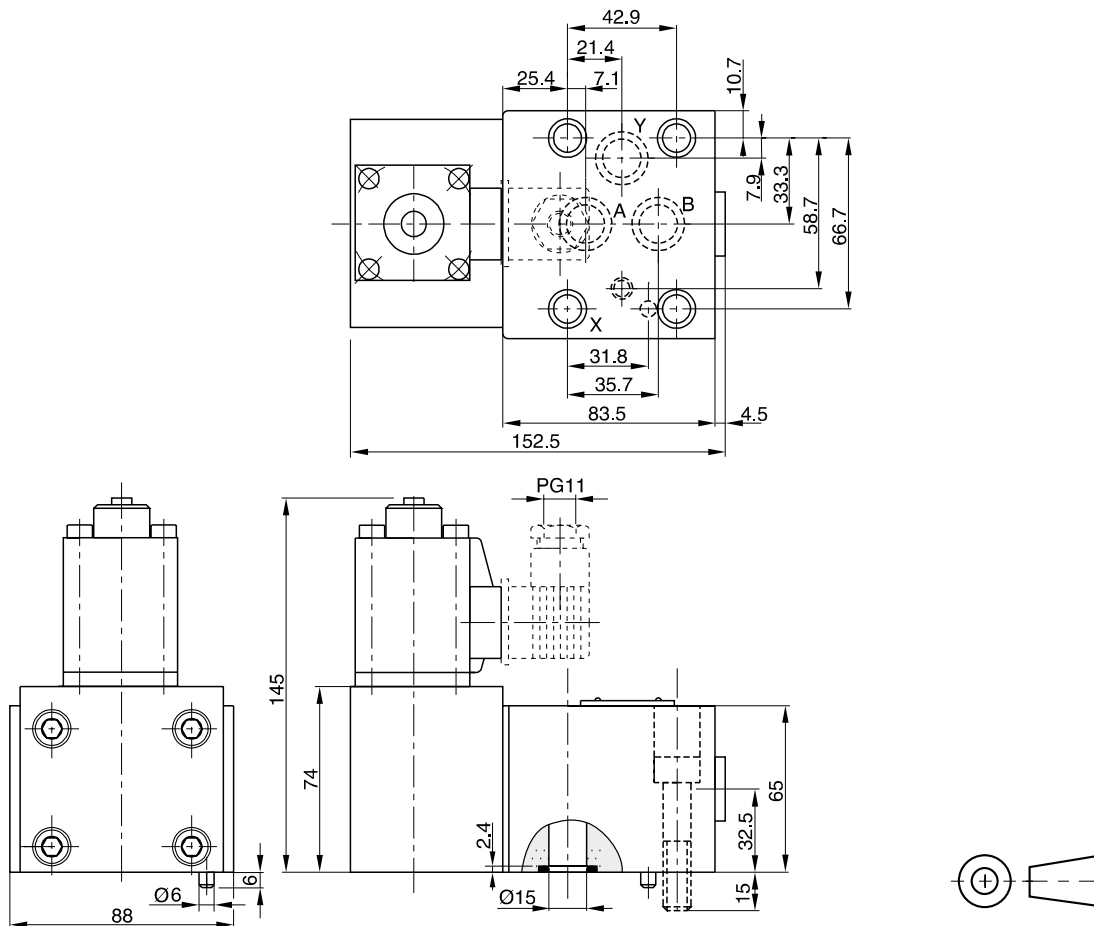
4

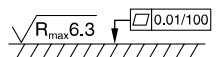

Surface finish	Bolt kit			 Kit FPM
	BK389	4x M10x50 ISO 4762-12.9	63 Nm ±15 %	SK-VB/VM-A10V

Mounting pattern ISO 5781-06-07-0-00 <sup>1)</sup>

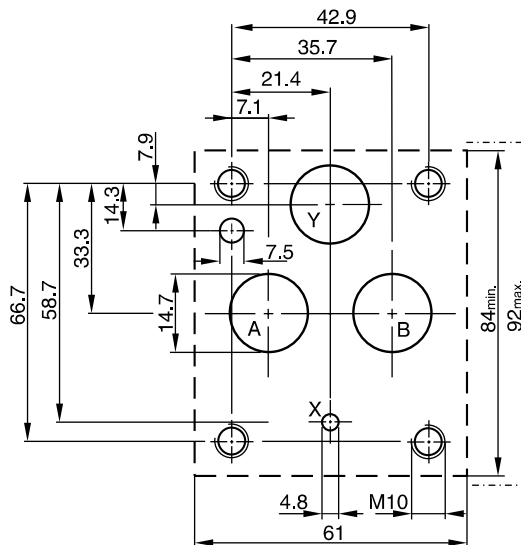

<sup>1)</sup> Deviating from ISO the Y port has Ø 14.7 instead of Ø 4.8.

Subplate mounted proportional pressure reducing valves series R4R have a proportional solenoid operated pilot stage and a cartridge main stage.

The optimum performance can be achieved in combination with the digital amplifier module PCD00A-400.

**Features**

- Pilot operated with proportional solenoid
- Continuous adjustment by proportional solenoid
- Subplate mounting according to ISO 5781
- 3 pressure stages
- With mechanical maximum pressure adjustment

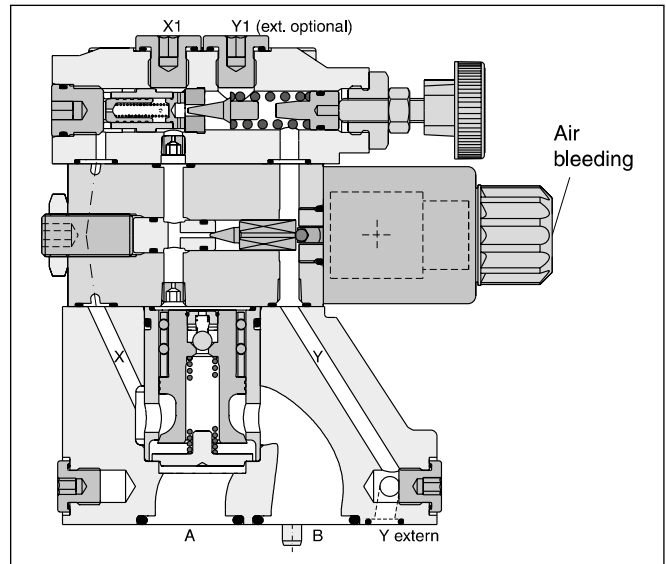
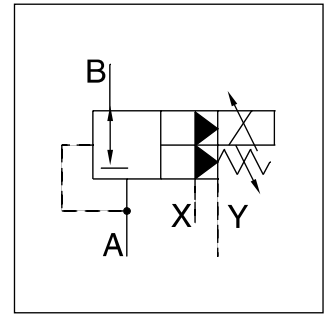

**4**

**Ordering code**

<b>R</b>	<b>4</b>	<b>R</b>		<b>- 5</b>	<b>9</b>				<b>P2</b>	<b>G0R</b>	<b>B</b>		
Pressure valve	Interface	Reducing function	Nominal size	Max. pressure 350 bar	Pilot ports G1/4"	Pressure stages	Adjustment	Pilot oil	Prop. operation	Solenoid voltage 12 V, 2.3 A	Design series	Seal	Modifications

Interface	
Code	Interface
4	Subplate mounting ISO 5781

Code	Nominal size
03	NG10
06	NG25
10	NG32

Code	Pressure stages
1	up to 105 bar
3	up to 210 bar
5	up to 350 bar

Pilot oil		
Code	Pilot	Drain
1	Internal	External from Y
2	Internal	External from Y1

Seals	
Code	Seals
1	NBR
5	FPM

Adjustment	
Code	Adjustment
1	Hand knob 32 mm diameter (standard)
3	Acorn nut with lead seal

**Technical Data / Characteristics Curves**

**Technical data**

General		
Nominal size		<b>NG10</b> <b>NG25</b> <b>NG32</b>
Interface	Subplate mounting acc. ISO 5781	
Mounting position	Unrestricted, horizontal mounting preferred	
Ambient temperature	[°C]	-20...+60
MTTF <sub>D</sub> value	[years]	75
Weight	[kg]	4.8      7.2      13.5
Hydraulic		
Max. operating pressure	[bar]	Ports A, B and X 350, port Y depressurized
Pressure stages	[bar]	105, 250, 350
Nominal flow	[l/min]	150      350      500
Fluid	Hydraulic oil according to DIN 51524	
Viscosity, permitted	[cSt] / [mm²/s]	20 ... 400
	recommended	30 ... 80
Fluid temperature	[°C]	-20...+70 (NBR: -25...+70)
Filtration	ISO 4406 (1999); 18/16/13	
Electrical		
Duty ratio	[%]	100 ED
Protection class	IP65 in accordance with EN 60529 (with correctly mounted plug-in connector)	
Nominal voltage	[V]	12
Max. current	[A]	2.3
Coil resistance	[Ohm]	4 at 20 °C
Solenoid connection	Connector as per EN 175301-803	
Power amplifier, recommended	PCD00A-400	

4

**Command/pressure curves**

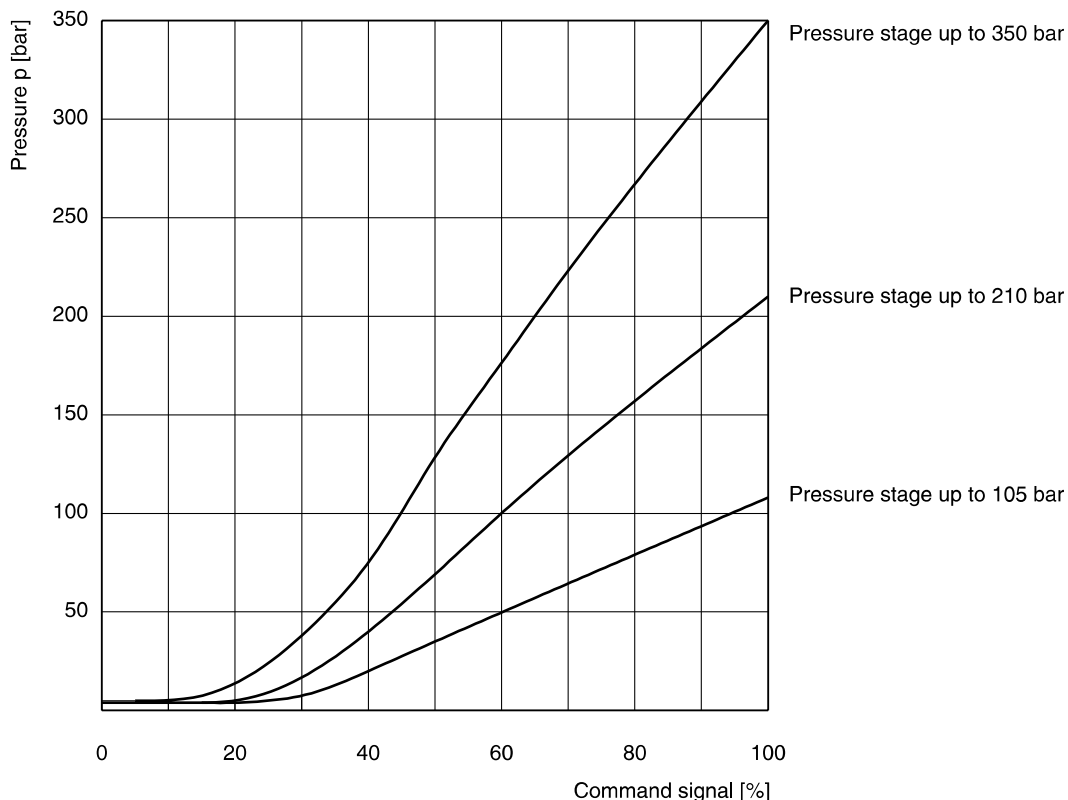

All characteristic curves measured with HLP46 at 50 °C.



**Reduced pressure pA versus flow Q**

**R4R03** <sup>1)</sup>

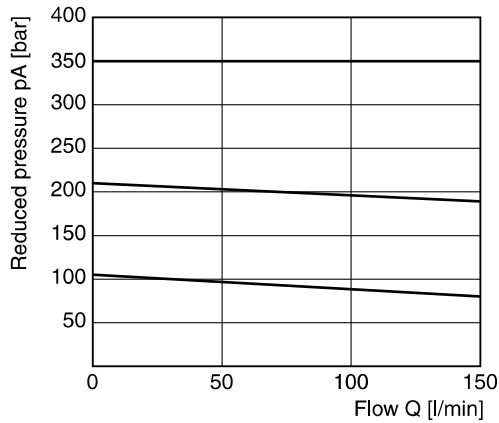

**Minimum pressure curve**

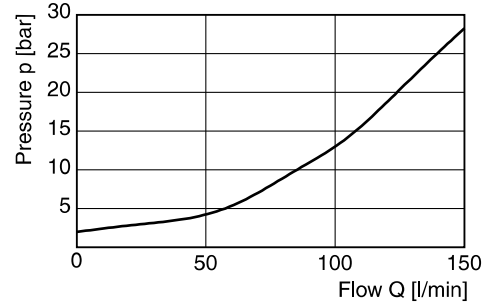

**Reduced pressure pA versus flow Q**

**R4R06** <sup>1)</sup>

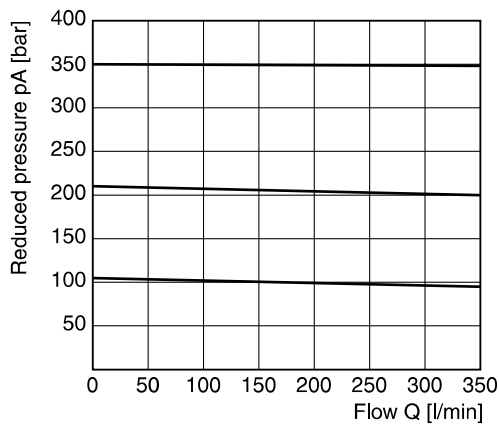

**Minimum pressure curve**

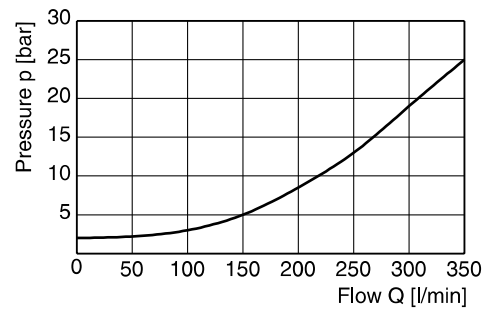

**Reduced pressure pA versus flow Q**

**R4R10** <sup>1)</sup>

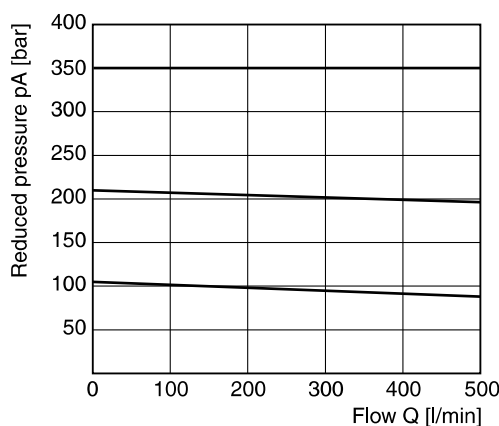

**Minimum pressure curve**

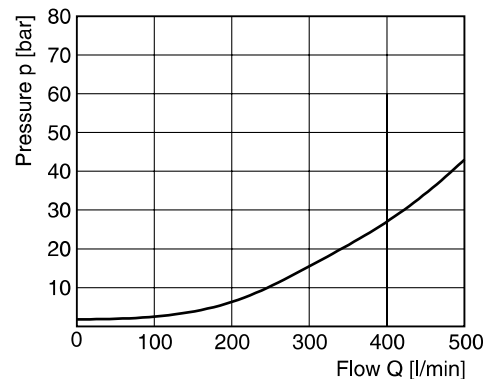

All characteristic curves measured with HLP46 at 50 °C.

<sup>1)</sup> Measured at 350 bar primary pressure pB.

Dimensions

4

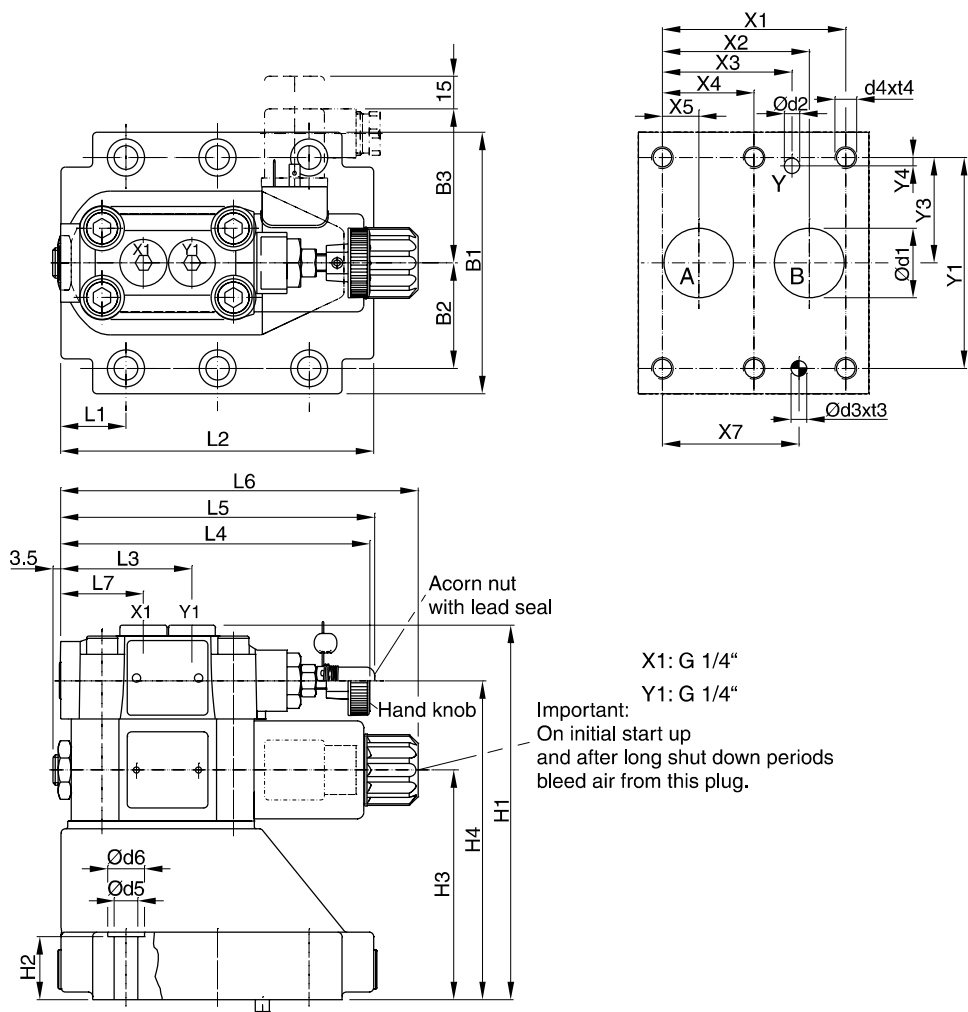

X1: G 1/4"  
Y1: G 1/4"  
Important:  
On initial start up  
and after long shut down periods  
bleed air from this plug.

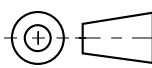

NG	ISO-code	x1	x2	x3	x4	x5	x6	x7	y1	y2	y3	y4	y5	y6
10	5781-06-07-0-00	42.9	35.8	21.5	-	7.2	-	31.8	66.7	-	33.4	7.9	-	-
25	5781-08-10-0-00	60.3	49.2	39.7	-	11.1	-	44.5	79.4	-	39.7	6.4	-	-
32	5781-10-13-0-00	84.2	67.5	59.5	42.1	16.7	-	62.7	96.8	-	48.4	3.8	-	-

Tolerance for all dimensions ±0.2

NG	ISO-code	B1	B2	B3	H1	H2	H3	H4	L1	L2	L3	L4	L5	L6	L7
10	5781-06-07-0-00	87.3	33.35	71	134	21	68.5	109.5	25	90.8	60.8	143	144.8	164.8	38.6
25	5781-08-10-0-00	105	39.7	71	158.5	29	93	134	30.9	123	60.8	143	144.8	164.8	38.6
32	5781-10-13-0-00	120	48.4	71	171	30	105.5	146.5	29.8	143.5	60.8	143	144.8	164.8	38.6

NG	ISO-code	d1max	d2max	d3	t3	d4	t4	d5	d6	Subplate <sup>1)</sup>
10	5781-06-07-0-00	15	7	7.1	8	M10	16	10.8	17	SPP 3M6B 910
25	5781-08-10-0-00	23.4	7.1	7.1	8	M10	18	10.8	17	SPP 6M8B 910
32	5781-10-13-0-00	32	7.1	7.1	8	M10	20	10.8	17	SPP 10M12B 910

NG	Bolt kit			Kit		Surface finish
				NBR	FPM	
10	BK505	4x M10x35 ISO 4762-12.9	63 Nm ±15 %	S26-58507-0 <sup>2)</sup>	S26-58507-5 <sup>2)</sup>	
25	BK485	4x M10x45 ISO 4762-12.9	63 Nm ±15 %	S26-58475-0 <sup>2)</sup>	S26-58475-5 <sup>2)</sup>	
32	BK506	6x M10x45 ISO 4762-12.9	63 Nm ±15 %	S26-58508-0 <sup>2)</sup>	S26-58508-5 <sup>2)</sup>	
Prop. section P2				S26-58473-0	S26-58473-5	

<sup>1)</sup> Details see chapter 12, series SPP.

<sup>2)</sup> Please combine seal kit of one size with seal kit of Prop. section P2 for complete seal kit.

Description	Threaded cable joint	Body colour coding	Figures switching	Order no.
Plug EN 175301-803 <sup>1)</sup> , design type AF, protection class IP65 voltages up to 250 V	PG 9	black, B grey, A	Fig. 1	<b>5001710</b> <b>5001711</b>
	PG11	black, B grey, A	Fig. 1	<b>5001716</b> <b>5001717</b>
Plug with LED insert 24 V	PG11	black, B grey, A	Fig.1 and Fig. 3	<b>5001571</b> <b>5001572</b>
Plug with lamp insert 110 V	PG11	black, B grey, A	Fig.1 and Fig. 4	<b>5001573</b> <b>5001574</b>
Plug with lamp insert 230 V	PG11	black, B grey, A	Fig.1 and Fig. 4	<b>5001575</b> <b>5001576</b>
Plug with LED insert 24 V and suppressing circuitry	PG11	black, B grey, A	Fig.1 and Fig. 5	<b>5001708</b> <b>5001709</b>
Plug with rectifier. Rectifier with 4 silicon diodes in bridge circuit. Varistor in alternating current side to protect the diodes against power peaks	PG11	black, B grey, A	Fig.1 and Fig. 6	<b>5001737</b> <b>5001738</b>
Plug with pull relief and translucent cover	PG11	black, B grey, A	Fig. 2	<b>5001723</b> <b>5001724</b>
Application with bridge rectifier suitable for 5001723 and 5001724	—	—	Fig. 2 and Fig. 7	<b>5001727</b>
Application with bridge rectifier and lamp suitable for 5001723 and 5001724	—	—	Fig. 2 and Fig. 8	<b>5001734</b>

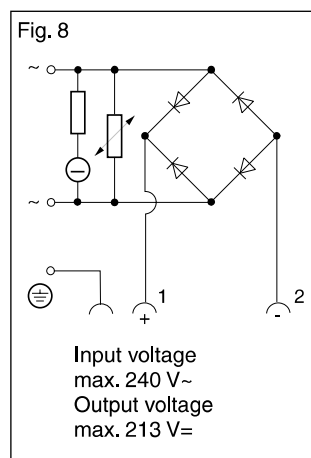
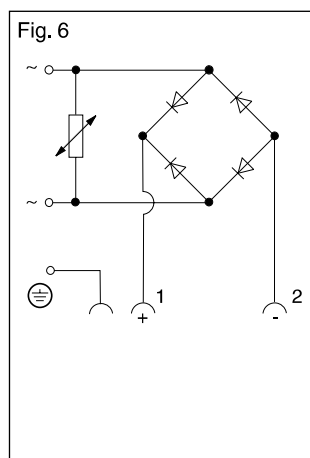
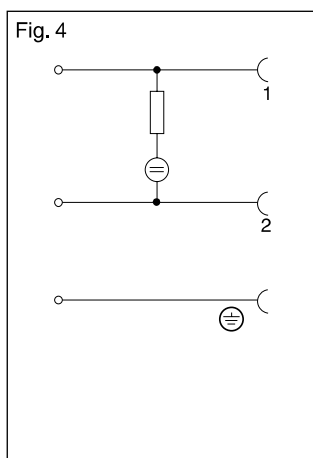
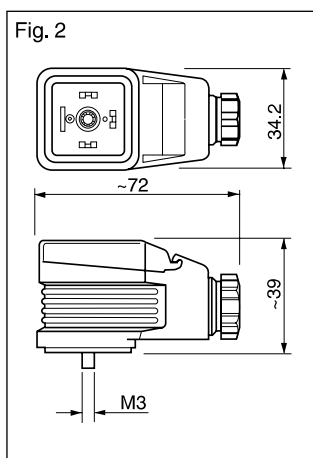
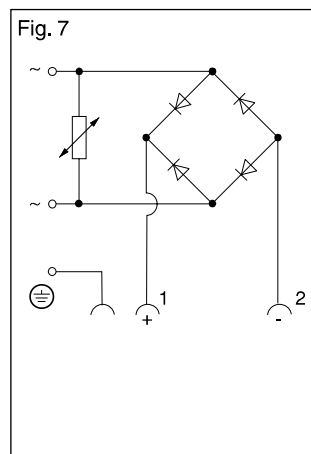
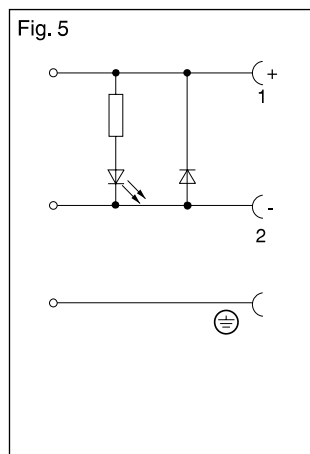
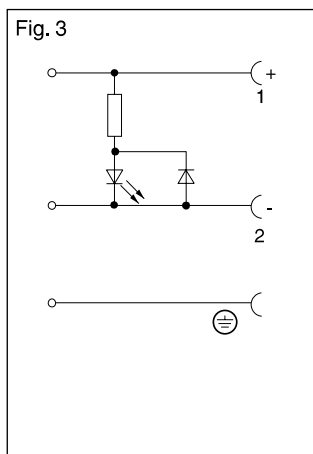
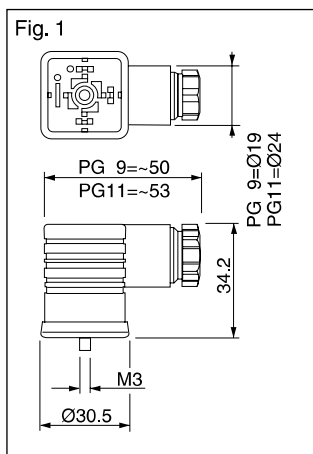

<sup>1)</sup> EN 175301-803 (new) corresponding with DIN 43650 (old).

**Central connector**

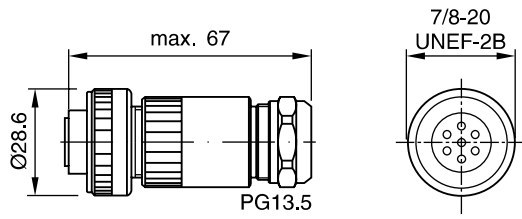

Description	Order No.
DIN 43563 6+PE	5004072