

Flowmeters & Monitors

A range of cost saving solutions



**Protect systems,
reduce fluid and air
loss and increase
efficiency**

**Effective and accurate flow
measurement**

An extensive range of flow metering products. LoFlow oil and water flowmeters. 10 bar max. working pressure. Easiflow meters and flowswitches with flows from 1 to 150 l/min. Dataflow 4-20mA and pulse output flow transmitters and the Dataflow Compact inline flow transmitter. Flowline oil, water and air calibrated flowmeters and flowswitches available in brass or Stainless Steel. Hydraulic Test Units for the speedy diagnosis of hydraulic circuit faults with flow ranges from 2 to 360 l/min.



Contact Information:

Parker Hannifin
Hydraulic Filter Division Europe

**European Product
Information Centre**
Freephone: 00800 27 27 5374
**(from AT, BE, CH, CZ, DE, EE, ES,
FI, FR, IE, IT, PT, SE, SK, UK)**
filtrationinfo@parker.com

www.parker.com/hfde

Product Features:

- LoFlow oil and water flowmeters. 10 bar max. working pressure.
- Easiflow meters and Flowswitches. Work in any plane. Flows from 1 to 150 l/min.
- Dataflow 4-20mA and pulse output flow transmitters and Dataflow Compact inline flow transmitter.
- Flowline oil, water and air calibrated flowmeters and flowswitches available in brass or Stainless Steel.
- Hydraulic Test Units for the speedy diagnosis of hydraulic circuit faults with flow ranges from 2 to 360 l/min.

LoFlow - Oil and Water Flowmeters

Flowmeters

Features & Benefits



- Easy to read, permanent printed scales.
- Large scale definition for precise measurement.
- Easy panel mounting assembly.
- Negligible pressure drop characteristics.
- 10 bar pressure rating.
- Simple to use.

Specification

Construction:
 Body Grillon TR55.
 Back body half ABS 7020.
 Ball retainer ABS 7020.
 Back panel PVC.
 Float See below.

Maximum working pressure:
 10 bar.

Maximum working temperature:
 60°C.

Accuracy:
 ±2% typical.

Repeatability:
 ±1%.

Connections:
 1/4" and 3/4" tapered threads.

Note: Always install vertically.

Installation Details

Simple to fit, easy to use

The LoFlow meter has been designed for those industries where the need exists for a low cost solution to small measurements of flow with an accurate reading. LoFlow uses the well tried and tested principle of variable area flow measurement utilising the movement of a ball or float inside a calibrated tapered bore.

Typical Applications

Pharmaceutical industry
 Filtration systems
 Hospital equipment
 For water applications

Water treatment
 Photography and X-ray
 Equipment
 Swimming pools

Installation Details

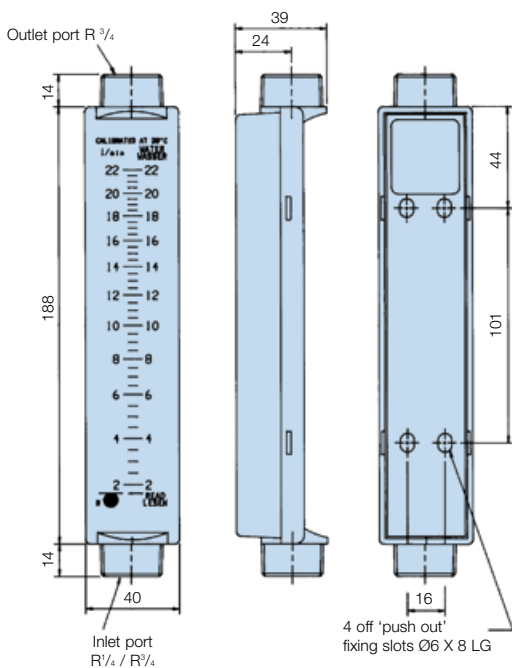

Ordering Information

Standard products table

Product number	Supersedes	Media	Ports (BSPT male)	Flow range (l/min)	Float material
LF802412	LF.2020	Water	3/4 - 3/4	0.2 - 2.0	Acetal
LF802413	LF.2100	Water	3/4 - 3/4	2.0 - 10.0	S/Steel
LF802414	LF.2220	Water	3/4 - 3/4	3.0 - 22.0	S/Steel
LF801431	LF.1002	Oil	1/4 - 3/4	0.010 - 0.20	S/Steel
LF802432	LF.1009	Oil	3/4 - 3/4	0.1 - 0.9	Acetal
LF802434	LF.1090	Oil	3/4 - 3/4	1.0 - 9.0	S/Steel
LF801411	LF.2005	Water	1/4 - 3/4	0.06 - 0.55	S/Steel

Note 1: Part numbers featured with bold highlighted codes will ensure a 'standard' product selection.

Note 2: Alternate displayed part number selection will require you to contact Parker Filtration for availability.

Easiflow - Meters and Flowswitches

Flowmeters

Features & Benefits



- Oil and water calibrated.
- Works in any plane.
- Pressures up to 10 bar.
- Flows from 1 to 150 l/min.
- Accuracy $\pm 5\%$ FSD.
- Repeatability $\pm 1\%$ FSD.
- Switches – fully adjustable flow rate signalling.
- Plant and equipment protection.



Easiflow Meters Specification

Construction:

Cone	Acetal
Viewing glass	Borosilicate glass
Calibrated spring	Stainless steel
Seal	Nitrile
Body	Glass filled nylon

Maximum working pressure:
10 bar.

Minimum working pressure:
1 bar.

Temperature range:
+5°C to +80°C - Oil.
+5°C to +60°C - Water.

Flow rate:

1 to 150 l/min.

Viscosity range:

10 to 200 centistokes (oil).

Accuracy:

$\pm 5\%$ FSD.

Repeatability:

$\pm 1\%$ FSD.

Connections:

1" BSP parallel threads.

Weight:

0.4kg.

Flowswitch Specifications

The Easiflow switch is a flow measuring device incorporating an AC/DC switch suitable for controlling valves or pump motors or for activating alarm signals.

General flowmeter specification:

See material details opposite.

Switch type specifications:

Magnetically operated reed switch.

Electrical details:

Voltage range	300Vac/dc
Maximum current	2.5Amps
Maximum load	100W resistive 70W inductive



Installation Details

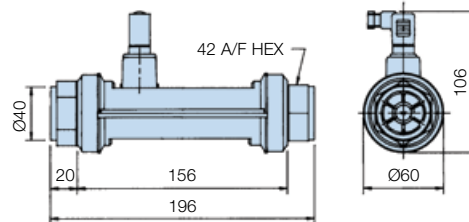
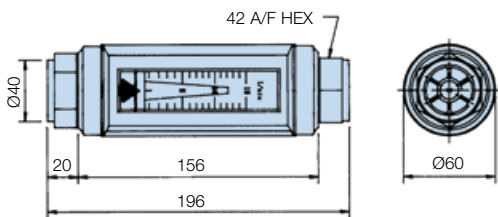

Ordering Information

Standard products table – Flowmeter only

Product number	Supersedes	Media	Flow range (l/min)
EF773111220	EFW.0302	Water	2 - 30
EF773111220	EFW.0502	Water	4 - 50
EF7731113220	EFW.1002	Water	5 - 100
EF7731114220	EFW.1502	Water	10 - 150
EF7731110120	EFL.0151	Oil	1 - 15
EF7731111120	EFL.0301	Oil	2 - 30
EF7731112120	EFL.0501	Oil	4 - 50
EF7731113120	EFL.1001	Oil	5 - 100
EF7731114120	EFL.1501	Oil	10 - 150
EF7731110220	EFW.0152	Water	1 - 15

Note 1: Part numbers featured with bold highlighted codes will ensure a 'standard' product selection.

Note 2: Alternate displayed part number selection will require you to contact Parker Filtration for availability.

Standard products table – Flowmeter plus one switch

Product number	Supersedes	Media	Flow range (l/min)	Switch range (l/min)
EF7731110221	ESW.015S1	Water	1 - 15	5 - 15
EF7731111221	ESW.030S1	Water	2 - 30	5 - 30
EF7731110121	ESL.015S1	Oil	1 - 15	5 - 15
EF7731111121	ESL.030S1	Oil	2 - 30	5 - 30
EF7731112121	ESL.050S1	Oil	4 - 50	10 - 50
EF7731113121	ESL.100S1	Oil	5 - 100	20 - 100
EF7731114121	ESL.150S1	Oil	10 - 150	30 - 150
EF7731112221	ESW.050S1	Water	4 - 50	10 - 50
EF7731113221	ESW.100S1	Water	5 - 100	20 - 100
EF7731114221	ESW.150S1	Water	10 - 150	30 - 150

Note 1: Part numbers featured with bold highlighted codes will ensure a 'standard' product selection.

Note 2: Alternate displayed part number selection will require you to contact Parker Filtration for availability.



Dataflow - 4 to 20mA and Pulse Output Flow Transmitters

Flowmeters

Features & Benefits



- 4 to 20mA output.
- Pulse output available for totalising/batching.
- Works in any plane.
- Accepts reverse flow.
- Maximum flow 150 l/min.
- Negligible pressure drop.
- Pressures up to 10 bar.
- Low cost. Simple to install.
- For use with most liquids.
- Factory calibrated. Accuracy $\pm 2\%$.
- DIN 43650 plug connection (included).

Specification

Construction:

Borosilicate glasstube.
Nitrile seals.
Body – Glass filled nylon.
Rotor and locater – Acetal.
Washers and shaft – Stainless steel.
Rotor tips – Stainless steel.

Max. working pressure:
10 bar oil/water.

Flow indication:
Min: 2 l/min.
Max: 150 l/min.
Accepts reverse flow.

Accuracy:
 $\pm 2\%$ FSD.

Temp range:
+5°C to +80°C oil.
+5°C to +60°C water.

Connections:

1" BSP parallel threads.

Weight:
0.7Kg.

Calibration 4 to 20mA:

4mA = 0 l/min,
20mA = 100 l/min.

Calibration pulse output per litre:

'K' factors.
Oil = 51.14
Water = 44.25

Electrical details 4 to 20mA:

Supply = 24Vdc.

Pulse output:

Supply = 24Vdc.
(open collector transistor).



Installation Details

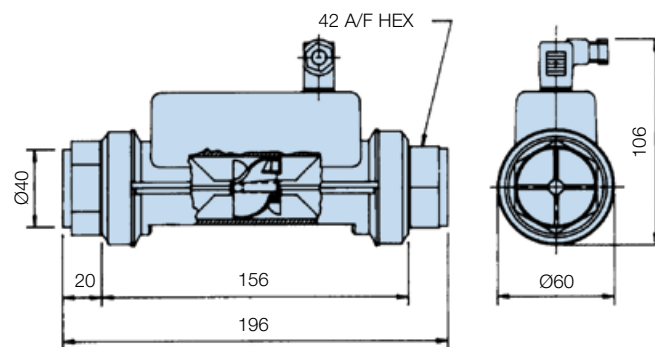

Ordering Information

Standard products table

Product number	Supersedes	Description
DFT980	DFT.980	Dataflow "Pulse" output transmitter
DFT990	DFT.990	Dataflow 4-20mA transmitter

Note 1: Part numbers featured with bold highlighted codes will ensure a 'standard' product selection.
Note 2: Alternate displayed part number selection will require you to contact Parker Filtration for availability.



Dataflow 4-20mA transmitter can be connected to a Digital Display Unit (DDU1001 or DDU1002)

Digital Display Specification (DFT 990 only)

For indicator options please refer to MS150 section of the catalogue, reference DDU1001 and DDU1002 indicators

4 to 20mA On-Site Calibration

Set your system to zero flow. Connect a multimeter across terminals 1 (+20mA) and \ominus (0mA) (Dia. 2). Set the zero to read 4mA on your multimeter (Dia. 1). Set your system to full flow and set the span to read 20mA on your multimeter. (Dia. 1)

Note: Minimum span setting = 30 l/min

Diagram 1

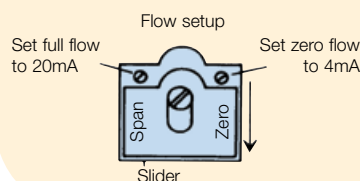
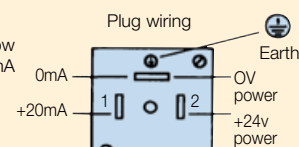

Diagram 2



Dataflow Compact - Inline Flow Transmitter

Flowmeters

Features & Benefits



- Pulse output signal for flows up to 25 l/min.
- Lightweight and robust.
- Operates in any plane. Simple to install.
- Low cost flow measurement.
- Negligible pressure drop.
- Accepts reverse flow.
- $\frac{3}{8}$ BSP male connection.
- Water or compatible clear fluids only.
- Ideal for washing machines, showers and vending machines.

Specification

Construction:

Body Grilamid – TR55.
Rotor 18% PTFE filled nylon.
Shaft Stainless steel.
Shaft Retainers Grilamid TR55.

Operation:

Infra-red.

Maximum working pressure:
20 bar.

Pressure drop:
Max 0.1 bar at 15 l/min.

Flow range:
1 to 25 l/min.
(Accepts reverse flow).

Calibration:
'K' Factor 752 pulses per litre, typical.
Subject to application.

Accuracy:
±2% typical.



Repeatability:

±1%.

Temperature range:
+5°C to +70°C.

Overall dimensions:
52mm x 29mm x 27mm.

Weight:
16 grams.

Connections:
 $\frac{3}{8}$ BSP

Cable length:
300mm.

Power supply:
5 Vdc.

Output signal:
5 Vdc - square wave

Dataflow Compact – The Low Cost Transmitter

The Dataflow Compact Transmitter was designed to offer OEM's and end users alike a means of monitoring low flows on liquids with an electronic output signal – but at LOW COST. Fluid passes through the one piece sensor body impacting on the twin vaned turbine rotor, causing it to rotate at a speed proportional to the flow rate. Two opposing photo-transistors are mounted either side of the rotor and externally of the clear sensor body, these generate a continuous signal.

As the rotor spins each blade obscures the infra red signal. This is then converted into an industry standard pulse output signal – compatible with inexpensive display units for flow rate, totalising, batch control and large, central control systems. The lightweight Grilamid body with its virtually unrestricted flow path, offers negligible pressure drop for flows up to 25 l/min and withstanding pressures up to 20 bar.

Flow Rate • Totalising • Batch Control and applications in many industries

Dataflow Compact Transmitters are small and very robust having been developed and tested extensively in industry applications where space is a restriction. Dataflow Compact with its Grilamid body and BSP connections can be installed almost anywhere and once installed will give accurate and reliable output signalling.

Installation Details

Red wire +5V supply
Green wire Output signal
Blue wire 0V supply

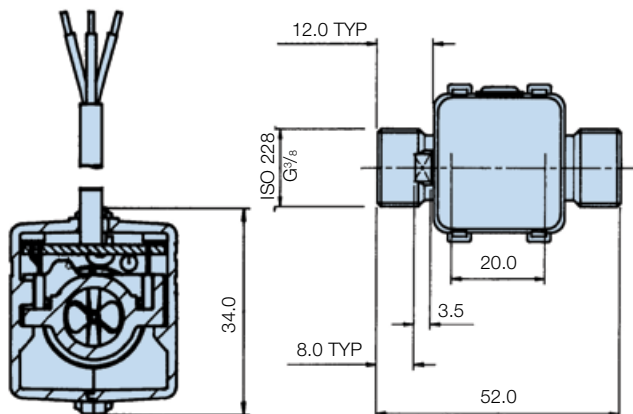

Ordering Information

Standard products table

Product number	Supersedes	Description
DFC9000100	DFC.9000.100	Dataflow compact flow transmitter

Note 1: Part numbers featured with bold highlighted codes will ensure a 'standard' product selection.
Note 2: Alternate displayed part number selection will require you to contact Parker Filtration for availability.



Flowline - Oil and Water Calibrated Flowmeters (Brass Version)

Flowmeters

Features & Benefits



- Works in any plane.
- Pressure up to 350 bar (5000 psi).
- Flows up to 360 l/min.
- Accuracy $\pm 5\%$ FSD.
- Repeatability $\pm 1\%$ FSD.
- Direct reading.
- Relatively insensitive to viscosity changes.
- Oil or water calibrated.
- Optional reed switch upgrade.

Specification

Construction:
Brass body to BS 2874 CZ114.

Maximum working pressure:
Up to 350 bar.

Minimum working pressure:
1 bar.

Temperature range:
Brass -20°C to $+90^{\circ}\text{C}$.

Calibration:
Oil Specific gravity 0.856 at 20°C .
Water Specific gravity 1.0 at 20°C .

Viscosity range:
10 to 200 cSt (oil).

Accuracy:
 $\pm 5\%$ FSD.

Repeatability:
 $\pm 1\%$ FSD.

Min. scale reading:
10% FSD.

Connections:
BSP parallel threads.

Wetted/non-wetted parts:
Consult Parker for information.

1/4", 1/2" and 3/4" BSP thread options
(1 1/4" version on next page)

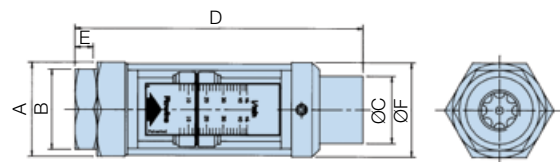

Note: To add an electrically operated reed switch to your flowmeter please order B26307

Ordering Information - Oil

Standard products table

Brass flowmeter for oil		Ports BSP	Flow range (l/min)	Maximum pressure (bar)	Dimensions (mm)						Weight (kg)
Product number	Supersedes				A (A/F Hex)	B (A/F Hex)	C	D	E	F	
FM26122212	FM.26 122 212	1/4	0.5 - 4.5	350	32	29	19	123	7	32	0.4
FM26122312	FM.26 122 312	1/4	1 - 9	350	32	29	19	123	7	32	0.4
FM26222112	FM.26 222 112	1/2	2 - 20	350	41	38	32	165.5	12.5	46	0.9
FM26222212	FM.26 222 212	1/2	5 - 46	350	41	38	32	165.5	12.5	46	0.9
FM26322112	FM.26 322 112	3/4	5 - 55	350	58	46	43	190	15	58	1.75
FM26322212	FM.26 322 212	3/4	10 - 110	350	58	46	43	190	15	58	1.75
FM26122112	FM.26 122 112	1/4	0.2 - 2.0	350	32	29	19	123	7	32	0.4
FM26422112	FM.26 422 112	1 1/4	20 - 180	210	For installation details for 1 1/4" flowmeters see next page						8.0
FM26422212	FM.26 422 212	1 1/4	30 - 270	210							8.0
FM26422312	FM.26 422 312	1 1/4	40 - 360	210							8.0

Ordering Information - Water

Standard products table

Brass flowmeter for water		Ports BSP	Flow range (l/min)	Maximum pressure (bar)	Dimensions (mm)						Weight (kg)
Product number	Supersedes				A (A/F Hex)	B (A/F Hex)	C	D	E	F	
FM26222122	FM.26 222 122	1/2	2 - 20	350	41	38	32	165.5	12.5	46	0.9
FM26222222	FM.26 222 222	1/2	5 - 46	350	41	38	32	165.5	12.5	46	0.9
FM26322122	FM.26 322 122	3/4	5 - 55	350	58	46	43	190	15	58	1.75
FM26322222	FM.26 322 222	3/4	10 - 110	350	58	46	43	190	15	58	1.75
FM26122122	FM.26 122 122	1/4	0.2 - 2.0	350	32	29	19	123	7	32	0.4
FM26122222	FM.26 122 222	1/4	0.5 - 4.5	350	32	29	19	123	7	32	0.4
FM26122322	FM.26 122 322	1/4	1 - 9	350	32	29	19	123	7	32	0.4
FM26422122	FM.26 422 122	1 1/4	20 - 180	210	For installation details for 1 1/4" flowmeters see next page						8.0
FM26422222	FM.26 422 222	1 1/4	30 - 270	210							8.0
FM26422322	FM.26 422 322	1 1/4	40 - 360	210							8.0

Note 1: Part numbers featured with bold highlighted codes will ensure a 'standard' product selection.

Note 2: Alternate displayed part number selection will require you to contact Parker Filtration for availability.



Flowline - Oil and Water Calibrated Flowmeters (Stainless Steel)

Flowmeters

Features & Benefits



- For flow measurement of corrosive or chemical media or in harsh locations.
- Manufactured in stainless steel 316.
- Works in any plane.
- Pressure up to 350 bar (5000 psi).
- Flows up to 360 l/min.
- Accuracy $\pm 5\%$ FSD.
- Repeatability $\pm 1\%$ FSD.
- Direct reading.
- Oil or water calibrated.
- Optional reed switch upgrade.

1 1/4" BSP option
(1/4", 1/2" and 3/4" on previous page)

Specification

Construction:
Stainless steel to BS 970 316S.

Maximum working pressure:
Up to 350 bar.

Minimum working pressure:
1 bar.

Temperature range:
-20°C to +105°C.

Calibration:
Oil Specific gravity
0.856 at 20°C.
Water Specific gravity
1.0 at 20°C.

Viscosity range:
10 to 200 cSt (oil).

Accuracy:
 $\pm 5\%$ FSD.

Repeatability:
 $\pm 1\%$ FSD.

Min. scale reading:
10% FSD.

Connections:
BSP parallel threads.

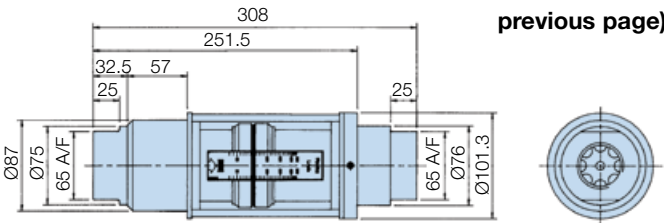

Wetted parts:
Body, thread adaptor

Piston, etc: cone locknut:
Stainless Steel.

Flow cone:
BS 970 316S 16.

Magnet encapsulation:
Stainless steel BS970/1:1991.
:316S31.

Spring:
Stainless steel to BS 2056 EN 58J.

Seal:
Fluoroelastomer.

Note: To add an electrically operated reed switch to your flowmeter please order B26307

Ordering Information - Oil

Standard products table

Stainless steel flowmeter for oil		Dimensions (mm)									Weight (kg)
Product number	Supersedes	Ports BSP	Flow range (l/min)	Maximum pressure (bar)	A (A/F Hex)	B (A/F Hex)	C	D	E	F	
FM26232112	FM.26 232 112	1/2	2 - 20	350	41	38	32	165.5	12.5	46	0.9
FM26332112	FM.26 332 112	3/4	5 - 55	350	58	46	43	190	15	58	1.75
FM26332212	FM.26 332 212	3/4	10 - 110	350	58	46	43	190	15	58	1.75
FM26132112	FM.26 132 112	1/4	0.2 - 2.0	350	32	29	19	123	7	32	0.4
FM26132212	FM.26 132 212	1/4	0.5 - 4.5	350	32	29	19	123	7	32	0.4
FM26132312	FM.26 132 312	1/4	1 - 9	350	32	29	19	123	7	32	0.4
FM26232212	FM.26 232 212	1/2	5 - 46	350	41	38	32	165.5	12.5	46	0.9
FM26432112	FM.26 432 112	1 1/4	20 - 180	350	For intallation details for 1 1/4 flowmeters see above					8.0	
FM26432212	FM.26 432 212	1 1/4	30 - 270	350						8.0	
FM26432312	FM.26 432 312	1 1/4	40 - 360	350						8.0	

Ordering Information - Water

Standard products table

Stainless steel flowmeter for water		Dimensions (mm)									Weight (kg)
Product number	Supersedes	Ports BSP	Flow range (l/min)	Maximum pressure (bar)	A (A/F Hex)	B (A/F Hex)	C	D	E	F	
FM26132122	FM.26 132 122	1/4	0.2 - 2.0	350	32	29	19	123	7	32	0.4
FM26132222	FM.26 132 222	1/4	0.5 - 4.5	350	32	29	19	123	7	32	0.4
FM26132322	FM.26 132 322	1/4	1 - 9	350	32	29	19	123	7	32	0.4
FM26232122	FM.26 232 122	1/2	2 - 20	350	41	38	32	165.5	12.5	46	0.9
FM26232222	FM.26 232 222	1/2	5 - 46	350	41	38	32	165.5	12.5	46	0.9
FM26332122	FM.26 332 122	3/4	5 - 55	350	58	46	43	190	15	58	1.75
FM26332222	FM.26 332 222	3/4	10 - 110	350	58	46	43	190	15	58	1.75
FM26432122	FM.26 432 122	1 1/4	20 - 180	350	For intallation details for 1 1/4 flowmeters see above					8.0	
FM26432222	FM.26 432 222	1 1/4	30 - 270	350						8.0	
FM26432322	FM.26 432 322	1 1/4	40 - 360	350						8.0	

Note 1: Part numbers featured with bold highlighted codes will ensure a 'standard' product selection.

Note 2: Alternate displayed part number selection will require you to contact Parker Filtration for availability.



Flowline - Flowswitches

Flowmeters

Features & Benefits



- ‘Boxed’ two-switch type.
- Intrinsically safe versions (supplied complete with flowmeter).
- Maximum/minimum switching models.
- Maximum working pressure 350 bar. (min 1 bar)
- Flows from 2.0 to 110 l/min.
- Stainless steel – suitable for corrosive fluids.
- Stainless steel to BS970 316516.

Ordering Information

To order the required switching unit, simply add the appropriate prefix before the part numbers shown below.

Standard products table

Product number	Supersedes	Description	Switch Range (Typical)
FS643222112	FS.643 222 112	2 switches, 2 - 20 l/min (1/2 BSP) Oil	2 -12 l/min and 10-20 l/min
FS643222212	FS.643 222 212	2 switches, 5 - 46 l/min (1/2 BSP) Oil	6-24 l/m and 20-46 l/m
FS643322112	FS.643 322 112	2 switches, 5 - 55 l/min (1/4 BSP) Oil	5-30 l/min and 30-55 l/min
FS643322212	FS.643 322 212	2 switches, 10 - 110 l/min (1/4 BSP) Oil	10-50 l/min and 50-110 l/min

Product configurator

Brass flowswitch for oil or water		Flow range and (port size)		Fluid type		Switch Range (Typical)
Product number						
FS643	2 switches	2221	2 - 20 l/min (1/2 BSP)	12	Oil	2 -12 l/min and 10-20 l/min
FS67A	Intrinsically safe high switch	2222	5 - 46 l/min (1/2 BSP)	22	Water	20-24 l/m
FS67B	Intrinsically safe low switch	3221	5 - 55 l/min (1/4 BSP)			5-30 l/min
FS67C	Intrinsically safe hi/low switch	3222	10 - 110 l/min (1/4 BSP)			10-50 l/min and 50-110 l/min

Product configurator

Stainless steel flowswitch for oil or water		Flow range and (port size)		Fluid type		Switch Range (Typical)
Product number						
FS643	2 switches	2321	2 - 20 l/min (1/2 BSP)	12	Oil	2 -12 l/min and 10-20 l/min
FS67A	Intrinsically safe high switch	2322	5 - 46 l/min (1/2 BSP)	22	Water	24-46 l/m
FS67B	Intrinsically safe low switch	3321	5 - 55 l/min (1/4 BSP)			5-30 l/min
FS67C	Intrinsically safe hi/low switch	3322	10 - 110 l/min (1/4 BSP)			10-50 l/min and 50-110 l/min

Ordering example

Product number	Supersedes
FS643332212	FS.643 332 212

Note 1: Part numbers featured with bold highlighted codes will ensure a 'standard' product selection.

Note 2: Alternate displayed part number selection will require you to contact Parker Filtration for availability.

Hydraulic Test Equipment

Flowmeters

Features & Benefits



- Speedy diagnosis of hydraulic circuit faults.
- Flows ranging from 2 to 360 l/min.
- Measuring flow, pressure and temperature.
- Fully Portable – No power source required.
- Hydrotrac unit for flows from 2 to 110 l/min available.
- Designed for oil applications only.

Specification

Flow range:
2 to 360 l/min.

Pressure range:
1 to 350 bar.

Temperature range:
0°C to +90°C.

Installation Details

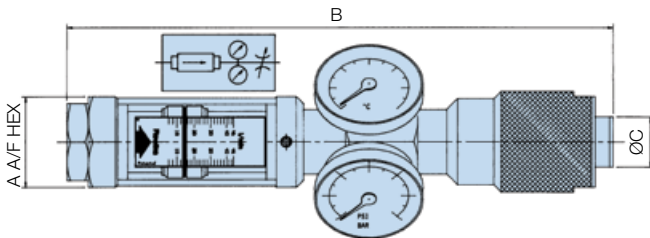

Safety

An axial flow restrictor valve is fitted which can be adjusted under full load from open to fully closed¹, and to complete the specification, a safety blow-out disc, set to fail at 455 bar is fitted to the manifold in a position facing away from the operator when reading the gauges normally. Two spare blow-out discs are supplied which are easily replaced by removing the hexagonal plug on the gauge manifold.

Additional blow out discs can be ordered - 41203B (Bag of 10)

Ordering Information

Standard products table

Product number	Flow range (l/min)	Weight Kg (with case)	Dimensions (mm)		
			A	B	C
4121	10 - 110	7.4	46	350	35
4120	5 - 55	7.4	46	350	35
4123	2 - 110	11.8	46	350	35
4168	20 - 180	13.85	75	496	87
4169	30 - 270	13.85	75	496	87
4170	40 - 360	13.85	75	496	87
Part number	Supersedes	Description			
41203B	4120.3.B	Safety blow out discs x 10			

Note 1: Part numbers featured with bold highlighted codes will ensure a 'standard' product selection.

Note 2: Alternate displayed part number selection will require you to contact Parker Filtration for availability.

Note 3: 4123 'Hydrotrac' unit features 2 flowmeters (2 - 20 and 10 - 110 l/min) and 1 pressure gauge and 1 thermometer.

Troubleshooting Test Units

Hydraulic Test Units are designed specifically for the speedy diagnosis of hydraulic circuit faults in mobile, marine and industrial systems using the normal range of mineral oils. Their rugged construction based mainly on mild steel, manganese bronze and acrylic materials makes them ideally suited for arduous use in the field.

Each unit is supplied in a convenient carrying case providing full protection and additional storage space for fittings. Because they need no power source such as batteries etc, they are always ready for instant use.

6 models are available to cover flow capacities up to 360 l/min and each incorporates a direct reading, uni-directional flow meter. The meter, which is both self cleaning and reasonably tolerant of contaminated fluids is coupled to a manifold that houses a glycerine-filled pressure gauge calibrated 0 to 350 bar and a dial-type thermometer with a 0°C to 100°C range.

Unit can only operate up to 90°C.

For further convenience the scale on the flow meter can be rotated to ensure visibility in any situation and the installed attitude of the assembly is not critical, though whenever possible the unit should be mounted with pressure gauge vertical and gauge case relief valve uppermost. The unit is designed for flow to be in the direction of the arrow on the flowmeter scale and must not be installed with the flow reversed.

¹ Note: Permissible allowed see page <50ml/min at 350 bar (5076 psi)

Flow Products - For Compressed Air Applications

Flowmeters & Monitors

Features & Benefits



Ⓐ Flowline Flowswitches and Flowmeters

- Calibrated for direct reading of compressed air at 7 bar.
- Works in any plane.
- Brass or stainless steel models available in 4 sizes.
- Calibrated at 7 bar and 20°C.
- Flow ranges from 2 to 600 SCFM.
- Pressure 1-41 bar max.
- Optional reed switch upgrade.

Ⓑ Loflow Air Flowmeters

- Flow measurement from 1.1 to 720 l/min. Max 10 bar rating.

Ⓒ Compressed Air Test Equipment

- 6 models available – 1/4", 3/4" and 1 1/4" BSP.
- Air flow range 2 to 600 SCFM.
- Pressure 1-41 bar max.

Specification

Full technical specifications for the Flowmeter, Flowswitch, LoFlow and test equipment products are provided in the respective pages for these products.

Ordering Information

Standard products table

Brass flowmeter for air		Ports BSP	Flow range		Maximum working pressure (bar)
Product number	Supersedes		SCFM	l/sec	
FM26123332	FM.26 123 332	1/4	2 - 20	1 - 10	41
FM26223132	FM.26 223 132	1/2	5 - 50	2 - 25	41
FM26223232	FM.26 223 232	1/2	10 - 110	5 - 50	41
FM26323132	FM.26 323 132	3/4	15 - 125	6 - 60	41
FM26323232	FM.26 323 232	3/4	20 - 225	10 - 100	41
FM26423132	FM.26 423 132	1 1/4	40 - 400	20 - 200	25
FM26423232	FM.26 423 232	1 1/4	60 - 600	30 - 300	25

Standard products table - LoFlow

Product number	Supersedes	Ports (BSPT male)	Flow range	Float material
LF801450	LF.3007E	1/4 - 3/4	1.1 - 8.0 l/min	Acetal
LF802455	LF.3050E	3/4 - 3/4	10 - 50 l/min	Acetal
LF802452	LF.3135E	3/4 - 3/4	20 - 135 l/min	Acetal
LF802454	LF.3720E	3/4 - 3/4	2 - 12 l/sec	S/Steel
LF801451	LF.3021E	1/4 - 3/4	4 - 22 l/min	S/Steel
LF802453	LF.3330E	3/4 - 3/4	1.0 - 5.5 l/sec	S/Steel

Standard products table

Stainless steel flowmeter for air		Ports BSP	Flow range		Maximum working pressure (bar)
Product number	Supersedes		SCFM	l/sec	
FM26133332	FM.26 133 332	1/4	2 - 20	1 - 10	41
FM26233132	FM.26 233 132	1/2	5 - 50	2 - 25	41
FM26233232	FM.26 233 232	1/2	10 - 110	5 - 50	41
FM26333132	FM.26 333 132	3/4	15 - 125	6 - 60	41
FM26333232	FM.26 333 232	3/4	20 - 225	10 - 100	41
FM26433132	FM.26 433 132	1 1/4	40 - 400	20 - 200	41
FM26433232	FM.26 433 232	1 1/4	60 - 600	30 - 300	41

Product configurator

Brass flowswitch for air		Ports (BSP)	Fluid type
Product number	Flow range SCFM and (l/sec)		
FS643	2 switches	1/2	32 Air
FS67A	Intrinsically safe high switch	1/2	
FS67B	Intrinsically safe low switch	3/4	
		3/4	

Ordering example

Product number	Supersedes
FS643323232	FS.643 323 232

Note 1: Part numbers featured with bold highlighted codes will ensure a 'standard' product selection.
 Note 2: Alternate displayed part number selection will require you to contact Parker Filtration for availability.
 Note 3: To add an electrically operated reed switch to your flowmeter please order B.26307



Guide to Contamination Control

Understanding and Answering the Threat of Contamination



Reduce downtime with effective contamination monitoring

Understanding and answering the threat of contamination

Understanding the significance that solid and liquid contamination can play in undermining the efficiency and effectiveness of hydraulic oils is a complex subject but one that has some basic components and solutions as to how to monitor, measure and ultimately remove any particulate from a system. Parker Filtration can offer many years of experience on this subject.

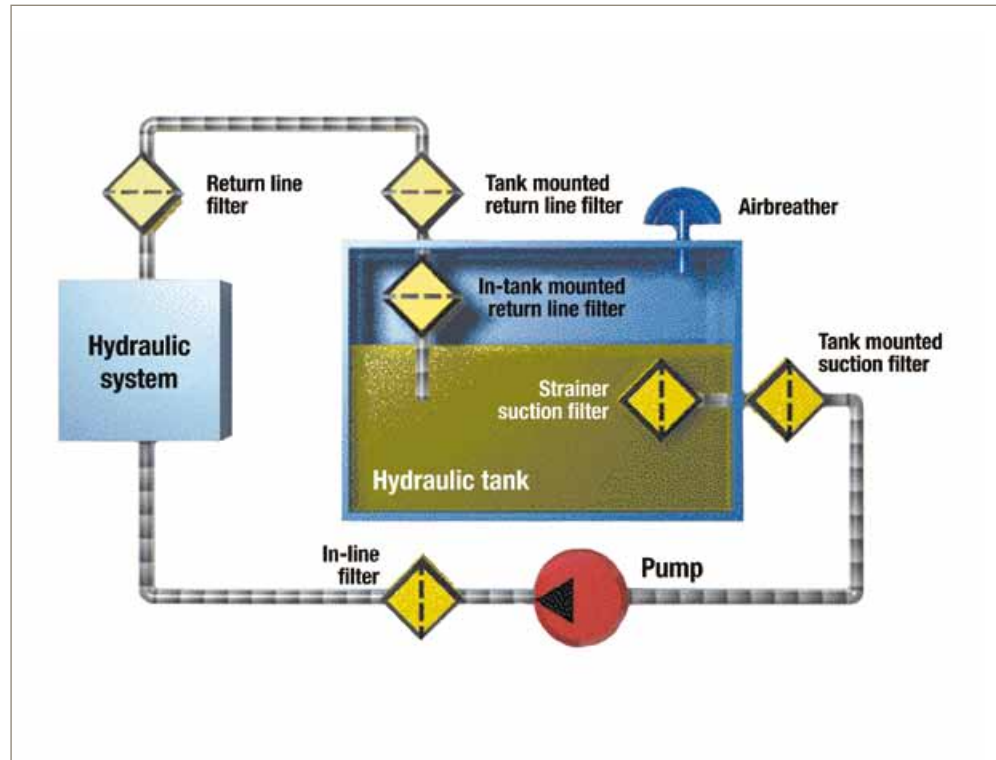

Contact Information:

Parker Hannifin
Hydraulic Filter Division Europe

European Product Information Centre
Freephone: 00800 27 27 5374
(from AT, BE, CH, CZ, DE, EE, ES, FI, FR, IE, IT, PT, SE, SK, UK)
filtrationinfo@parker.com

www.parker.com/hfde

Product Features:

- Examples and explanations of ISO contamination levels.
- Solid contamination codes charted.
- Condition monitoring equipment explained.
- Degree of filtration overview

Guide to Contamination Control

Understanding and Answering the Threat of Contamination

The Threat of Contamination

Industry requirements with regard to hydraulic and oil lubrication systems emphasise reliability, long lifetime and reduced energy use. Depending on the circumstances, some 70 - 80% of system failures are due to contamination. Cleanliness monitoring is essential in contamination control, as is selecting the right filter components. The first step, however, is understanding the specific system requirements and local operating conditions.

This guide to contamination control describes:

- Types of failures
- Sources of contamination
- Fluid cleanliness level
- Condition monitoring equipment
- Cleanliness service
- Filtration: parameters and facts
- Filter selection and filter types

Types of Failures

Component failure is often an invisible process. In general three types of failure can be distinguished:

1. Catastrophic Failures

This failure occurs suddenly and without warning; it is of a permanent nature. It is often caused by larger sized particles entering a component and obstructing the relative movement between surfaces, resulting in seizure of the component.

2. Transient Failures

Generally speaking, this type of failure is short-lived and goes unnoticed, although the consequences rarely do. It is caused by particles that momentarily interfere with the function of a component. The particles lodge in a critical clearance between matching parts, only to be washed away during the next operation cycle. As a result, components become less predictable and thus unsafe.

3. Degradation Failures

Gradual deterioration in the performance of a component results in its eventual repair or replacement. This failure is caused by the effect of wear induced by contamination. Additional generated contamination can lead to a catastrophic failure. Failures or reduced system performance have a direct impact on the cost of ownership, the efficiency rate and the perceived quality perception of the end users.



Sources of Contamination

Finding the balance

What does it take to implement system-matched filtration? A review of the sources of contamination is the first step in finding the balance between the performance of the filtration system and the system demands.

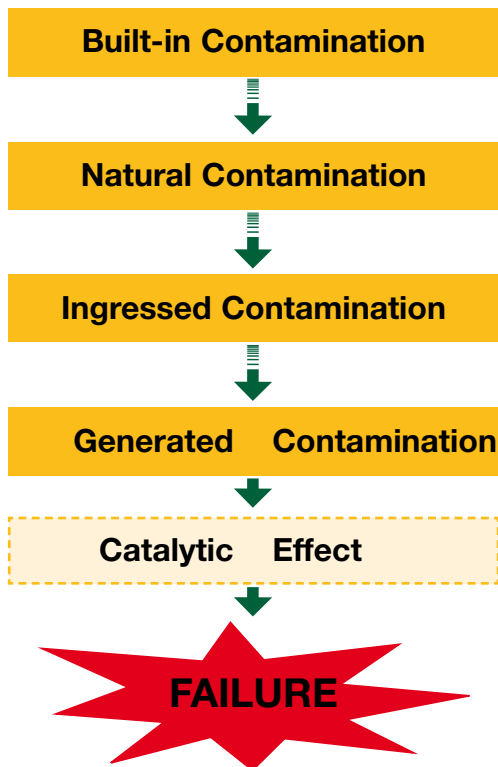

Sources of Contamination

Several sources of contamination must be taken into account when it comes to the effective implementation of system-matched filtration. Without adequate filtration, the protection of the system is jeopardised and component or system failure is imminent. System-matched filtration changes the deterioration into a balanced situation, representing the continuously controlled process that is needed to achieve system reliability. Realising this is only possible when the required fluid cleanliness levels are maintained.

1. Built-in Contamination

Residual contamination from the manufacturing and assembly processes cannot be avoided. Examples are machining debris, weld spatters, casting sand, paint, pipe sealant or fibres from cleaning rags. Flushing system components prior to assembly and decent housekeeping during the various stages of the assembly process are a must to reduce the amount of built-in contamination.



Filter media pleating

2. Natural Contamination

In general, the cleanliness level of new oil does not always meet the requirements of the system. Despite the efforts to control the fluid cleanliness level during the production processes, transport and distribution may contaminate the oil. Depending on the requirements for system cleanliness, we advise that you filter new oil before usage.

3. Ingressed Contamination

Systems are always under attack from contamination. Unfortunately it is not possible to avoid ingress contamination. Air breathers, cylinder rod seals, wiper seals, component seals or poorly fitted covers are a few examples of system parts that may have an important influence on the amount of ingress contamination.

4. Generated Contamination

Particles generate particles. This phenomenon is known as abrasion. Other processes like cavitation, corrosion, erosion, fatigue and metallic contact between moving parts generates particles and thus influences the contamination that is already present in the system. Even though these processes cannot always be avoided, their impact is strongly influenced by effective filtration.

5. Catalytic Effect

During the filter selection process, attention is generally given to the removal of solid, hard-type contamination only. The performance of hydraulic and lubrication fluids is influenced by the catalytic effect. As a result of the catalytic effect, the lifetime of the oil is significantly reduced.

Guide to Contamination Control

Understanding and Answering the Threat of Contamination

Lifetime of Oil

Selecting the Right Oil

Oils are selected based on their unique performance with regard to:

- a. Energy transfer
- b. Corrosion protection
- c. Cooling (transfer of heat)
- d. Lubrication

The lifetime of oils is influenced by the amount of oxygen, oil temperature, water content and presence of catalyser type elements. The allowed water content varies for each type of oil. Due to, for example, seal leakage or condensation, the water content can easily reach concentrations far above the allowed water content value. The combination of water and wear elements like iron or copper causes a catalytic effect and as a result, reduces the lifetime of the oil. The lifetime of oil is also influenced by the amount of generated static electrics.

Lifetime Reduction

The lifetime reduction of oil is expressed by the degradation factor. The influence of the catalytic effect of the degradation factor is shown below.

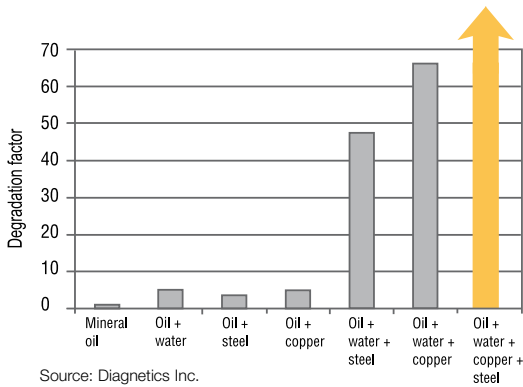

Oil degradation can reduce the protection against corrosion and lubrication performance.

Regular oil analysis is important to monitor the condition of the hydraulic or lubrication fluid. This analysis is also used to obtain information related to the process of selecting system-matched filter components.



Tanktopper II return line filter with integrated air breather and patented LEIF® element

The Balance between System Requirements and Filtration System Performance

Parker's philosophy exceeds the traditional approach of protecting the system by means of filtration.

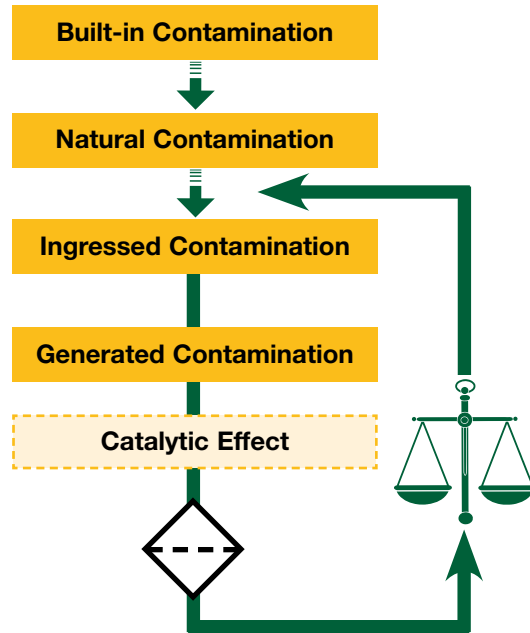

System-matched filtration is not limited to a filter alone. The process of system-matched filtration is based on the correct implementation of suitable filtration products, taking into account the requirements from the hydraulic or lubrication fluids, system components and customer expectations.

Contamination Control

Achieving the required system protection implicates a correct understanding of the system. Today filters are selected based on several parameters like β -values, pressure drop and dirt holding capacity.

Filtration is built-in safety, meant to achieve and maintain the required fluid cleanliness level during a defined period. This implicates a more detailed approach, which can only be realised when several filtration parameters are considered.

Before Filtration

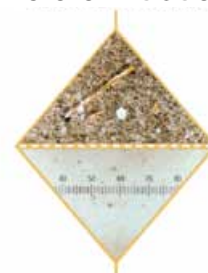

After Filtration

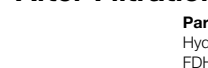

Parker Hannifin
Hydraulic Filter Division Europe
FDHB500UK/Guide

Contamination & Cleanliness Level

Sizes of Contamination

Filters are selected to capture contamination from hydraulic and lubrication fluids.

Contamination is an invisible enemy. The human eye cannot see particles smaller than 40 micron. For the correct understanding a comparison is given below.

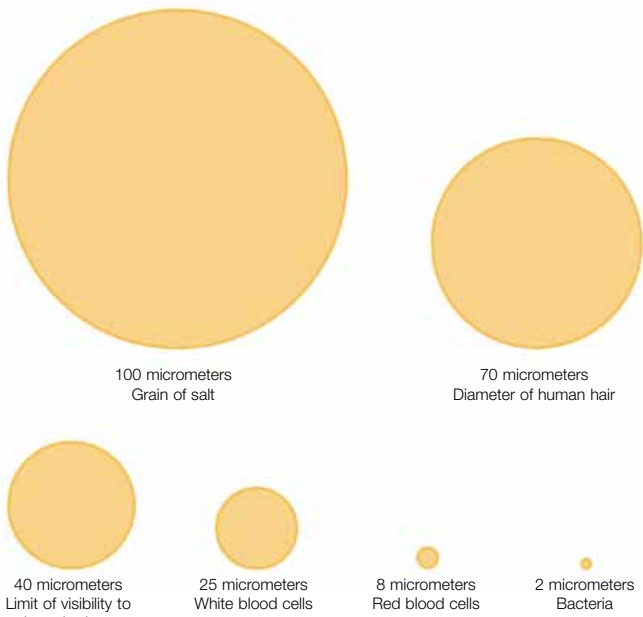

Component	Microns
Anti-friction bearings	0.5
Vane pump (vane tip to other ring)	0.5 - 1
Gear pump (gear to side plate)	0.5 - 5
Servo valves (spool to sleeve)	1 - 4
Hydrostatic bearings	1 - 25
Piston pump (piston to bore)	5 - 40
Servo valves flapper wall	18 - 63
Actuators	50 - 250
Servo valve orifice	130 - 450

Typical hydraulic component clearances are given as an indication only

Fluid Cleanliness Level

The ISO 4406:1999 standard is an important code to define the fluid cleanliness level using a solid contamination code.

This ISO code is determined by allocating a first scale number to the total number of particles larger than 4µm, allocating a second scale number to all particles larger than 6µm and allocating a third scale number to the total number of particles larger than 14µm.

In the recent past, the fluid cleanliness level code was determined using the ISO 4406:1987 standard. Instead of counting particles sizes 4, 6 and 14µm, the fluid cleanliness level was determined by counting particles larger than 5 and 15µm. The particle size 2µm was added later.

As a result of upgrading the ISO standards, new particle sizes have been defined. In general, the fluid cleanliness code will not change as a result of this new standard. Built-up historic data remains directly comparable to new data.

ISO 4406:1999 cleanliness classes

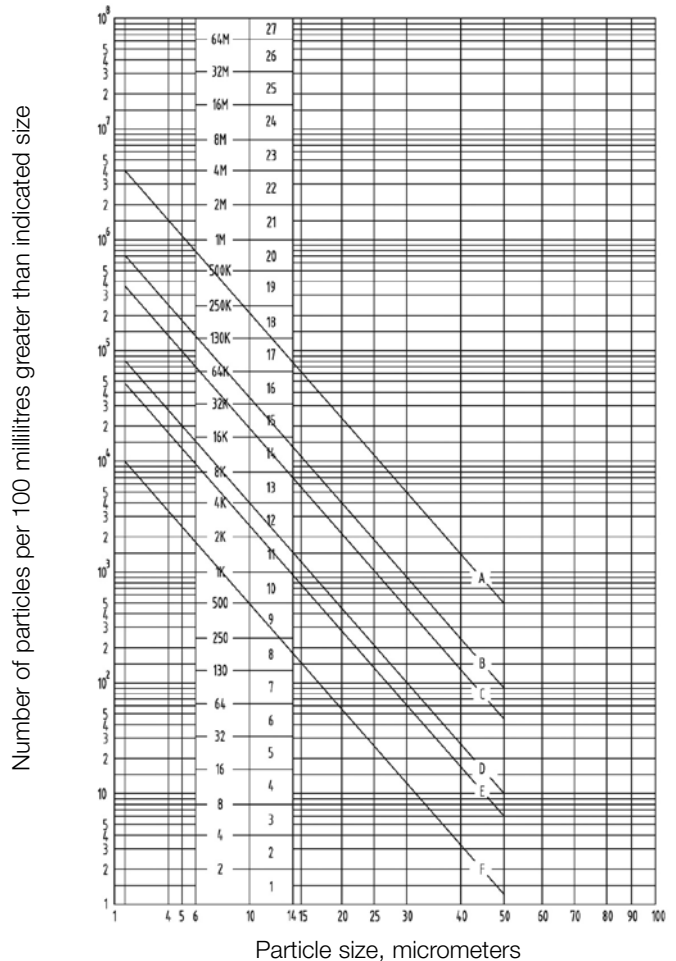

Guide to Contamination Control

Understanding and Answering the Threat of Contamination

Cleanliness Level

Examples of cleanliness level are given in the ISO graph. These lines represent:

- A. Low-pressure systems (code 21/20/17)
- B. Low-pressure control systems (code 19/18/14)
- C. Sophisticated pumps/motors control valves (code 18/17/13)
- D. Highly sophisticated systems and hydrostatic transmissions (code 16/15/11)
- E. Sensitive servo systems (code 15/14/10)
- F. High performance sensitive systems (code 12/11/8)

We recommend verifying the required cleanliness level based on the components used for the system. Manufacturers of system components often provide information related to the required fluid cleanliness level for their products.

Condition Monitoring Equipment

Over the years, fluid condition monitoring has become increasingly important. By offering system-matched filtration solutions, the stringent customer demands related to extended component lifetime or improved system reliability can be met. Parker has developed a complete range of instruments and components for maintenance programmes and local fluid condition analysis such as the LaserCM below.



Parker's particle counters are well known for their accurate performance in the field or in a production line environment. Lightweight portable particle counters can be used for temporary fluid cleanliness measurements.

The MCM20, designed for permanent installation, is meant for continuous fluid monitoring. The compact MS100 and MS150 moisture sensor means a complete solution is available to measure the water content in hydraulic or lubrication fluids.

Solid Contaminant Codes

In addition to ISO 4406: 1999, other standards are used to express the fluid cleanliness level. A comparison between the codes is given below.

ISO 4406: 1999	ISO 4406: 1987	NAS 1638 CLASS
13/11/8	11/8	2
14/12/9	12/9	3
15/13/10	13/10	4
16/14/9	14/9	-
16/15/11	14/10	5
17/15/9	15/9	-
17/15/10	15/10	-
17/15/12	15/12	6
18/16/10	16/10	-
18/16/11	16/11	-
18/16/13	16/13	7
19/17/12	17/12	-
19/17/14	17/14	8
20/18/12	18/12	-
20/18/13	18/13	-
20/18/15	18/15	9
21/19/13	19/13	-
21/19/16	19/16	10
22/20/13	20/13	-
22/20/17	20/17	11

Note:
 ISO 4406: 1987 is based on particle sizes larger than 5 and 15µm
 ISO 4406: 1999 is based on particle sizes larger than 4, 6 and 14µm

Several Cleanliness Levels

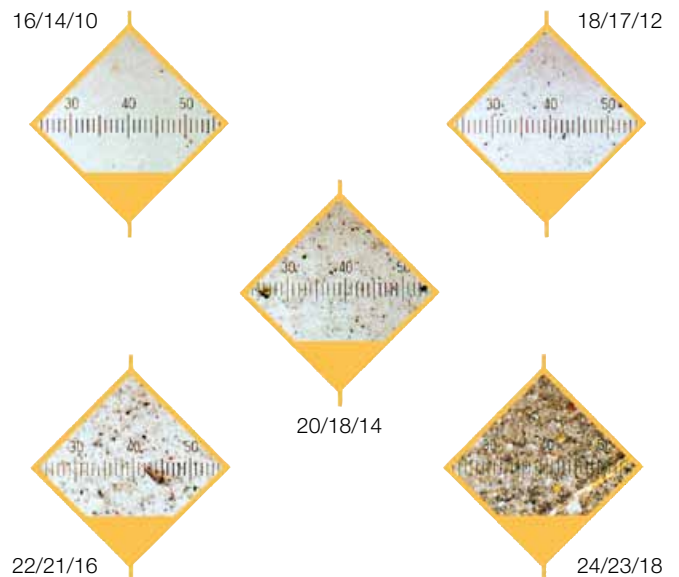

Cleanliness Service

Cleanliness Service to Prevent Failures

As Parker has no financial interest in the oil industry, the company can operate as an independent laboratory. The development laboratory at Parker Filtration BV in Arnhem - the only laboratory of its kind in Belgium, the Netherlands and Luxembourg - has at its disposal all the facilities for its extensive R & D department. In addition, the services are offered on a commercial basis to third parties.

Equipment

The laboratory uses state-of-the-art test equipment. The company has invested in the latest Karl Fischer coulometric equipment, that prevents tests from being influenced by, among other things, additives in the oil. The particle-counting equipment is calibrated according to the recent ISO 11171 standard. It is now possible to indicate the measured cleanliness according to ISO 4406:1999.

Standard Test

The high-quality standard test, carried out in Parker's laboratory, consists of a water analysis and a cleanliness calculation according to ISO 4406, the new ISO 4406:1999 and the NAS 1638 standard, as part of which particles from 2 to 100µm are measured and reported. Membrane research and digital photography of the membrane are also part of the standard test. The results of each test are described in a report that contains clear conclusions. It is also possible to conduct a spectral analysis.

In Practice

How do the laboratory services work? Only three days after receipt of the oil sample, the standard analysis is completed. The results of a spectral analysis are known after seven days. The reports can be sent directly and completely by e-mail. A free sample bottle is available upon request.

Filtration: Parameters and Facts

Generally speaking, fibre-type materials like cellulose and glass fibre are applied for hydraulic and lubrication fluid filtration. Filters are selected based on the following parameters:

- Required protection of system components
- Location of filter(s) in the system
- Flow rate and allowed pressure loss
- Desired filter element life time
- Hydraulic or lubrication fluid type

The dirt holding capacity is the amount of solid contamination a filter can hold before the filter material is plugged. This value is measured in accordance to ISO 16889 using ISO MTD test dust. The filter element lifetime strongly depends on the contamination conditions that are present in the system and its environment.

Predicting the filter element lifetime in the system is complicated, because of the variety in contamination (e.g. metal, sand and fibres, each with a certain distribution of particle sizes) in relation to the specified dirt holding capacity.

Degree of Filtration

Parker's filtration philosophy is based on the optimum distribution of several particle sizes by using the complete thickness of glass fibre layers.

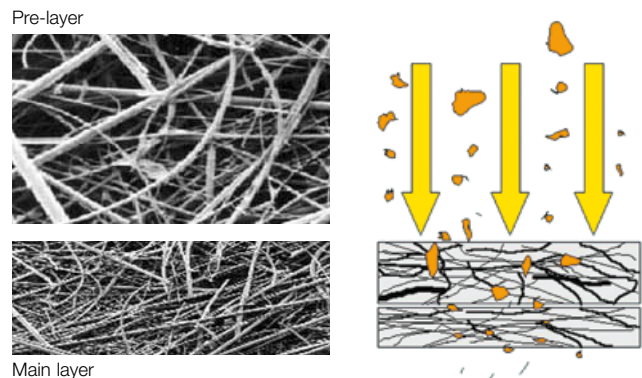

Each selected filter layer has a unique performance for the removal of solid contamination. System-matched filtration implicates the removal of harmful particles. For some systems an improved removal efficiency for smaller sized particles is more important compared to other systems using components. The combination of pre- and main layers results in an achievable fluid cleanliness level. The complete package of filter and support layers is indicated as pleat pack.