



Cylinder Control Accessories Exhaust Silencers

*Catalogue no. PDE2566TCUK-ev
Edition : January 2007*



Cylinder Control Accessories

4 - 26

Exhaust Silencers

27 - 35

 **WARNING**

FAILURE OR IMPROPER SELECTION OR IMPROPER USE OF THE PRODUCTS AND/OR SYSTEMS DESCRIBED HEREIN OR RELATED ITEMS CAN CAUSE DEATH, PERSONAL INJURY AND PROPERTY DAMAGE.

This document and other information from Parker Hannifin Corporation, its subsidiaries and authorized distributors provide product and/or system options for further investigation by users having technical expertise. It is important that you analyze all aspects of your application and review the information concerning the product or system in the current product catalog. Due to the variety of operating conditions and applications for these products or systems, the user, through its own analysis and testing, is solely responsible for making the final selection of the products and systems and assuring that all performance, safety and warning requirements of the application are met. The products described herein, including without limitation, product features, specifications, designs, availability and pricing, are subject to change by Parker Hannifin Corporation and its subsidiaries at any time without notice.

SALE CONDITIONS

The items described in this document are available for sale by Parker Hannifin Corporation, its subsidiaries or its authorized distributors. Any sale contract entered into by Parker will be governed by the provisions stated in Parker's standard terms and conditions of sale (copy available upon request).

		Page n°
Overview		4 - 5
Speed/Flow control	PTFL4/8PB	6
	PTF4/8PB	7
	PTF4/8E6PB	8
	PWR-L	9
Micrometer flow control	33**	10
Heavy duty inline flow control valves	3250	11 - 12
Speed flow control valves	VQB	13 - 14
Blockers and blocker/flow regulators	PWB	15
	PWR-HB	15
Quick exhaust valves	P4Q	17
Shuttle valves	...5	18
Back pressure sensors	PWS	19 -20
Optimisers	PWP	21
Soft start	PWD	22
Non return valves - Male thread	3047	23
Female	VB	24
Push-in	PWA	25
Terminal block sub-bases	PZC-B	26

Cylinder control accessories

Speed/flow controllers

Blockers

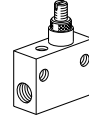
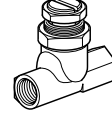
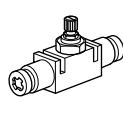
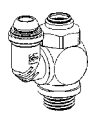

PTFL8

PTF8

PTF8E6

PWR-L

33

3250

VQB

PWB

Symbol

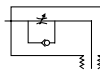

Body material:

Metal



Thermoplastic



Mounting:

On cylinder



In line



Panel



On valve

Adjustment:

By tool



By hand



Micrometer adjustment



Sizes

1

3/4

1/2

3/8

1/4

1/8

M5

12 mm

10 mm

8 mm

6 mm

4 mm

Refer to page

6

7

8

9

10

11 - 12

13 - 14

15 - 16

- For direct mounting on to cylinder
- Allen key adjustment
- Push-in connection
- Wide range of sizes



Operating and additional information

Operating pressure: 1 to 10 bar
 Operating temperature: -25°C to +100°C
 Sealing device: M5 Nylon washer
 1/8 - 1/2 BSPP Nitrile E.D. seal
 Terminations: 4mm - 12mm push-in connection
 6mm - 12mm - compression connection
 Maximum connecting torque: M5= 0,5Nm ; 1/8=9Nm ; 1/4=15Nm ; 3/8=22Nm ; 1/2=42Nm
 Body material: Brass black epoxy coated
 Lock nut: Brass

PTFL4/8PB - Flow regulator with push-in connection

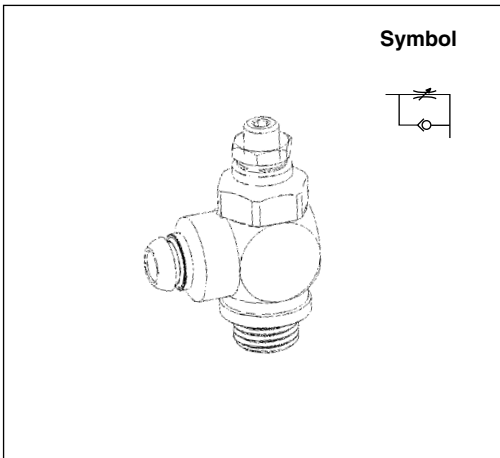

Thread	Port thread	Number of turns	Qmax input at 6 bar, l/min*	Weight kg	Order code
M5x0,8	4	19	33,4	0,015	PTFL8PB4M5**
G1/8	4	18	105	0,042	PTFL4PB4-1/8
M5x0,8	6	19	36	0,019	PTFL8PB6M5**
G1/8	6	18	160	0,044	PTFL4PB6-1/8
G1/4	6	12,5	360	0,074	PTFL4PB6-1/4
G3/8	6	17	440	0,147	PTFL4PB6-3/8
G1/8	8	18	160	0,064	PTFL4PB8-1/8
G1/4	8	12,5	355	0,079	PTFL4PB8-1/4
G3/8	8	17	720	0,152	PTFL4PB8-3/8
G1/4	10	12,5	380	0,076	PTFL4PB10-1/4
G3/8	10	17	835	0,138	PTFL4PB10-3/8
G1/2	10	21	974	0,224	PTFL4PB10-1/2
G3/8	12	17	805	0,143	PTFL4PB12-3/8
G1/2	12	21	1284	0,225	PTFL4PB12-1/2

* Screw closed
 ** These fittings are supplied with Nylon seal

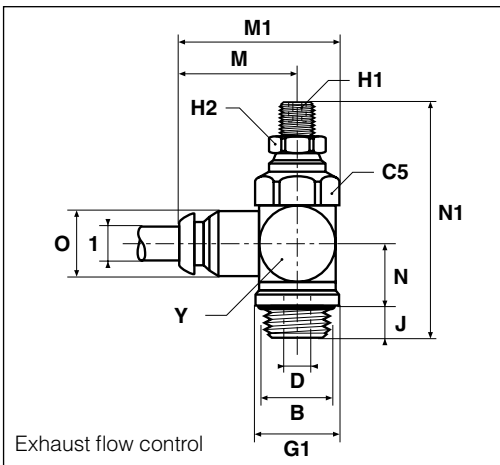

Order code	C5	D	G1	H1	H2	J	M	M1	N	N1	O	Y
PTFL8PB4M5**	8	1,65	10,0	1,5	8	4	19,5	24,5	6,3	28,5	10	10
PTFL4PB4-1/8	14	3,00	14,4	2,0	7	6	22,0	30,1	10,7	43,7	10	14
PTFL8PB6M5**	8	1,65	10,0	1,5	8	4	20,5	26,5	7,3	31,0	12	12
PTFL4PB6-1/8	14	3,20	14,4	2,0	7	6	23,5	31,6	10,7	43,7	12	14
PTFL4PB6-1/4	17	5,20	18,4	4,0	11	7	25,0	34,9	13,8	51,8	12	17
PTFL4PB6-3/8	22	5,50	21,6	4,0	11	7	28,0	40,7	17,3	63,7	12	22
PTFL4PB8-1/8	14	3,20	14,4	2,0	7	6	25,0	33,1	10,7	43,7	14	14
PTFL4PB8-1/4	17	5,20	18,4	4,0	11	7	28,5	38,3	13,8	51,8	14	17
PTFL4PB8-3/8	22	6,00	21,6	4,0	11	7	29,5	42,2	17,3	63,7	14	22
PTFL4PB10-1/4	17	5,20	18,4	4,0	11	7	31,5	41,3	13,8	51,8	17	17
PTFL4PB10-3/8	22	6,00	21,6	4,0	11	7	34,0	46,7	17,3	63,7	17	22
PTFL4PB10-1/2	27	8,00	26,5	4,0	14	9	36,5	52,1	20,1	76,1	17	27
PTFL4PB12-3/8	22	6,00	21,6	4,0	11	7	34,0	46,7	17,3	63,7	20	22
PTFL4PB12-1/2	27	8,50	26,5	4,0	14	9	36,5	52,1	20,1	76,1	20	27

Exhaust flow control



- For direct mounting on to cylinder
- Allen key adjustment
- Push-in connection
- Wide range of sizes



Operating and additional information

Operating pressure: 1 to 10 bar
 Operating temperature: -25°C to +100°C
 Sealing device: M5 Nylon washer
 1/8 - 1/2 BSPP Nitrile E.D. seal
 Terminations: 4mm - 12mm push-in connection
 1/8 - 1/2 BSPP + M5 Female thread DIN 3852 long
 Maximum connecting torque: M5= 0,5Nm ; 1/8=9Nm ; 1/4=15Nm ; 3/8=22Nm ; 1/2=42Nm
 Body material: Brass blackepoxy coated
 Lock nut: Brass

PTF4/8PB - Flow regulator with push-in connection

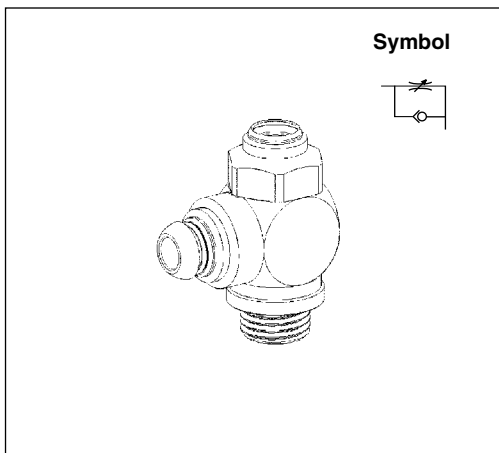

Thread	Port thread	Number of turns	Qmax input at 6 bar, l/min*	Weight kg	Order code
M5x0,8	4	19	33,4	0,014	PTF8PB4M5**
G1/8	4	18	105	0,035	PTF4PB4-1/8
M5x0,8	6	19	36	0,019	PTF8PB6M5**
G1/8	6	18	160	0,037	PTF4PB6-1/8
G1/4	6	12,5	360	0,065	PTF4PB6-1/4
G1/4	6	17	440	0,142	PTF4PB6-3/8
G1/8	8	18	160	0,043	PTF4PB8-1/8
G1/4	8	12,5	355	0,070	PTF4PB8-1/4
G3/8	8	17	720	0,146	PTF4PB8-3/8
G1/4	10	12,5	380	0,067	PTF4PB10-1/4
G3/8	10	17	835	0,131	PTF4PB10-3/8
G1/2	10	21	974	0,231	PTF4PB10-1/2
G3/8	12	17	805	0,200	PTF4PB12-3/8
G1/2	12	21	1284	0,232	PTF4PB12-1/2

* Screw closed

** These fittings are supplied with Nylon seal

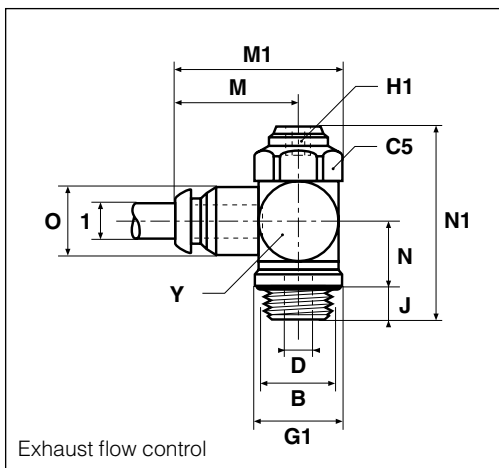

Order code	C5	D	G1	H1	J	M	M1	N	N1	O	Y
PTF8PB4M5**	8	1,65	10,0	1,5	4	19,5	24,5	6,3	22,0	10	10
PTF4PB4-1/8	14	3,00	14,4	2,0	6	22,0	30,1	10,7	34,5	10	14
PTF8PB6M5**	8	1,65	10,0	1,5	4	20,5	26,5	7,3	24,5	12	12
PTF4PB6-1/8	14	3,20	14,4	2,0	6	23,5	31,6	10,7	34,5	12	14
PTF4PB6-1/4	17	5,20	18,4	4,0	7	25,0	34,9	13,8	41,0	12	17
PTF4PB6-3/8	22	5,50	21,6	4,0	7	28,0	40,7	17,3	51,0	12	22
PTF4PB8-1/8	14	3,20	14,4	2,0	6	25,0	33,1	10,7	34,5	14	14
PTF4PB8-1/4	17	5,20	18,4	4,0	7	28,5	38,3	13,8	41,0	14	17
PTF4PB8-3/8	22	6,00	21,6	4,0	7	29,5	42,2	17,3	51,0	14	22
PTF4PB10-1/4	17	5,20	18,4	4,0	7	31,5	41,3	13,8	41,0	17	17
PTF4PB10-3/8	22	6,00	21,6	4,0	7	34,0	46,7	17,3	51,0	17	22
PTF4PB10-1/2	27	8,00	26,5	4,0	9	36,5	52,1	20,1	61,0	17	27
PTF4PB12-3/8	22	6,00	21,6	4,0	7	34,0	46,7	17,3	51,0	20	22
PTF4PB12-1/2	27	8,50	26,5	4,0	9	36,5	52,1	20,1	61,0	20	27

Exhaust flow control

- For direct mounting on to cylinder
- Allen key adjustment
- Push-in connection
- Wide range of sizes



Operating and additional information

Operating pressure:	1 to 10 bar
Operating temperature:	-25°C to +70°C
Bolt material:	Brass black epoxy coated
Swivel elbow material:	High resistance polyamide
Bolt material:	Brass
Bolt threads:	M5 - 1/8 BSPP - 1/4 BSPP - 3/8 BSPP
Sealing device:	Nylon washer 1/8 - 3/8 BSPP Nitrile E.D. seal
Terminations:	4mm - 8mm push-in connection
Maximum connecting torque:	M5= 0,5Nm ; 1/8=9Nm ; 1/4=15Nm ; 3/8=22Nm ; 1/2=42Nm
Adjustment screw:	Brass

Flow adjustment

Flow control is adjusted with an Allen key.
The large number of turns from fully closed to fully open allows for precise flow control.

PTF4/8E6PB - Flow regulator with push-in connection

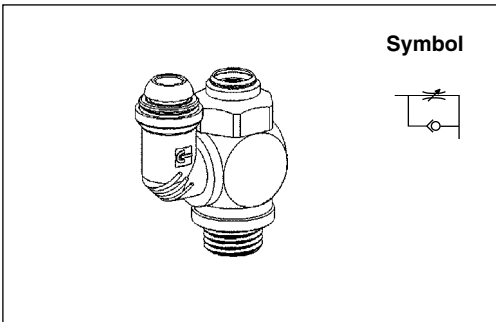

Thread	Port thread	Number of turns	Qmax input at 6 bar, l/min*	Weight kg	Order code
M5x0,8	4	19	35	0,016	PTF8E6PB4M5**
G1/8	4	18	68	0,037	PTF4E6PB4-1/8
M5x0,8	6	18	37	0,020	PTF8E6PB6M5**
G1/8	6	18	175	0,038	PTF4E6PB6-1/8
G1/4	6	12,5	215	0,070	PTF4E6PB6-1/4
G3/8	6	17	250	0,132	PTF4E6PB6-3/8
G1/8	8	18	155	0,040	PTF4E6PB8-1/8
G1/4	8	12,5	343	0,073	PTF4E6PB8-1/4
G3/8	8	17	505	0,136	PTF4E6PB8-3/8

* Screw closed
** These fittings are supplied with Nylon seal

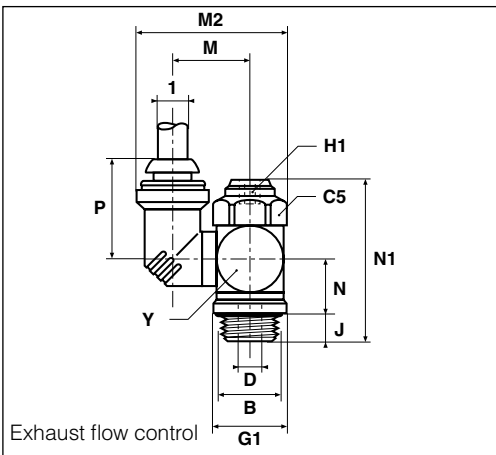

Order code	C5	D	G1	H1	J	M	M2	N	N1	P	Y
PTF8E6PB4M5**	8	1,65	10,0	1,5	4	11,7	18,4	6,2	22,5	20,5	10
PTF4E6PB4-1/8	14	3,00	14,4	2,0	6	14,3	30,0	10,7	34,5	20,5	14
PTF8E6PB6M5**	8	1,65	10,0	1,5	4	12,7	20,4	7,2	24,5	23,0	12
PTF4E6PB6-1/8	14	3,20	14,4	2,0	6	15,3	31,0	10,7	34,5	23,0	14
PTF4E6PB6-1/4	17	5,20	18,4	4,0	7	17,3	35,0	13,8	41,0	23,0	17
PTF4E6PB6-3/8	22	5,50	21,6	4,0	7	19,8	40,0	17,3	51,0	23,0	22
PTF4E6PB8-1/8	14	3,20	14,4	2,0	6	16,8	33,5	10,7	34,5	25,0	14
PTF4E6PB8-1/4	17	5,20	18,4	4,0	7	18,3	37,0	13,8	41,0	25,0	17
PTF4E6PB8-3/8	22	6,00	21,6	4,0	7	20,8	42,0	17,3	51,0	25,0	22

- For inline or surface mounting
- Manual adjustment by knob with lock nut
- Instant push-in fitting
- High flow
- Wide range of sizes



Operating and additional information

Operating pressure:	1 to 10 bar
Permissible fluids:	Air or neutral gas 50micron or filtration, lubricated or not
Flow:	See table below
Operating temperature:	-15°C to +70°C
Storage temperature:	-20°C to +70°C
Vibration resistance:	Conforming to section 19-2 of Bureau Veritas regulations
Body material:	Thermo plastic
Adjustment mode:	Knurled knob
Adjustment locking:	Hexagonal lock nut

Main data for Speed Controls, PWR-L Series

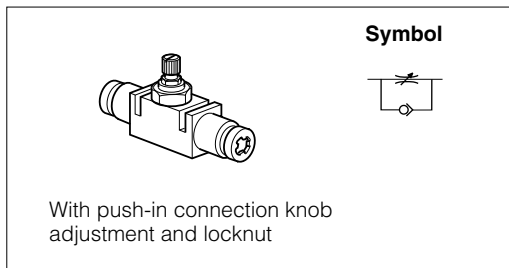

Push-in connection	Adjustment angle	Qmax input at 6 bar, l/min*	Weight kg	Order code
4	13	200	0,02	PWR-L1444
6	12	400	0,04	PWR-L1466
8	15	720	0,06	PWR-L1488
10	18	1360	0,13	PWR-L1499
12	20	1950	0,15	PWR-L1411

* Screw closed

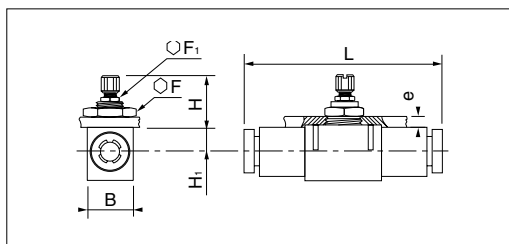

Order code	B	F	F1	e	H+	H-	H1	L	Q
PWR-L1444	12,0	14	*	6	25,5	21,5	6,5	39,0	10,5
PWR-L1466	17,0	19	*	7	32,5	27,5	7,5	54,0	17,0
PWR-L1488	18,5	24	11	7	34,5	28,5	9,0	60,5	19,0
PWR-L1499	24,0	30	14	7	38,5	29,5	11,5	76,0	25,0
PWR-L1411	28,0	32	14	8	42,0	32,0	12,5	86,0	28,0

- Micrometer type adjustment
- Fine control
- Integral mounting hole
- Non-return and needle valves



Operating and additional information

Operating pressure: 0 to 17 bar
 Flow: See curve below
 Operating temperature: -40°C to +80°C
 Body material: Brass
 Control knob: Aluminium
 Adjustment mode: Knurled knob

Flow Control with By-pass

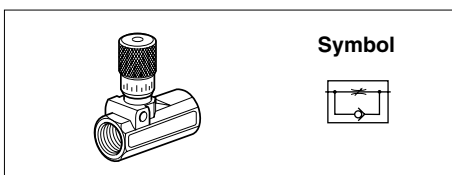

Thread	Number of turns	Qmax input at 6 bar, l/min	Weight kg	Order code
G1/8	5	300	0,076	337A
G1/4	6	780	0,134	337B

Flow Control with By-directional Control

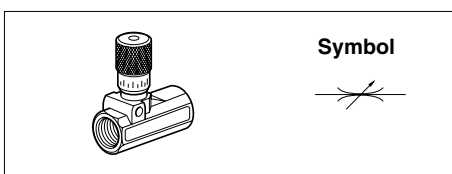

Thread	Number of turns	Qmax input at 6 bar, l/min	Weight kg	Order code
G1/8	5	300	0,078	338A
G1/4	6	780	0,132	338B

Micrometer Flow Control Valves - Dimensions

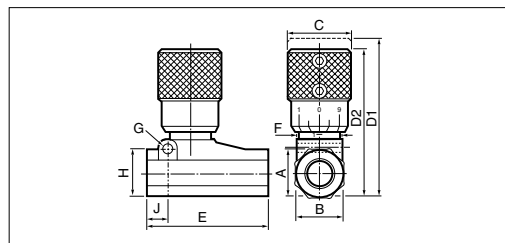
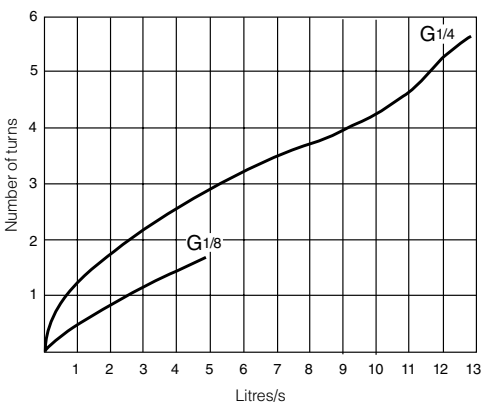

Order code	Port size	A	B	C	D1 open	D2 closed	E	F	G	H	J
337A	G1/8	14,5	14,5	19	51	46	40	12	-	-	-
337B	G1/4	17,5	18,0	19	58	51	50	12	4,8	19	10
338A	G1/8	14,5	14,5	19	51	46	40	12	-	-	-
338B	G1/4	17,5	18,0	19	58	51	50	12	4,8	19	10

- Screw driver or hand adjustment
- Rugged brass bodies
- Panel mounted versions
- High flow rate
- High flow by-pass
- Wide range of sizes



Operating and additional information

Operating pressure:	0 to 28 bar for air - 0 to 55 bar oil or water
Operating temperature:	-10°C to +80°C
Body material:	Brass
Control knob:	Brass
Adjustment mode:	Knurled knob or screw driver adjustment

Standard Type

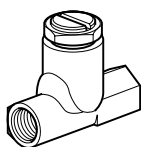

Symbol



Thread	Number of turns	Qmax input at 6 bar, l/min*	Weight kg	Order code
G1/8	6	1320	0,114	B3250X
G1/4	5	2880	0,224	B3250AB
G3/8	5	6300	0,378	B3250BB
G1/2	5	7680	0,792	B3250CB
G3/4	4,5	10680	1,300	B3250DB

Panel Mounting Type

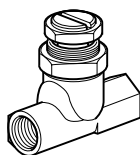

Symbol



Thread	Number of turns	Qmax input at 6 bar, l/min*	Weight kg	Order code
G1/8	6	1320	0,120	B3250XP
G1/4	5	2880	0,226	B3250ABP

Panel Mounted Hand Adjustment Type

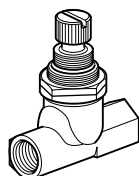

Symbol



Thread	Number of turns	Qmax input at 6 bar, l/min*	Weight kg	Order code
G1/8	6	1320	0,128	B3250HX
G1/4	5	2880	0,238	B3250HA

* Screw closed

Dimensions, Flow Control Valves, B3250 Series

Flow Control Valves, Panel Mounted Hand Adjustment Type

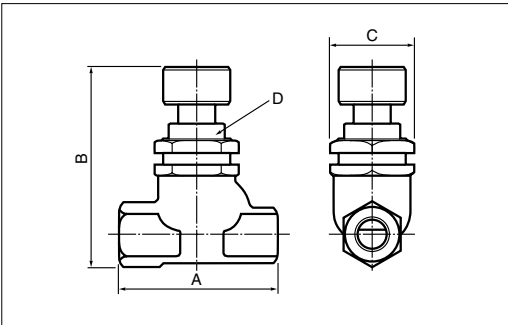

Order code	Port size	A	B	C	D
B3250HX	G1/8	44	57	21	20
B3250HA	G1/4	57	70	32	25

Flow Control Valves, Standard Type

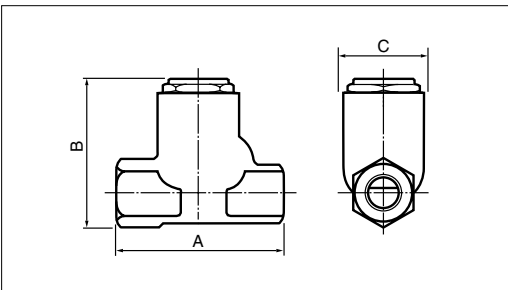

Order code	Port size	A	B	C
B3250X	G1/8	44	40	21
B3250AB	G1/4	57	51	28
B3250BB	G3/8	68	64	35
B3250CB	G1/2	79	78	41
B3250DB	G3/4	90	92	51

Flow Control Valves, Panel Mounted Type

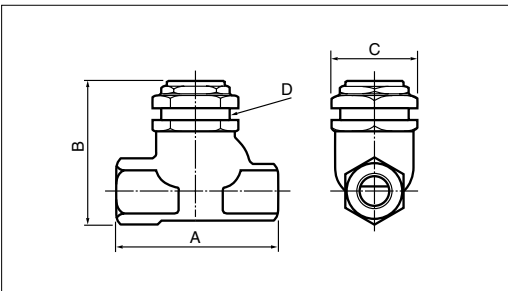

Order code	Port size	A	B	C	D
B3250XP	G1/8	44	40	21	20
B3250ABP	G1/4	57	51	32	25

- Integral mounting holes
- Screw driver adjustable
- Panel mounting option



Operating information

Working pressure Max 10 bar
 Working temperature -20 °C to +70 °C

Flow Control Valves with By-pass

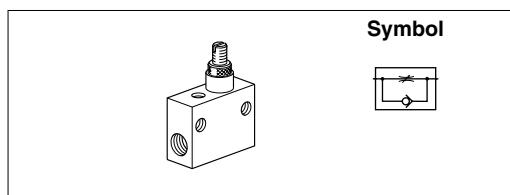

Thread	Number of turns	Qmax input at 6 bar, l/min	Weight kg	Order code
G1/8	13	72	0,03	VQB12-Q-0X-5*
G1/8	13	240	0,03	VQB12-Q-0-5
G1/4	13	1320	0,07	VQB22-Q-0-5
G1/2	13	3600	0,27	VQB42-Q-0-5

Flow Control Valves with By-directional Control

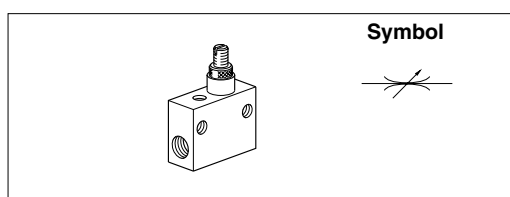

Thread	Number of turns	Qmax input at 6 bar, l/min	Weight kg	Order code
G1/8	13	72	0,03	VQB12-0X-5*
G1/8	13	240	0,03	VQB12-0-5
G1/4	13	1320	0,07	VQB22-0-5
G1/2	13	3600	0,26	VQB42-0-5

* Extra fine adjustment

Knob and nut for Panel Mounting

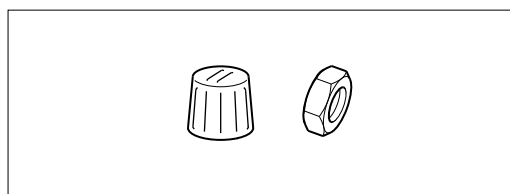

To Suit	Weight kg	Order code
VQB12	0,008	9128177212
VQB22	0,014	9128177222
VQB42	0,037	9128177242

Dimensions, Flow Control Valves, VQB Series

Flow Control Valves - Dimensions

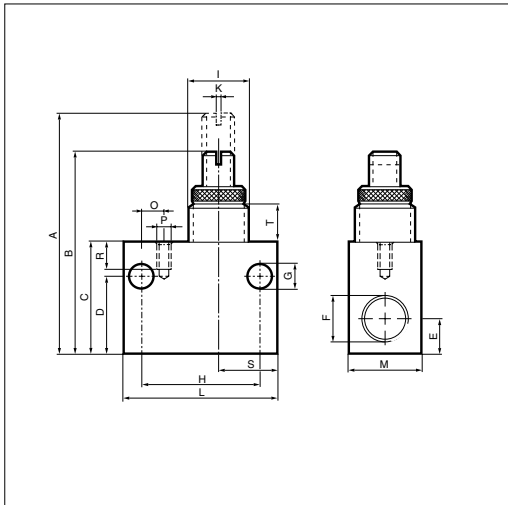

Order code	A	B	C	D	E	F	G	H	I
VQB12-(Q)-OX-5	49	42	22	15	6,5	G1/8	5,8	24	M12x1
VQB12-(Q)-O-5	49	42	22	15	6,5	G1/8	5,8	24	M12x1
VQB22-(Q)-O-5	64	53	30	21	8,5	G1/4	7,0	32	M16x1
VQB42-(Q)-O-5	99	85	50	36	16,5	G1/2	7,0	50	M24x1,5

Order code	K	L	M	O	P	R	S	T
VQB12-(Q)-OX-5	1,2	32	15	-	-	-	13,5	8,8
VQB12-(Q)-O-5	1,2	32	15	-	-	-	13,5	8,8
VQB22-(Q)-O-5	1,2	42	20	6,0	M4	7	16,0	10,0
VQB42-(Q)-O-5	1,8	62	30	19,5	M4	7	20,5	15,2

- For direct cylinder mounting
- Blocker only or multifunction options
- Threaded or push-in ports
- Blocker/Flow Regulator device adjustable with manual barrel
- Wide range of sizes



Operating information

Operating pressure:	1 to 10 bar
Permissible fluids:	Air or neutral gas 50micron or filtration, lubricated or not
Flow:	See table opposite
Operating temperature:	-15°C to +60°C
Storage temperature:	-40°C to +70°C
No. of operations with dry air at 6 bar 20°C 1 Hz:	10 million
Maximum operating frequency:	10Hz
Vibration resistance:	According to IEC 68 - 2 - 6
Maximum connecting torque:	1/8 = 8Nm ; 1/4 = 12Nm; 3/8 = 30Nm; 1/2 = 35Nm
Body material (Blocker):	Zinc alloy
Body material (Blocker/Flow Regulator):	Thermo plastic
Connection thread:	Brass
Adjustment mode (Blocker/Flow Regulator):	Rotating barrel
Adjustment locking (Blocker/Flow Regulator):	Knurled lock nut
Internal seal at 6 bar:	≤ 0,6 l/h ANR

With Push-in Connection

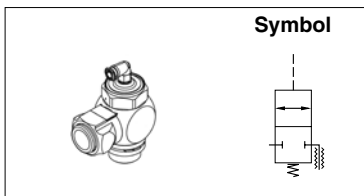

Connection for pilot port	Thread	Connection for tube ,Ømm	Qmax input at 6 bar, l/min	Weight kg	Order code
Push-in Ø4mm	G1/8	6	500	0,15	PWB-A1468
	G1/4	6	650	0,15	PWB-A1469
	G1/4	8	650	0,15	PWB-A1489
	G3/8	8	1600	0,18	PWB-A1483
	G3/8	10	1750	0,18	PWB-A1493
	G1/2	12	2050	0,50	PWB-A1412

With Threaded Connection

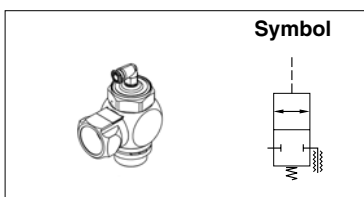

Connection for pilot port	Thread	Connection for tube ,Ømm	Qmax input at 6 bar, l/min*	Weight kg	Order code
Push-in Ø4mm	G1/8	G1/4	500	0,18	PWB-A1898
	G1/4	G1/4	650	0,18	PWB-A1899
M5*	G3/8	G3/8	1750	0,19	PWB-A1833
	G1/2	G1/2	2050	0,48	PWB-A1822

* Available with Ø4mm push-in connection, add 4 to the end of the Order code; example: **PWB-A18994**

With Push-in Connection, Barrel Adjustment and Locknut

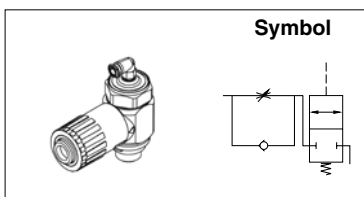

Connection for pilot port	Thread	Connection for tube ,Ømm	Qmax input at 6 bar, l/min	Weight kg	Order code
Ø4mm	G1/8	4	330	0,13	PWR-HB1448
	G1/8	6	500	0,13	PWR-HB1468
	G1/4	6	500	0,13	PWR-HB1469
	G1/4	8	600	0,13	PWR-HB1489
	G3/8	8	1200	0,18	PWR-HB1483
	G3/8	10	1300	0,18	PWR-HB1493
	G1/2	10	1400	0,13	PWR-HB1492

Blockers	Pilot				Depilot			
	operating pressure				operating pressure			
	2bar	4bar	6bar	8bar	2bar	4bar	6bar	8bar
PWB-A1898	3,1	3,5	4,0	4,5	0,8	1,0	1,2	1,4
PWB-A1899	3,1	3,5	4,0	4,5	0,8	1,0	1,2	1,4
PWB-A1833	2,5	2,8	2,9	3,4	1,1	1,3	1,6	1,9
PWB-A1822	2,5	2,8	2,9	3,4	1,1	1,3	1,6	1,9

Combined speed controllers & blockers	Pilot				Depilot			
	operating pressure				operating pressure			
	2bar	4bar	6bar	8bar	2bar	4bar	6bar	8bar
PWR-HB1448	3,1	3,5	4,0	4,5	0,8	1,0	1,2	1,4
PWR-HB1468	3,1	3,5	4,0	4,5	0,8	1,0	1,2	1,4
PWR-HB1469	3,1	3,5	4,0	4,5	0,8	1,0	1,2	1,4
PWR-HB1489	3,1	3,5	4,0	4,5	0,8	1,0	1,2	1,4
PWR-HB1483	2,5	2,8	2,9	3,4	1,1	1,3	1,6	1,9
PWR-HB1493	2,5	2,8	2,9	3,4	1,1	1,3	1,6	1,9

Blocker with push-in connection - dimensions

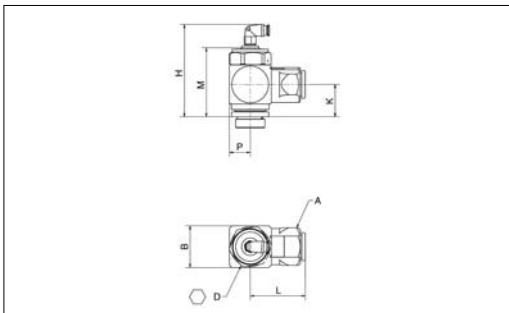

Order code	A	B	D	H	K	L	P	M
PWB-A1468	∅ 22	21	21	59,0	16,5	39	11	43
PWB-A1469	∅ 22	21	21	59,0	16,5	39	11	43
PWB-A1489	∅ 22	21	21	59,0	16,5	39	11	43
PWB-A1483	□ 27	30	27	66,5	22,5	39	15	52
PWB-A1493	□ 27	30	27	66,5	22,5	39	15	52
PWB-A1412	□ 27	30	27	66,5	22,5	39	15	52

Blocker with threaded connection - dimensions

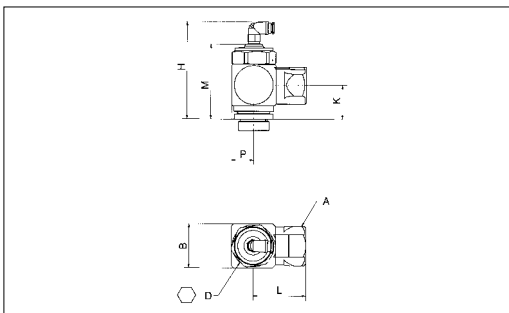

Order code	A	B	D	H	K	L	C	P	M
PWB-A1898	∅ 22	21	21	59,0	16,5	43,5	∅ 24	11	43
PWB-A1899	∅ 22	21	21	59,0	16,5	43,5	∅ 24	11	43
PWB-A1833	□ 27	30	27	66,5	22,5	36,0	□ 27	15	52
PWB-A1822	□ 27	30	27	66,5	22,5	36,0	□ 27	15	52

Blocker/Flow regulator - dimensions

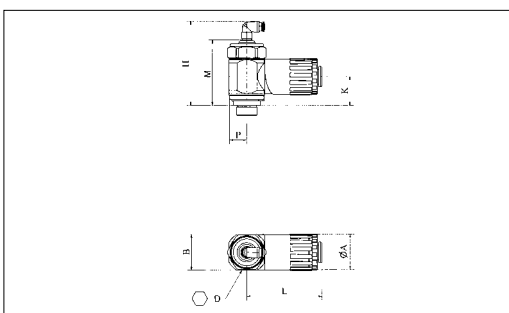

Order code	∅A	B	D	H	K	L	P
PWR-HB1448	22,5	21	21	59	16,5	47,0	12,5
PWR-HB1468	22,5	21	21	59	16,5	47,0	12,5
PWR-HB1469	22,5	21	21	59	16,5	47,0	12,5
PWR-HB1489	22,5	21	21	59	16,5	47,0	12,5
PWR-HB1483	29,0	30	27	64,5	22,5	60,0	15,0
PWR-HB1493	29,0	30	27	64,5	22,5	60,0	15,0
PWR-HB1492	29,0	30	27	64,5	22,5	60,0	15,0

- Increases piston speeds, super sensitive diaphragm
- Extremely low operating differential
- Virtually stiction free
- May be used as differential shuttle valve
- High temperature option



Operating information

Operating pressure: 0,2 to 10 bar
 Operating temperature (Standard): -10°C to +80°C
 Operating temperature (High): -10°C to +180°C
 Body material: Aluminium
 Diaphragm material (Standard): Nitrile
 Diaphragm material (High): Viton

Standard version

Port Size	Cv Rating	Weight kg	Order Code
G1/4	2,3	0,20	P4Q-BA12
G3/8	3,6	0,18	P4Q-BA13
G1/2	6,6	0,50	P4Q-CA14
G3/4	7,3	0,44	P4Q-CA16

High temperature version

Port Size	Cv Rating	Weight kg	Order Code
G1/4	2,3	0,20	P4Q-BV12
G3/8	3,6	0,18	P4Q-BV13
G1/2	6,6	0,50	P4Q-CV14
G3/4	7,3	0,44	P4Q-CV16

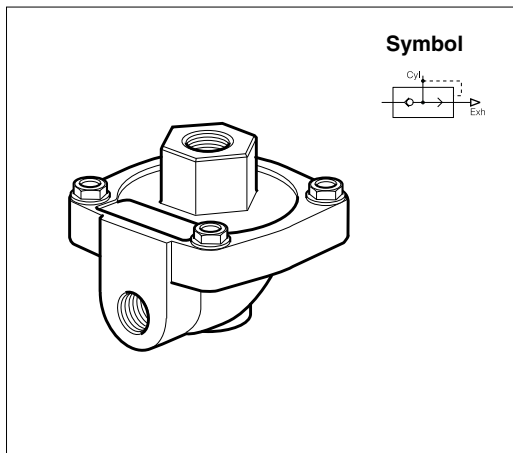

Quick Exhaust Valves - Dimensions

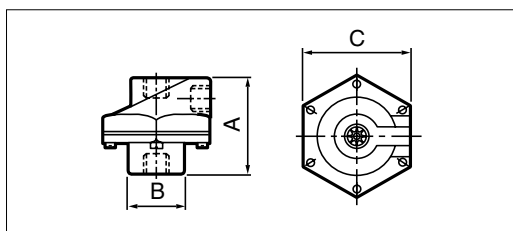

Order code	Port Size	A	B	C
P4Q-B*12	G1/4	52	25	62
P4Q-B*13	G3/8	52	25	62
P4Q-B*14	G1/2	73	38	86
P4Q-B*16	G3/4	73	38	86

Shuttle valves

- Allows two separate signals to be applied to the air pilot
- 0,6 bar differential, Viton seals as standard



Operating information

Operating pressure:	1,3 to 17 bar
Flow:	See table below
Operating temperature:	-10°C to +60°C
Body material M5 and G1/8:	Aluminium
Body material G1/4	Zinc
Shuttle ball material:	Plastic

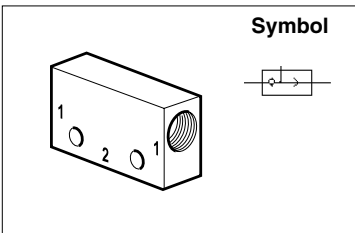

Port Size	Qmax input at 6 bar, l/min	Weight kg	Order Code
M5	36	0,040	M33005
G1/8	509	0,100	B43005B
G1/4	1076	0,172	B53005A

Shuttle Valves - Dimensions

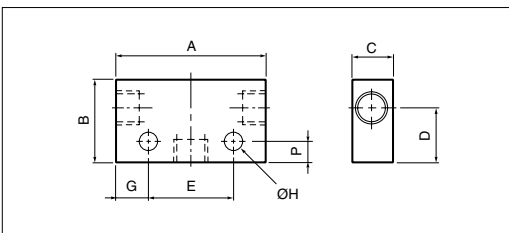

Order code	Port Size	A	B	C	D	E	F	G	H
M33005	M5	27,5	24	15	16,0	15	6	6,3	3,2
M43005B	G1/8	44,0	24	15	16,0	25	6	9,5	4,5
B53005A	G1/4	52,0	30	22	20,5	35	10	8,5	5,5

- Detects stoppage of a cylinder due to a pressure drop in the exhaust chamber
- For direct mounting to cylinders
- Choice of pneumatic, electrical or electronic output
- Wide range of sizes



Operating information

Operating pressure:	0 to 10 bar
Permissible fluids:	Air or neutral gas 50micron or filtration, lubricated or not
Operating temperature:	-15°C to +60°C
Storage temperature:	-40°C to +70°C
No. of operations with dry air at 6 bar 20°C 1 Hz:	10 million
Maximum operating frequency:	10 Hz
Output characteristics:	Pneumatic: Flow at 6 bar 90l/mn Electrical:C/contact 2,5A/250V AC, 5W 48V DC Electronic: PNP N/C or N/O 10 to 30V 75 mA DC
Maximum connecting torque:	M5 = 1Nm; 1/8 = 8Nm; 1/4 = 12Nm; 3/8 = 30Nm; 1/2 = 35Nm
Body material:	Thermo plastic
Connection thread:	Brass

Dimensions and piloting pressures next page

Assembly

All back pressure sensors are a combination of two distinct parts: a banjo socket + a plug-in sensor.

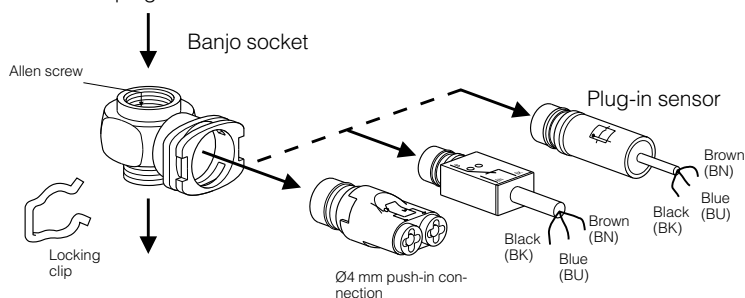

Connection

Output signal connection

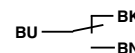

Pneumatic output sensor: Ø4 mm push-in

Electric output sensor

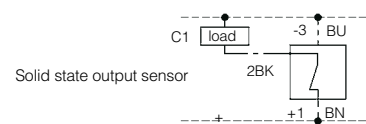

Banjo Sockets

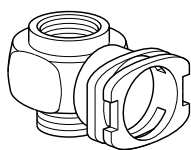

Thread Size for Cylinder Port	Female Thread	Tool Required	Weight Kg	Order code
M5	M5	8mm flat spanner	0,04	PWS-B155
G1/8	G1/8	5mm Allen key	0,04	PWS-B188
G1/4	G1/4	8mm Allen key	0,05	PWS-B199
G3/8	G3/8	10mm Allen key	0,07	PWS-B133
G1/2	G1/2	12mm Allen key	0,11	PWS-B122

Plug-in Sensors

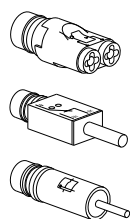

Sensing function	Output function	Output Connection	Output characteristics	Weight kg	Order code
Exhaust back pressure decay	Pneumatic	Push-in Ø4mm	NO valve flow rate at 6 bar 90 l/mn	0,09	PWS-P111
	Electrical ~Ve = 3A	3 wires 0,5mm ² length 2m	CO contact 12 to 230V ~ / 10VA* 12 to 48 VDC/5W*	0,08	PWS-M1012
	Solid state	3 wires 0,1mm ² length 2m	PNP type NC	0,07	PWS-E101
			10/30VDC** 75 mA, NO	0,07	PWS-E111

* Suitable for low currents : 250 V ~ / 4 mA ; 24 VDC / 10 mA ** Including ripple

- Detects stoppage of a cylinder due to a pressure drop in the exhaust chamber
- Single unit design
- For direct mounting to cylinders
- Pneumatic output
- Wide range of sizes



Operating information

Operating pressure:	0 to 10 bar
Permissible fluids:	Air or neutral gas 50micron or filtration, lubricated or not
Operating temperature:	-15°C to +70°C
Storage temperature:	-20°C to +70°C
No. of operations with dry air at 6 bar 20°C 1 Hz:	10 million
Maximum operating frequency:	1 Hz
Output characteristics:	Flow @ 6 bar 90l/m
Maximum connecting torque:	M5 = 1Nm; 1/8 = 8Nm; 1/4 = 12Nm; 3/8 = 30Nm; 1/2 = 35Nm
Body material:	Zinc alloy / Thermo plastic
Connection thread:	Brass

Plug-in & Monoblock back pressure sensors	Pilot	Depilot
	operating pressure	operating pressure
PWS-P111	6bar	6bar
PWS-M1012	4,4	0,4
PWS-E101 & E111	1,5	0,6
PWS-C	1,5	0,6
	1,6 ±0,2	0,3

Back Pressure Sensor for Cylinder Mounting

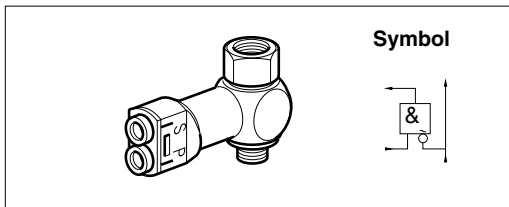

Thread Cylinder Port	Thread Supply Port	Bore Ømm	Weight kg	Order code
M5	M5	2	0,10	PWS-C5145
G1/8	G1/8	5	0,11	PWS-C5148
G1/4	G1/4	7	0,10	PWS-C5149
G3/8	G3/8	10	0,17	PWS-C5143
G1/2	G1/2	14	0,15	PWS-C5142

Back Pressure Sensors - Mono block - Dimensions

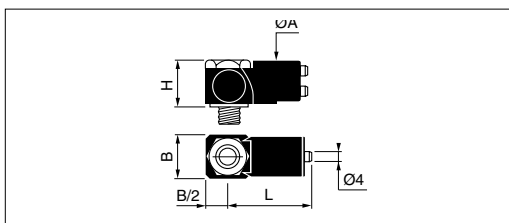

Order code	ØA	B	H	L
PWS-CS145	19	11,0	16,0	42
PWS-CS148	22	16,5	29,0	40
PWS-CS149	22	23,5	26,0	43
PWS-CS143	22	23,5	36,5	43
PWS-CS142	22	32,0	29,5	48

Back Pressure Sensors - Modular - Dimensions

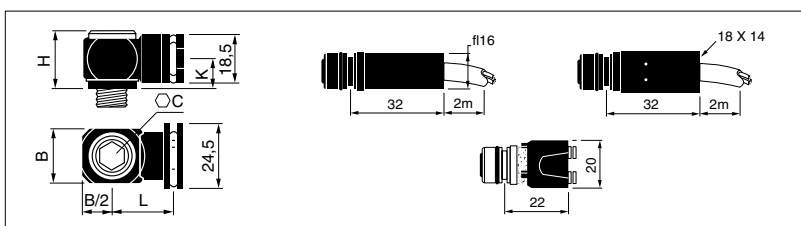

Order code	C	B	H	K	L
PWS-B155	8	11	16,5	10	17
PWS-B188	5	16	20,0	10	20
PWS-B199	8	21	20,0	10	22
PWS-B133	10	28	22,0	12	25
PWS-B122	12	33	26,0	14	26

- Adjusts the actuating force developed by a cylinder
- For direct mounting to power valve
- Threaded or push-in ports
- Adjustment by allen key or knurled knob
- Wide range of sizes



Operating information

Operating pressure:	1 to 8 bar
Permissible fluids:	Air or neutral gas 50micron or filtration, lubricated or not
Flow:	See table below
Operating temperature:	-15°C to +70°C
Storage temperature:	-20°C to +70°C
Maximum connecting torque:	1/8 = 8Nm ; 1/4 = 12Nm; 3/8 = 30Nm
Body material:	Zinc alloy
Connection thread:	Brass
Adjustment mode:	Allen key

With Push-in Connection

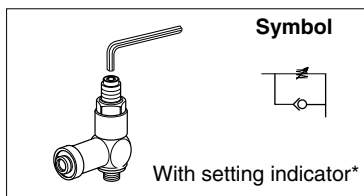

Thread size for cylinder port	Push-in Connection, Ømm	Qmax input at 6 bar, l/min*	Weight kg	Order code
G1/8	6	570	0,30	PWP-B1268
G1/4	6	530	0,30	PWP-B1269
G1/4	8	870	0,30	PWP-B1289
G1/4	10	1400	0,54	PWP-B1299
G3/8	10	1530	0,55	PWP-B1293

* Adjustment is carried out using a 6mm Allen key or a knurled knob.

With Threaded Connection

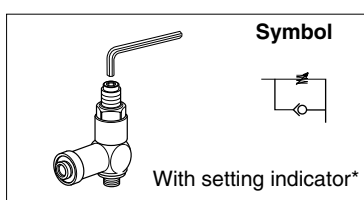

Thread size for cylinder port	Push-in Connection, Ømm	Qmax input at 6 bar, l/min*	Weight kg	Order code
G1/8	G1/8	570	0,34	PWP-B1888
G1/4	G1/4	870	0,34	PWP-B1899
G3/8	G3/8	3200	0,62	PWP-B1833

* Adjustment is carried out using a 6mm Allen key or a knurled knob.

Clip-in knurled adjustment knob for optimisers

Weight kg	Order code
0,03	PWP-Z13

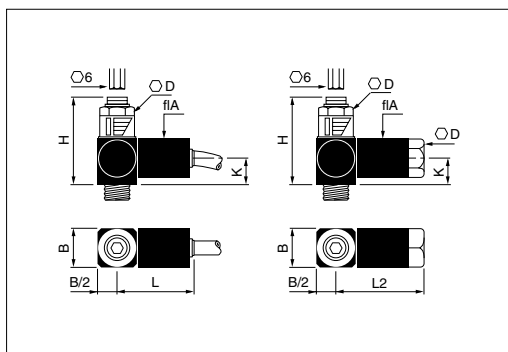

Dimensions

Order code	ØA	B	D	H	K	L	L2
PWP-B1268	22	21	19	58,0	13,5	39	
PWP-B1269	22	21	19	58,0	13,5	39	
PWP-B1289	22	21	19	58,0	13,5	39	
PWP-B1299	27	28	19	65,5	16,5	50	
PWP-B1293	27	28	27	65,5	16,5	50	
PWP-B1888	22	21	19	58,0	13,5		43
PWP-B1899	22	21	19	58,0	13,5		43
PWP-B1833	27	28	27	65,5	16,5		55

- Enables a gradual increase in pressure
- For direct mounting to power valve
- Instant push-in connections
- Adjustment by allen key



Operating information

Operating pressure:	3 to 10 bar
Permissible fluids:	Air or neutral gas 50micron or filtration, lubricated or not
Flow:	See table below
Operating temperature:	-15°C to +70°C
Storage temperature:	-20°C to +70°C
No. of operations with dry air at 6 bar 20°C 1 Hz:	1/4 : 10 million; 3/8 : 5 million
Maximum operating frequency:	1 Hz
Maximum connecting torque:	1/4 = 12Nm; 3/8 = 30Nm
Body material:	Thermo plastic
Connection thread:	Brass
Adjustment mode:	Allen key

With Push-in Connection

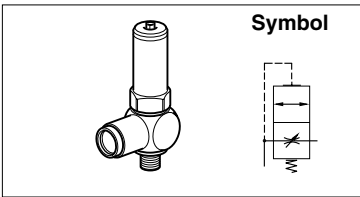

Thread	Push-in Connection, Ømm	Flow rate at 6 bar, l/min	Weight kg	Order code
G1/4	8	1500	0,07	PWD-P2489
G1/4	10	2000	0,12	PWD-P2499
G3/8	10	2000	0,13	PWD-P2493

Dimensions

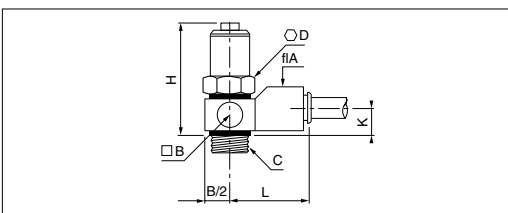

Order code	ØA	B	ØC	D	H maxi	K	L
PWD-P2489	15,0	20	G1/4	17	61	8,5	27,5
PWD-P2499	19,5	25	G1/4	22	62	11,8	41,0
PWD-P2493	19,5	25	G3/8	22	62	11,8	41,0

Operation

A Soft starter provides a progressive increase in pressure, in a section of a pneumatic system. When pressure reaches half the supply pressure, full pressure is applied automatically.

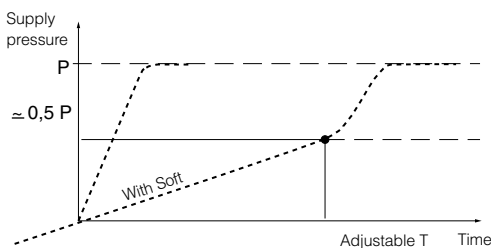

Adjustment

Allen key adjustment of flow rate for slow pressure increase.

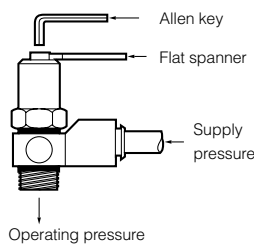

Mounting

These compact devices with push-in tube connection are fitted to the N°1 port of the power valve.

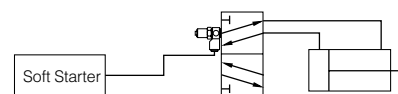

- Rugged brass body design
- Standard or high temperature options
- Low 0,1 bar operating pressure
- Full flow in one direction only
- Compact design



Operating information

Operating pressure: 0,1 to 17 bar
 Flow: Qmax at 6 bar, l/min* 1/8 = 1200L/m; 1/4 - 1350 L/m
 Operating temperature: Standard: -26°C to +85°C
 High: -26°C to +230°C
 Body material: Brass
 Seal material: Standard: Nitrile
 High: Viton

Standard version

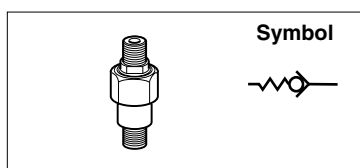

Thread size	Weight kg	Order code
G1/8	0,68	3047X
G1/4	0,72	3047B

High temperature version

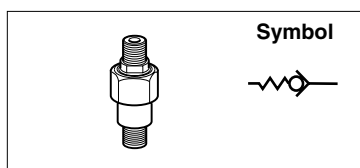

Thread size	Weight kg	Order code
G1/8	0,68	3047XV
G1/4	0,72	3047BV

Dimensions

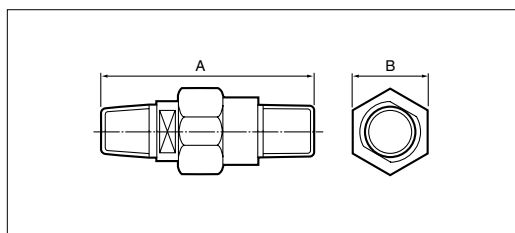

Order code	Port Size	A	B
3047X/XV	G1/8	51	21
3047B/BV	G1/4	49	21

- Aluminium bodies
- Long life
- Low opening pressure
- Full flow in one direction only



Operating information

Operating pressure:	0,1 to 10 bar
Operating temperature:	-20°C to +70°C
Body material:	Anodised aluminium
Seal material:	Nitrile

VB - Aluminium

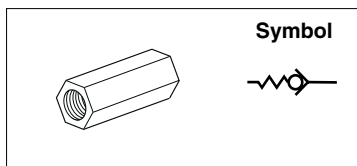

Symbol



Port size	Weight kg	Order code
G1/8	0,01	VB12-Q-NQ-5
G1/4	0,01	VB22-Q-NQ-5
G1/2	0,05	VB42-Q-NQ-5

Dimensions

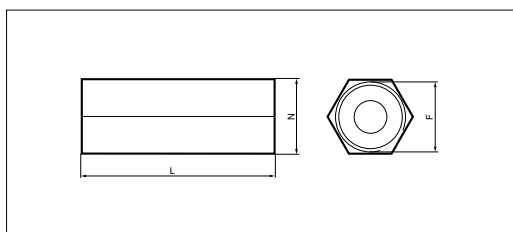

Order code	F	L	N
VB12-Q-NQ-5	G1/8	31	14
VQB22-Q-NQ-5	G1/4	40	17
VB42-Q-NQ-5	G1/2	59	27

- Low 0,1 bar operating pressure
- Full flow in one direction only
- Compact design
- Instant push-in connections



Operating information

Operating pressure:	0,2 to 10 bar
Flow:	See below
Operating temperature:	-15°C to +70°C
Storage temperature:	-20°C to +70°C
Body material:	Thermo plastic

Line Mounted Non-return Valves

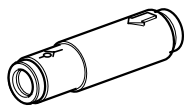

Sold in lots of 10

Symbol



Push-in Connection Ømm	Flow Rate at 6 bar, l/min	Weight kg	Order code
4	200	0,01	PWA-L1444
6	660	0,02	PWA-L1466
8	1600	0,02	PWA-L1488

Dimensions

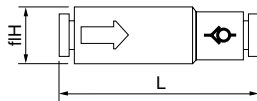

Order code	ØH	L
PWA-L1444	11,0	43,0
PWA-L1466	13,0	49,5
PWA-L1488	13,5	55,0

- For the remote mounting of cylinder control accessories
- Suitable for use with - Flow regulators
 - Blockers
 - Unloaders
 - Combined devices
 - Optimisers
 - Soft start



Operating information

Operating pressure: 0,2 to 10 bar
 Flow: See below
 Operating temperature: -15°C to +70°C
 Storage temperature: -20°C to +70°C
 Body material: Thermo plastic

Terminal Block Subbases for Cylinder Controls*

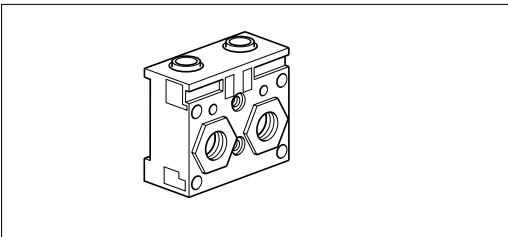

For Mounting Other Cylinder Controls	Push-in Connection Ømm	Bore Ømm	Weight kg	Order code
G1/8	6	4	0,05	PZC-B2268
G1/4	8	6	0,05	PZC-B2289

* For remote mounting of all cylinder controls, when mounting on power valves or cylinders is impractical. The subbase is designed for mounting two components side by side.

Dimensions

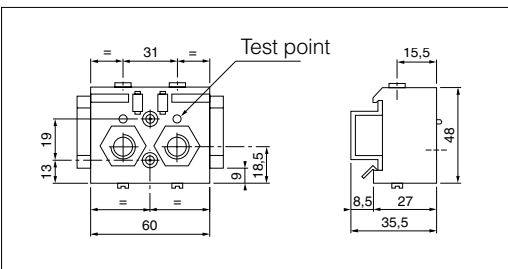

		Page n°
Overview		28 - 29
Exhaust silencers	P6M-PA	30
	PXC, PZC	30
	9090...	31
	9127...	31
	P6M-MA	31
	48021000	31
Restrictors, silencers	9301...	32
	9126...	32
Reclassifiers	P6R	33
Reclassifiers, silencers, metal series repairable and disposable versions	351	34
	M315	35
	ECS	35

Exhaust silencers

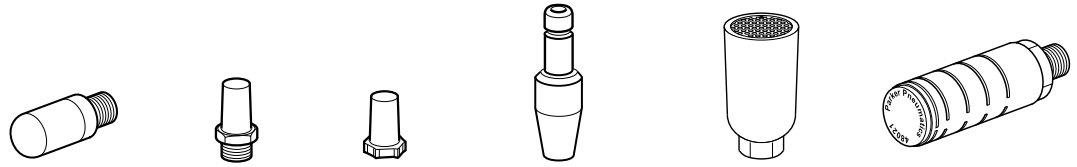

	P6M-PA... Porous polythene	9090... Sintered bronze Male	9721... Sintered bronze Female	PXC PZC all metal	P6M-MA Heavy duty	48021000 Self Cleaning
Adjustable restrictor						
Exhaust silencing	●	●	●	●	●	●
Oil removal						
Disposable	●					
Renewable element						
Cleanable		●			●	
Modular						
Optional manifold						
No of connections	1	1	1	1	1	1
Push-in		●				
Male ports	●	●		●		●
Female ports			●		●	
Size						
G1						
G3/4						
G1/2						
G3/8						
G1/4				8 mm		
G1/8				6 mm		
M5				4 mm		
Refer to page	30	31	31	30	31	31

Exhaust silencers

- All plastic ultra light weight versions
- Sintered metal
- All metal versions for heavy duty applications
- Versions with push-in connections
- High noise level reduction
- Low back pressure generation



Operating and additional information

Plastic	Working temperature: -10°C to +80°C	Efficiency: 92%	
Metal	Working temperature: -10°C to +74°C		Working pressure: up to 17 bar

500 Plastic Series

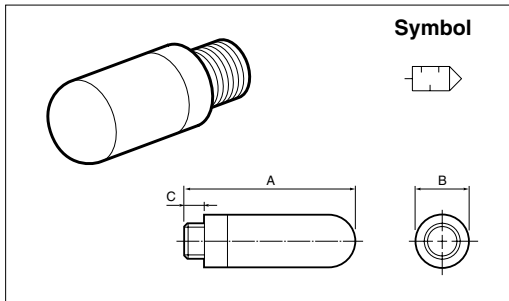

Port thread	A	Ø B	C	Weight g	Order code
M5	23	6,5	4	0,01	P6M-PAC5
G1/8	29	14	6	0,02	P6M-PAB1
G1/4	34	17	6	0,04	P6M-PAB2
G3/8	60	25	9	0,06	P6M-PAB3
G1/2	64	25	11	0,10	P6M-PAB4
G3/4	140	38	14	0,50	P6M-PAB6
G1	160	48	20	0,62	P6M-PAB8

Push-in Series

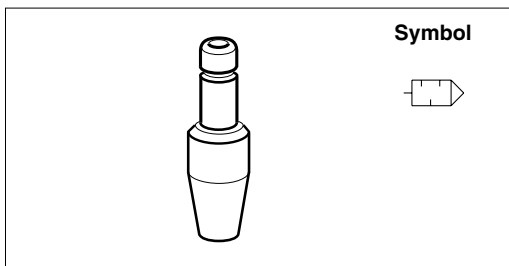

Port mm	Height on Push-in	Weight g	Order code
4	20,0	0,040	PXC-X14
6	35,5	0,025	PZC-S1006
8	34,0	0,030	PZC-S1008

Sintered bronze Series

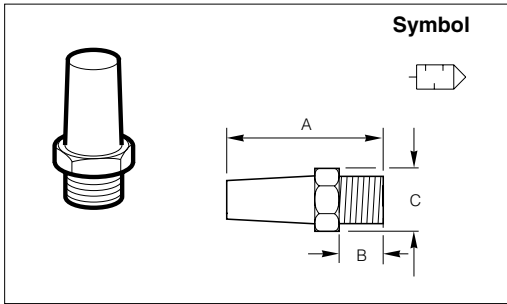

Port thread	A	B	A/F C	Weight g	Order code
M5	23	6,5	4	0,003	9721900005
G1/8	24	10	12	0,009	9090050700
G1/4	32	11	16	0,019	P6M-BAA2
G3/8	43	13	21	0,041	9090050900
G1/2	60	16	24	0,068	9090051000
G3/4	75	10	32	0,126	9090051100
G1	77	12	37	0,188	9090051500

Sintered Bronze Series (female)

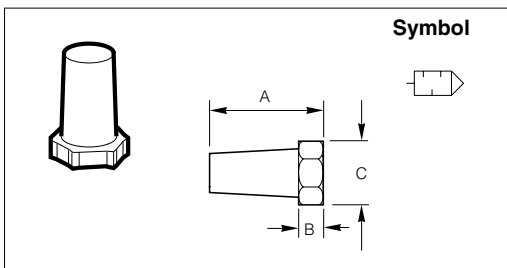

Port mm	A	Ø B	A/F C	Weight g	Order code
G1/8	15	8	13	0,060	9721900404

Heavy Duty Series

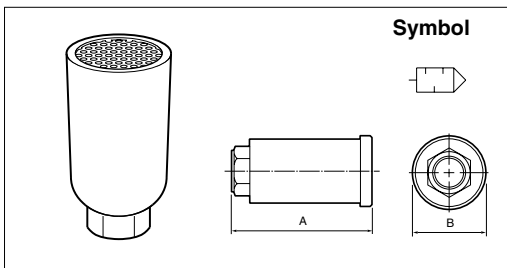

Port Female	A	Ø B	C	Weight g	Order code
G3/8	83	37	-	0,124	P6M-MA13
G1/2	105	51	-	0,362	P6M-MA14
G3/4	143	73	-	0,670	P6M-MA16
G1	143	73	-	0,666	P6M-MA18

Self Cleaning, 48 Series

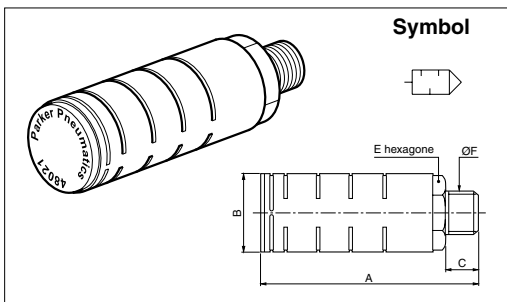

Port thread	A	Ø B	C	A/F E	Weight g	Order code
G1/8	52	16	8	12	0,010	48021000
G1/4	53	22,5	10	17	0,018	48041000
G3/8	78	32	12,7	24	0,042	48061000
G1/2	78	32	14	24	0,042	48081000
G3/4	12	39	16	33	0,082	48121000
G1	120	39	20	33	0,082	48161000

Restrictors - Silencers

- Metal, stainless steel or plastic versions
- Screwdriver adjustment
- Simple control of cylinder speeds
- High noise level reduction



Sintered Metal Series

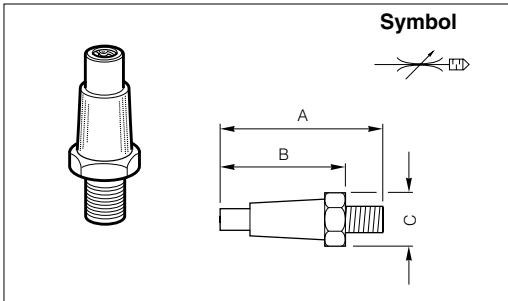

Port thread	A	B	A/F C	Weight g	Order code
M5	16	11	7,6	0,04	33006
R1/8	33	25	13	0,16	43006*
R1/4	49	35	17,5	0,24	T53006
R3/8	68	52	27	0,56	T63006A
G1/2	64	45	27	0,60	B73006

* Sleeve type hand adjusted

Sintered Plastic Series

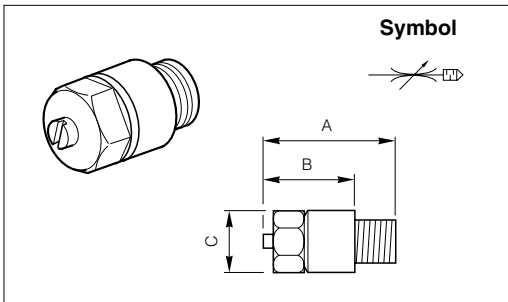

Port thread	A	B	Ø C	Weight g	Order code
G1/8	23	16	7	0,002	9301050901
G1/4	32	23	9	0,004	9301050902
G3/8	40	30	10	0,010	9301050903
G1/2	50	38	12	0,050	9301050904

Sintered Stainless Steel Series

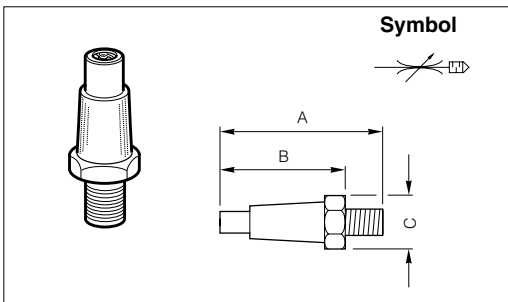

Port thread	A	Ø B	C	Weight g	Order code
G1/8	33	25	13,0	0,040	9126900195
G1/4	49	35	17,5	0,040	9126900196

Reclassifier - Silencers

- Removes oil mist from exhaust airs
- Efficiently silences exhaust air
- Easily replaceable element
- Up to 6 exhaust lines
- Gauge measurement of element efficiency
- Modular design



Operating and additional information

Plastic	Working temperature:	-0°C to +66°C
	Efficiency	>99%
Flow rate	Max	30l/s

The Collectair enables the collection of all the exhaust lines in a system to be routed through a filter element which efficiently removes solid particles and oil vapours. It also silences the exhausting air to approximately 25 dBa. A special gauge shows the level of filter contamination by measuring the over pressure in the element.

Available with either G1/4 , G3/8, G1/2 or G3/4 modular port blocks, the top face of the unit also features 4 rubber grommets for push-in connection of Ø4 mm to Ø10 mm flexible tubing.

Collectair Series, complete units

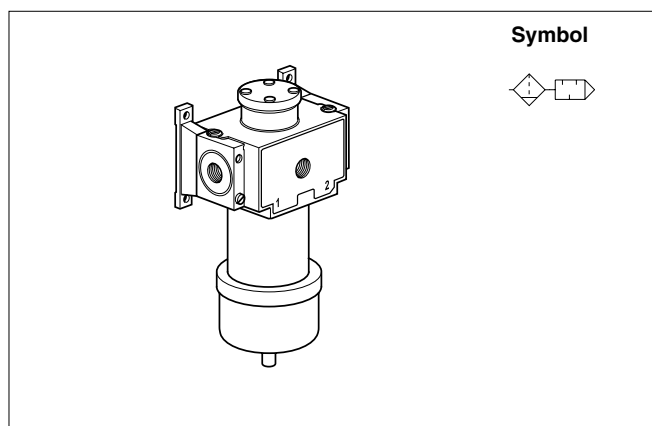

Port thread	A	A1	B	B1
G1/4	102	185	252	202
G3/8	102	185	252	202
G1/2	102	185	252	202
G3/4	102	185	252	202

C	C1	C2	Weight kg	Order code
91	116	117	1,200	P6R-CB12B*
91	116	117	1,200	P6R-CB13B*
91	116	117	1,200	P6R-CB14B*
91	116	117	1,200	P6R-CB16B*

Note: To connect units in series order a complete unit plus one body connector per additional unit.
 Body connector Part No **P3E-KA00CBN**

*Supplied complete with port blocks, wll mounting bracket and pressure gauge to indicate condition

Collectair Series, basic modules

Supplied complete less port blocks, wall brackets and pressure gauge.

Port size	Type of Reclassifier	Weight kg	Order code
None	Collectair	1,076	P6R-CA00N
None	Replacement filter cartridge	0,122	P6R-CK00E

Exhaust silencers

**Reclassifier - Silencers
Metal Series, Repairable and
Disposable versions**

- Removes oil mist from exhaust airs
- Efficiently silences exhaust air
- Improves working conditions



Operating and additional information

Metal repairable version

Working temperature	0 °C to 66 °C max.
Working pressure	Max 7 bar
Efficiency	Better than 99%
Maximum flow rate	G1/2, G3/4 small unit 27,8 l/s G3/4, G1 large unit 50 l/s

Disposable version

Working temperature	0° C to 52 °C max.
Working pressure	Max 7 bar
Efficiency	Better than 99%
Maximum flow rate	See graph

**Disposable version
Flow vs. Noise level**

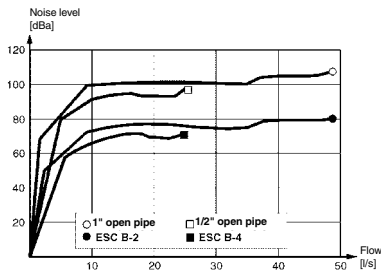

Flow vs. Back pressure

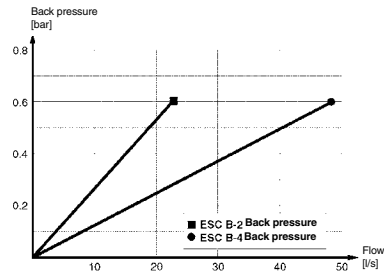

Metal Repairable Series

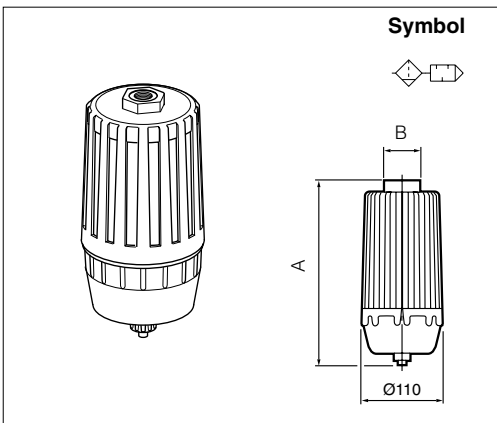

Port thread	Type	A	Ø	A/F B	Weight kg	Order code
G1/2	Small	182	110	50	0,572	3514S
G3/4	Small	182	110	50	0,592	3516S
G3/4	Large	297	110	55	1,100	3516
G1	Large	297	110	55	1,100	3518

Replacement Element	Weight kg	Order code
Small	0,200	3514S-2
Large	0,200	3516-2

Manifold for Metal Repairable version

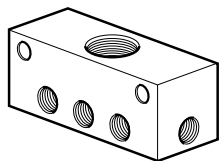

The manifold is available for G3/4 sizes only.
 For other sizes consult Technical Sales Dep't.

No ports	Weight kg	Order code
5	0,270	M3516-5
7	0,432	M3516-7
9	0,574	M3516-9
13	0,870	M3516-13

Wall mounting kit	0,040	3516-W
--------------------------	-------	---------------

Disposable version



Symbol



Port size	Weight kg	Order code
G1/2	0,104	ECSB-2
G3/4	0,134	ECSB-4

www.parker.com

Pneumatic Division Sales Offices

Austria - Wr.Neustadt

Tel: +43 2622 23501
Fax: +43 2622 66212

Belgium - Nivelles

Tel: +32 67 280 900
Fax: +32 67 280 999

**Czech & Slovak
Republics - Klecany**

Tel: +420 284 083 111
Fax: +420 284 083 112

Denmark - Ballerup

Tel: +45 43 560400
Fax: +45 43 733107

Finland - Vantaa

Tel: +358 9 4767 31
Fax: +358 9 4767 3200

France - Contamine

Tel : +33 4 50 25 80 25
Fax : +33 4 50 03 67 37

Germany - Kaarst

Tel: +49 2131 4016-0
Fax: +49 2131 4016-9199

Greece - Athens

Tel: +30 210 933 6450
Fax: +30 210 933 6451

Hungary - Budapest

Tel: +36 1 220 4155
Fax: +36 1 422 1525

Ireland - Dublin

Tel: +353 1 4666370
Fax: +353 1 4666376

Italy - Corsico, Milan

Tel: +39 02 4519 21
Fax: +39 02 4479 340

Netherlands - Oldenzaal

Tel: +31 541 585000
Fax: +31 541 585459

Norway - Langhus

Tel: +47 6491 1000
Fax: +47 6491 1090

Poland - Warsaw

Tel: +48 22 863 49 42
Fax: +48 22 863 49 44

**Portugal - Leça da
Palmeira**

Tel: +351 22 999 7360
Fax: +351 22 996 1527

Romania - Bucharest

Tel: +40 21 252 1382
Fax: +40 21 252 3381

Russia - Moscow

Tel: +7 095 234 0054
Fax: +7 095 234 0528

Slovenia - Novo mesto

Tel: +386 7337 6650
Fax: +386 7337 6651

Spain - Madrid

Tel: +34 91 675 7300
Fax: +34 91 675 7711

Sweden - Spånga

Tel: +46 (0) 8 5979 5000
Fax: +46 (0) 8 5979 5120

Switzerland - Bolligen

Tel: +41 31 917 18 50
Fax: +41 31 917 18 59

Turkey - Istanbul

Tel: +90 212 482 91 06
Fax: +90 212 482 91 10

UK - Warwick

Tel: +44 1926 317 878
Fax: +44 1926 317 855

Ukraine - Kiev

Tel: + 380 44 220 7432
Fax: + 380 44 220 6534



Parker Hannifin plc
Pneumatic Division,
Walkmill Lane, Bridgtown,
Cannock, Staffs. WS11 0LR
United Kingdom

We reserve the right to make
alterations without prior notification.