



aerospace  
climate control  
electromechanical  
filtration  
fluid & gas handling  
hydraulics  
**pneumatics**  
process control  
sealing & shielding



# Rodless Pneumatic Cylinders Magnetically Coupled

Series P1Z

PDE2522TCUK August 2015



ENGINEERING YOUR SUCCESS.



### Important

Before attempting any external or internal work on the cylinder or any connected components, make sure the cylinder is vented and disconnect the air supply in order to ensure isolation of the air supply.



### Note

All technical data in this catalogue are typical data only.  
Air quality is essential for maximum cylinder service life (see ISO 8573).



### WARNING

**FAILURE OR IMPROPER SELECTION OR IMPROPER USE OF THE PRODUCTS AND/OR SYSTEMS DESCRIBED HEREIN OR RELATED ITEMS CAN CAUSE DEATH, PERSONAL INJURY AND PROPERTY DAMAGE.**

This document and other information from Parker Hannifin Corporation, its subsidiaries and authorized distributors provide product and/or system options for further investigation by users having technical expertise. It is important that you analyze all aspects of your application and review the information concerning the product or system in the current product catalog. Due to the variety of operating conditions and applications for these products or systems, the user, through its own analysis and testing, is solely responsible for making the final selection of the products and systems and assuring that all performance, safety and warning requirements of the application are met. The products described herein, including without limitation, product features, specifications, designs, availability and pricing, are subject to change by Parker Hannifin Corporation and its subsidiaries at any time without notice.

### SALE CONDITIONS

The items described in this document are available for sale by Parker Hannifin Corporation, its subsidiaries or its authorized distributors. Any sale contract entered into by Parker will be governed by the provisions stated in Parker's standard terms and conditions of sale (copy available upon request).

<b>Contents</b>	<b>Page</b>
<b>Overview</b> .....	4
<b>Basic Version</b> .....	5
Features .....	5
Technical data .....	6
Materials .....	6
Loads, forces and moments .....	7
Cushioning diagram .....	8
Installation tips for use with external guide .....	8
Dimensions - Basic version .....	9
Dimensions - Flange mounting .....	10
Dimensions - Foot mounting .....	10
Order instructions .....	11
<b>Guided Version</b> .....	12
Features .....	12
Overview .....	13
Technical data .....	14
Materials .....	14
Loads, forces and moments .....	15
Permissible axial load, vertical mounting .....	16
Dimensions - Guided version .....	17
Dimensions - Elastomeric bumpers .....	18
Cushioning diagram for elastomeric bumpers .....	18
Dimensions - Hydraulic shock absorbers .....	19
Dimensions - Al-profile rail for magnetic switches .....	19
Order instructions .....	20
Reed switch and electronic sensors .....	21
<b>Spare parts</b> .....	23

# P1Z Rodless Pneumatic Cylinders Magnetically Coupled

## Overview

### Basic Version



### Hexagonal nuts

(included in scope of delivery)



### Flange mounting

Option



### Foot mounting

Option



### Guided Version



### Air connection on both sides

Standard



### Air connection at one end

Option



### With elastomeric bumpers

Standard



### With hydraulic shock absorbers

Option



### Profile rail for magnetic switches

Option



### Profile rail with magnetic switches

Option



## P1Z Rodless Pneumatic Cylinders Magnetically Coupled

### P1Z Series - Basic Version

Ø 16-40 mm

The P1Z is a rodless pneumatic cylinder. The piston and the carriage are equipped with ring magnets. The motion is transmitted via the magnetic force locking between the piston and the carriage.

#### Features:

- Double acting
- Magnetically coupled without mechanical connection
- Mechanical protection in case of occasional overload due to magnetic uncoupling
- Piston chamber and carriage are pressure tight
- Pressure tight and leak free system
- Dirt and dust cannot enter
- With adjustable pneumatic end cushioning on both sides
- Carriage is free to rotate 360° around the cylinder axis
- Various mounting arrangements

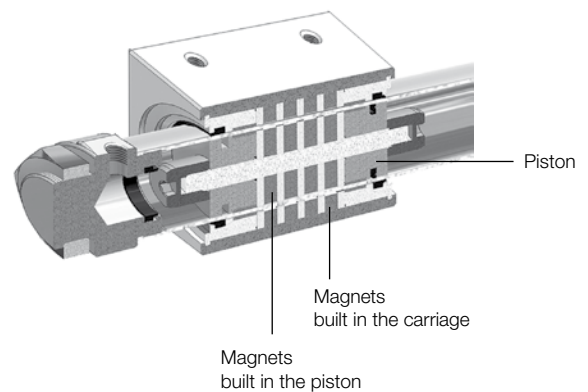
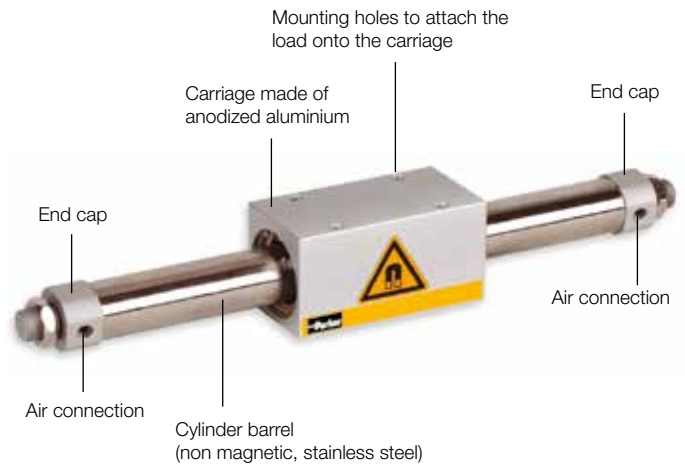

# P1Z Rodless Pneumatic Cylinders Magnetically Coupled

## Mounting and Technical Data Basic Version

- The loads can be fitted onto the carriage by 4 tapped holes.
- The cylinder is mounted at the end caps with hexagonal nuts, flange or foot mountings.



With 2 hexagonal nuts to fix the cylinder (included in scope of delivery)



Flange mounting (pair) option



Foot mounting (pair) option

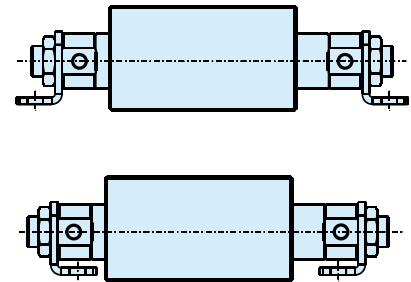
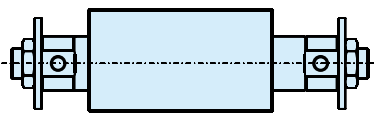

### Technical Data

Piston diameter Ø [mm]	16	20	25	32	40
Max. stroke length [mm]	1000	1500	2000	2000	2000
Stroke tolerance [mm] up to 1000 mm	0/+1.5				
Stroke tolerance [mm] > 1000 mm	0/+2				
Temperature range [°C]	0 to 60				
Operating medium	Filtered compressed air, dry, lubricated or unlubricated * (other media on request)				
Air supply port size	M5	G1/8	G1/8	G1/8	G1/4
Max. magnetic coupling force [N]	157	236	383	703	942
Velocity range [m/s]	0.1 to 1.3				
Min. operating pressure [bar]	1.8				
Max. operating pressure [bar]	6.5	7			
Cushion length [mm]	9	15	15	12	19
Weight [kg]					
at 0 mm stroke	0.28	0.46	0.83	1.35	2.01
per 100 mm stroke	0.043	0.082	0.088	0.14	0.16

### Materials

Cylinder barrel	Stainless steel
Carriage	Anodised aluminium
End cap	Anodised aluminium
Seals	NBR

\* if external lubrication is added, this must always be continued.

# P1Z Rodless Pneumatic Cylinders Magnetically Coupled

## Loads, forces and moments Basic Version

If the operating conditions are outside of the permissible values, either the P1Z guided version or the P1Z in combination with an external guide should be used!

### Forces [N]

Piston [mm]	16	20	25	32	40
Theoretical force at 6 bar [N]	120	188	295	483	754
Max. magnetic coupling force [N]	157	236	383	703	942

### Permissible lateral force, depending on the stroke length

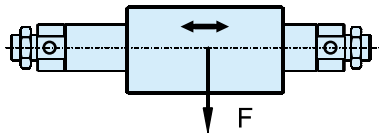

Ø [mm]	Permissible lateral force F [N]
16	30.0
20	50.0
25	70.0
32	100.0
40	165.0

The values are based on velocities  $v \leq 0.4 \text{ m/s}$

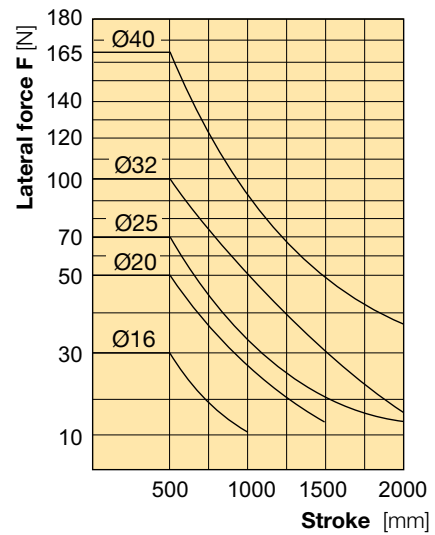

### Permissible axial load, horizontal mounting

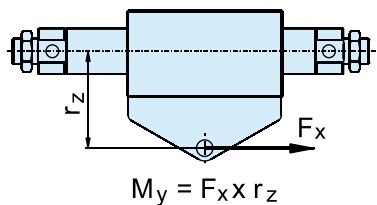

Ø [mm]	Max. Moment My [Nm]
16	1.2
20	2.5
25	3.8
32	8.5
40	13.0

### Permissible axial load, vertical mounting

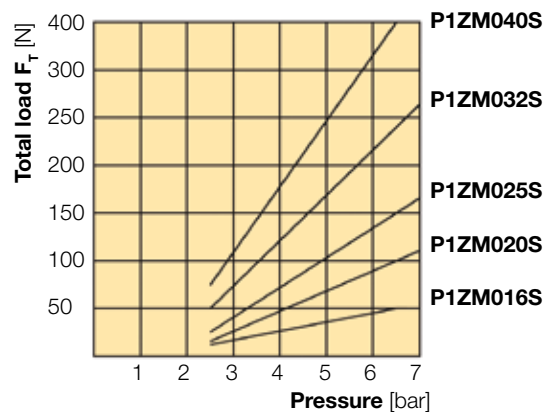
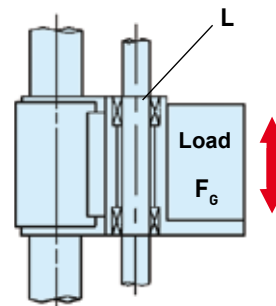

L = Weight of the external carriage  
 FG = Load  
 Ft = Total load = Load FG + Weight of the external carriage L + Force due to friction

**! Dynamic forces must not exceed the maximum magnetic coupling force!**

**Cushioning diagram**

If the permitted limit values are exceeded, additional shock absorbers should be fitted in the area of the centre of gravity.

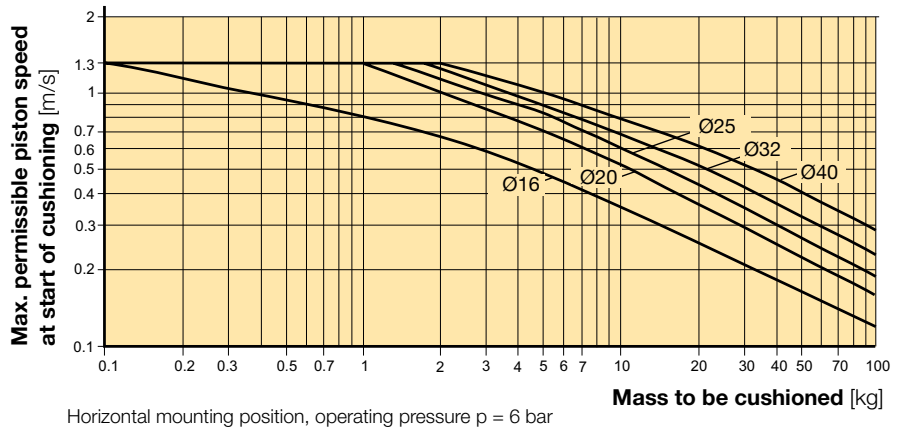

**Installation tips for use with external guides**

When stopping a load having a large inertia force at the stroke end, tilting of the carriage and damage to the bearings and cylinder barrel may occur (fig. left).

To prevent this, the force transmission should be realized at the middle axis of the cylinder.

The combination of the shock absorber with an end stop, can help to prevent the tilting of the carriage (fig. right).

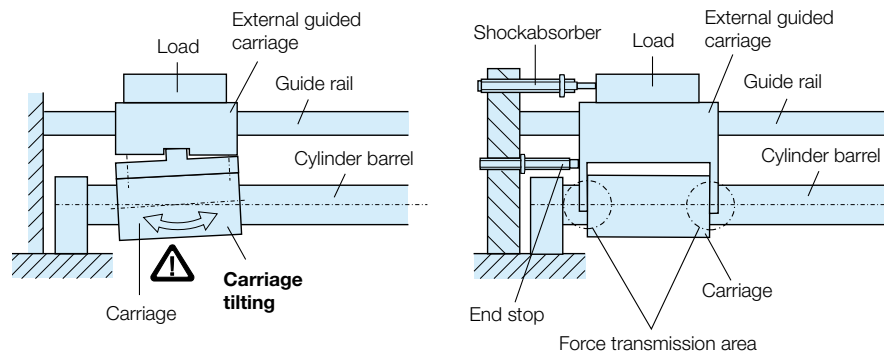



# P1Z Rodless Pneumatic Cylinders Magnetically Coupled

## Dimensions - Basic version

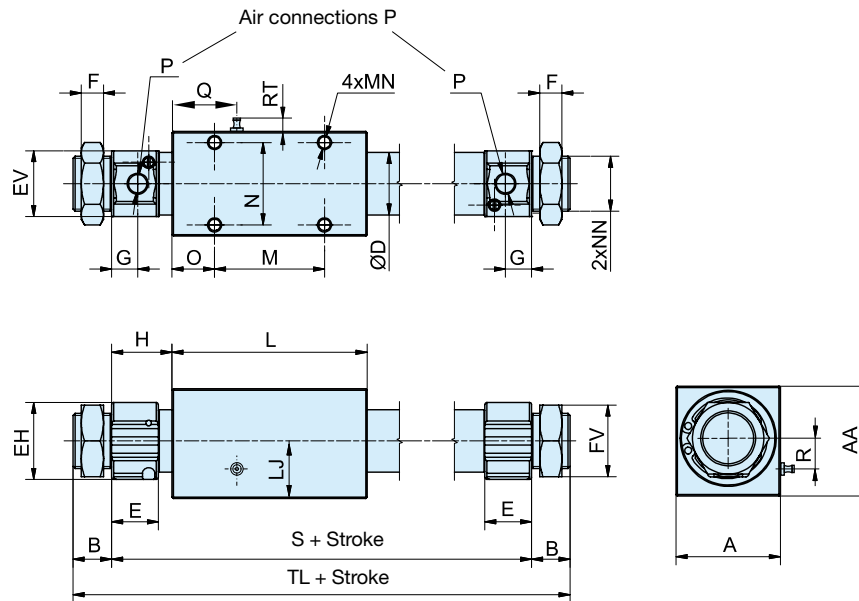

Ø [mm]	A	AA	B	ØD	E	EH	EV	F	FV	G	H	L	LJ	M	MN
16	32	34	10	18	14	18	18	4	14	5.5	18.5	61	16	34	M4 x 0.7 x 6
20	38	40	14	22.8	17	28	24	8	26	9.5	22	71	19	40	M5 x 0.8 x 8
25	48	48	16	27.8	17	34	30	8	32	9.5	22	76	24	50	M5 x 0.8 x 8
32	60	60	16	35	17	40	36	8	32	9.5	23	87	30	50	M6 x 1 x 10
40	70	70	16	43.0	21	48	45	10	41	11	29	92	35	60	M6 x 1 x 10

Ø [mm]	N	NN	O	P	Q	R	RT	S	TL
16	25	M10 x 1	13.5	M5 x 0.8	-	-	-	98	118
20	30	M20 x 1.5	15.5	G 1/8	-	-	-	115	143
25	30	M26 x 1.5	13	G 1/8	21	16	9	120	152
32	40	M26 x 1.5	18.5	G 1/8	-	-	-	133	165
40	40	M32 x 1.5	16	G 1/4	24	21	9	150	182

# P1Z Rodless Pneumatic Cylinders Magnetically Coupled

## Flange mounting

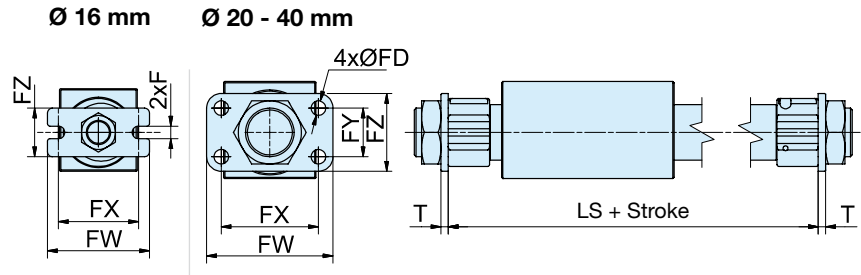

Ø [mm]	F	Ø FD	FW	FX	FY	FZ	T	LS	Order no.
16	5.2	-	42	33	-	20	2.3	92	<b>PDC15-FH*</b>
20	-	6	52	40	20	32	3	115	<b>PK1A20-FH*</b>
25	-	7	80	64	28	44	5	120	<b>PK1A25-FH*</b>
32	-	7	80	64	28	44	5	133	<b>PK1A25-FH*</b>
40	-	7	80	64	28	44	5	150	<b>PK1A40-FH*</b>

Material: galvanised steel  
 \* The mountings are supplied in pairs.

## Foot mounting

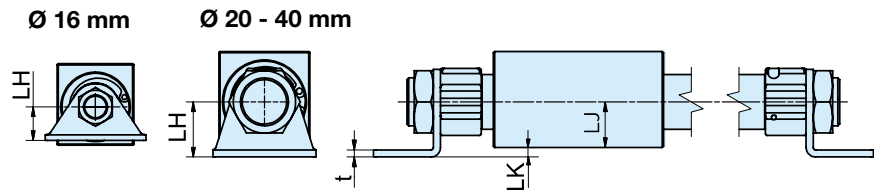

### Foot mounting outside



Ø 16 - 40 mm

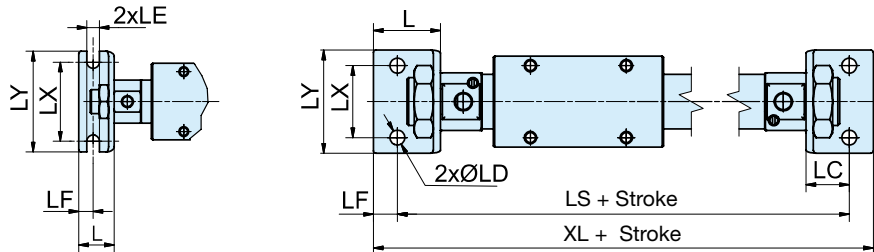

### Foot mounting inside



Only Ø 16 and 20 mm

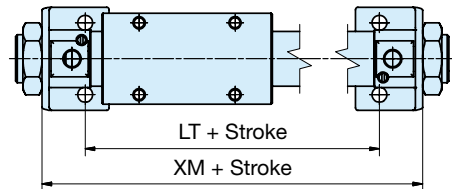

Material: galvanised steel  
 \* The mountings are supplied in pairs.

\*\* Inside foot mounting is not possible.

Ø [mm]	t	L	LC	ØLD	LE	LF	LH	LJ	LK	LX	LY	LS	LT	XL	XM	Order no.
16	2.3	14.8	8.8	-	5.2	6	14	16	-2	33	42	109.6	79	121.6	96.6	<b>PDC15-LB*</b>
20	3	28	18	6.2	-	10	23	19	4	30	43	151	85	171	121	<b>PK1A20-LB*</b>
25	3	35	23	7	-	12	30	24	6	46	62	166	**	222	**	<b>PK1A25-LB*</b>
32	3	35	23	7	-	12	30	30	0	46	62	179	**	203	**	<b>PK1A25-LB*</b>
40	3	36	24	7	-	12	30	35	5	46	62	198	**	254	**	<b>PK1A40-LB*</b>

# P1Z Rodless Pneumatic Cylinders Magnetically Coupled

## Order Instructions - Basic Cylinder - Series P1Z

Basic cylinder (15 digits)													With option (18 digits)				
<b>P</b>	<b>1</b>	<b>Z</b>	<b>M</b>	<b>0</b>	<b>1</b>	<b>6</b>	<b>S</b>	<b>A</b>	<b>N</b>	<b>0</b>	<b>8</b>	<b>5</b>	<b>0</b>	<b>W</b>	<b>F</b>	<b>M</b>	<b>N</b>

Piston diameter	
<b>016</b>	Ø 16 mm
<b>020</b>	Ø 20 mm
<b>025</b>	Ø 25 mm
<b>032</b>	Ø 32 mm
<b>040</b>	Ø 40 mm

End of stroke cushioning	
<b>A</b>	Pneumatically adjustable (Ø 16, 20, 25, 32 and 40 mm)

Stroke length	
max. stroke [mm]	Piston Ø [mm]
<b>1000</b>	Ø 16
<b>1500</b>	Ø 20
<b>2000</b>	Ø 25
<b>2000</b>	Ø 32
<b>2000</b>	Ø 40

Options	
<b>B</b>	without
<b>W</b>	with

Mountings	
<b>N</b>	without
<b>F</b>	Foot mounting
<b>L</b>	Flange mounting

Air supply port type	
<b>M</b>	Metric thread (Ø 16 mm)
<b>B</b>	G-thread (Ø 20 - 40 mm)
(Other types on request)	

**Order code examples:**

- **P1ZM016SAN0100B**      Ø 16 mm, stroke 100 mm, supplied with hexagonal nuts on each end cap.
- **P1ZM020SAN1000WFBN**      Ø 20 mm, stroke 1000 mm, with foot mounting at both end caps.

## P1Z Rodless Pneumatic Cylinders Magnetically Coupled

### P1Z Series - Guided Version

Ø 16 - 40 mm

The P1Z is a rodless pneumatic cylinder with guide. The piston and the guide carriage are equipped with ring magnets.

The motion is transmitted via the magnetic force between the piston and the guide carriage.

The guided version consists of a carriage fitted with 4 plain bearings, guided on 2 guide rods. The design provides high rigidity, accurate guidance and a non rotating movement.

#### Features:

- Double acting with guide
- Magnetically coupled without mechanical connection
- Mechanical protection in case of occasional overload due to magnetic uncoupling
- Piston chamber and Slide are pressure tight
- Pressure tight and leak free system
- Air connection at one end (option)
- End of stroke cushioning: with elastomeric bumpers (standard), with hydraulic shock absorbers (option)
- Position sensing: Al-profile rail for magnetic switches (option). Magnetic switches available as reed switches or as electronic sensors (option).

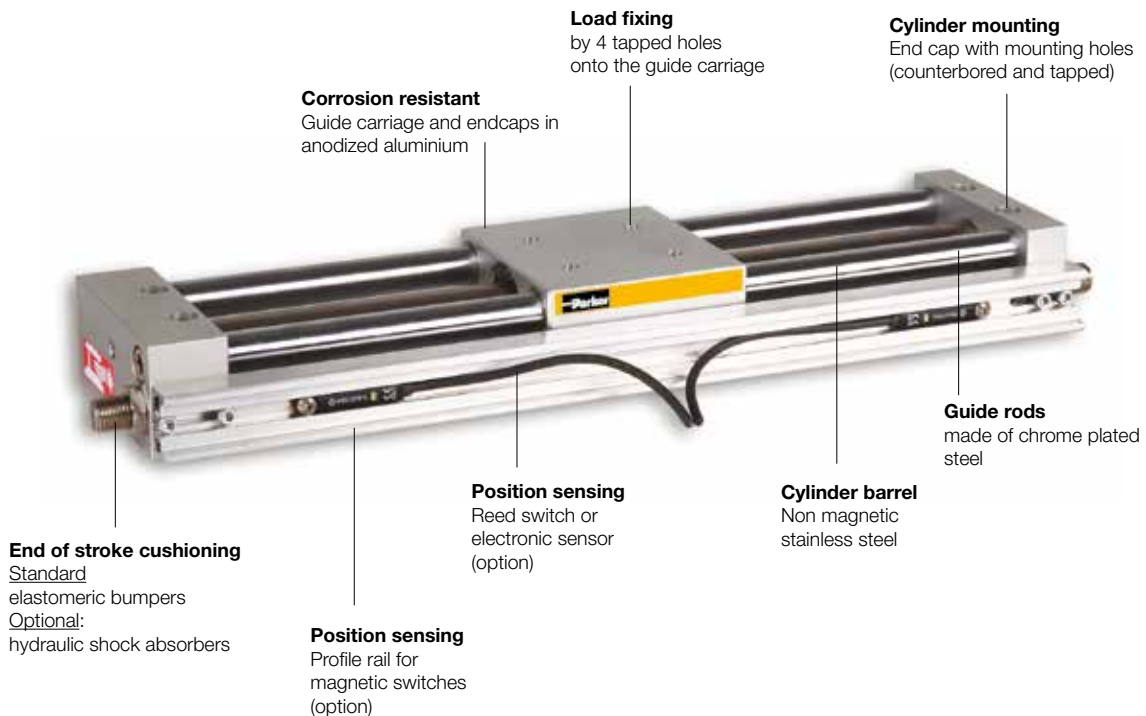
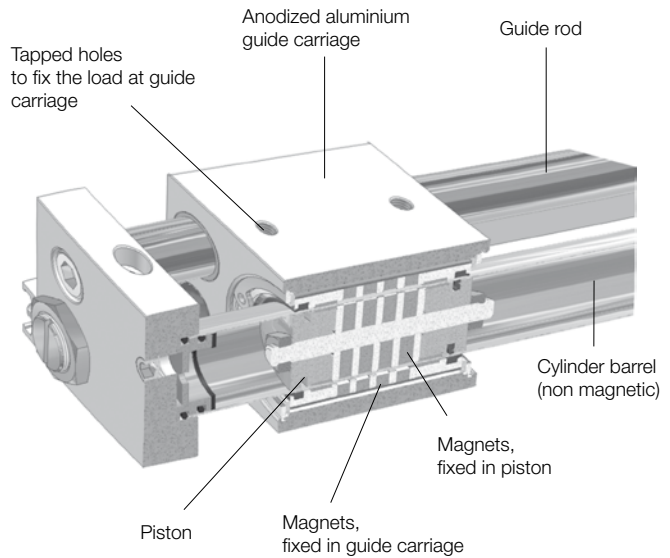

**Guided Version**

**Ø 16 - 40 mm**

**Air connection**



Guided version P1Z and air connection on both sides (standard)



Guided version P1Z and air connection at one end (option)

**End of stroke cushioning**

The end of stroke cushioning for light loads is provided by elastomeric bumpers (standard).

For medium and heavy loads hydraulic shock absorbers should be used (option).



Guided version P1Z and elastomeric bumpers (standard)



Guided version P1Z and hydraulic shock absorbers (option)

**Position sensing**

The guide carriage is fitted with a magnet for position sensing (standard)

An Al-profile rail for magnetic switches is available as an option. The rail is located on the same side as the elastomeric bumpers or the shock absorbers.

Reed switches or electronic sensors in several versions can be moved in the profile rail along the entire stroke length.



Guided version P1Z with magnet in the guide carriage for position sensing (standard).



Guided version P1Z and Al-profile rail for magnetic switches (option).



Guided version P1Z and Al-profile rail with 2 magnetic switches (option).

## P1Z Rodless Pneumatic Cylinders Magnetically Coupled

### Mounting and Technical Data

#### Guided Version

The loads can be fixed onto the guide carriage by 4 tapped holes.

Cylinder mounting provided with 4 tapped and counterbored holes. Additional mountings are not required.



#### Technical Data

Piston diameter Ø [mm]	16	20	25	32	40
Max. stroke length [mm]	750	1000	1500	1500	1500
Stroke tolerance [mm] up to 1000 mm	0/+1.5				
Stroke tolerance [mm] > 1000 mm	0/+2				
Temperature range [°C]	0 to 60				
Operating medium	Filtered compressed air, dry, lubricated or unlubricated * (other media on request)				
Air supply port size	M5	G1/8	G1/8	G1/8	G1/4
Max. magnetic coupling force [N]	157	236	383	703	942
Velocity range [m/s]	0.5 to 0.4				
Min. operating pressure [bar]	2.3	2			
Max. operating pressure [bar]	6.5	7			
Weight [kg]					
at 0 mm stroke	0.9	1.52	1.70	3.63	5.44
per 100 mm stroke	0.2	0.33	0.42	0.53	0.86

#### Materials

Cylinder barrel	Stainless steel
Carriage	Anodised aluminium
End cap	Anodised aluminium
Seals	NBR
Guide rods	Chrome plated steel

\* if external lubrication is added, this must always be continued.

# P1Z Rodless Pneumatic Cylinders Magnetically Coupled

## Loads, forces and moments Guided Version

### Forces [N]

Piston [mm]	16	20	25	32	40
Theoretical force at 6 bar [N]	120	188	295	483	754
Max. magnetic coupling force [N]	157	236	383	703	942

### Permissible lateral force, depending on the stroke length

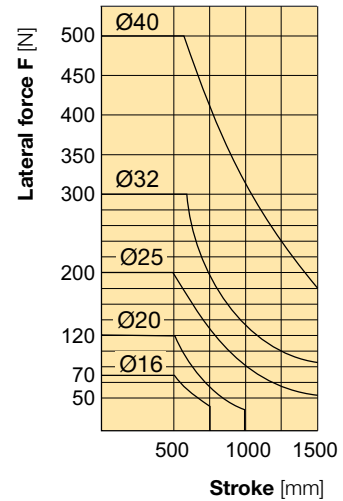
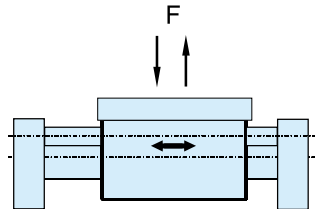

Ø [mm]	Max. Moment $M_x$ [Nm]	Max. Moment $M_y$ [Nm]	Max. Moment $M_z$ [Nm]
16	0.5	2.4	2.4
20	1.0	5.0	5.0
25	1.8	9.5	9.5
32	3.0	15.0	15.0
40	4.5	24.0	24.0

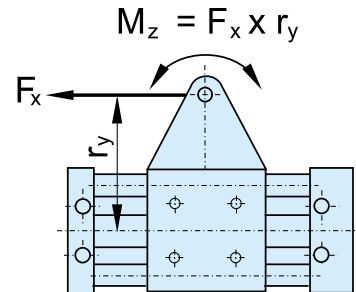
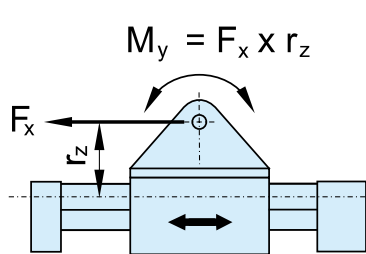
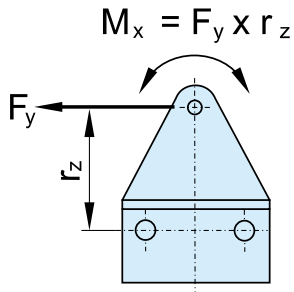

### Permissible moment $M_x$ depending on the stroke length

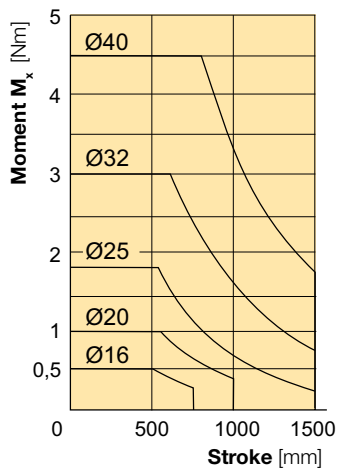

**Dynamic forces must not exceed the maximum magnetic coupling force!**

# P1Z Rodless Pneumatic Cylinders Magnetically Coupled

## Permissible axial load, vertical mounting

For vertical applications please refer to the values in the diagrams!

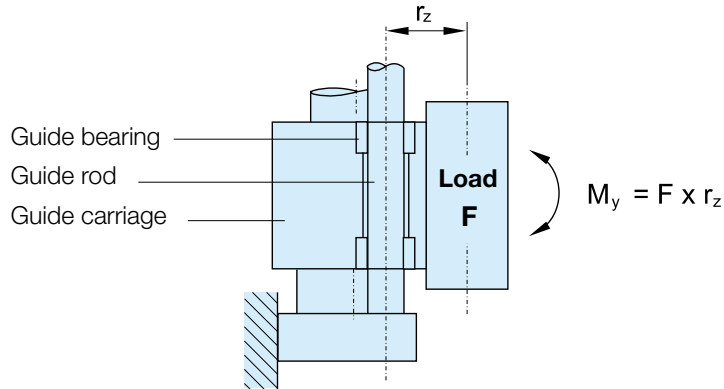

Cylinder Ø 16, 25, 40

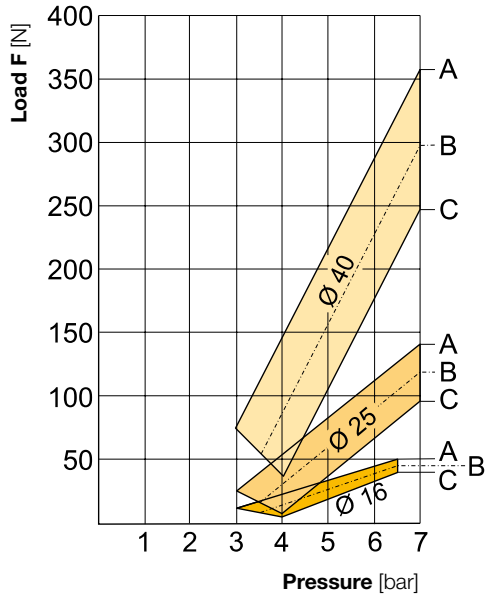

Cylinder Ø 20, 32

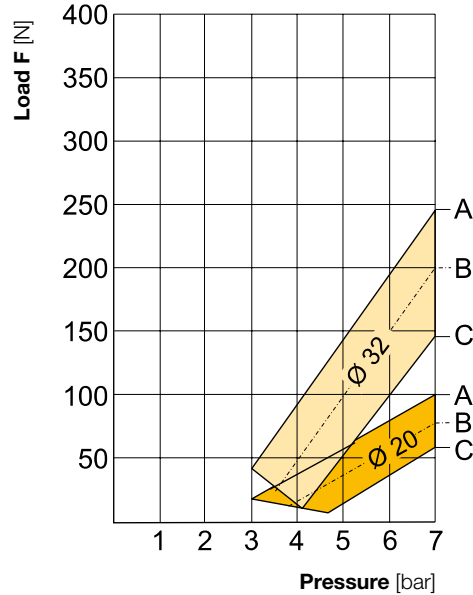

Ø [mm]	Max. Load F [N]	B Max. Moment $M_y / 2$ [Nm]	C Max. Moment $M_y$ [Nm]
16	50.0	1.2	2.4
20	100.0	2.5	5.0
25	140.0	4.75	9.5
32	240.0	7.5	15.0
40	360.0	12.0	24.0

A = curve at moment  $M_y = 0$

B = curve at moment  $M_y/2 =$  see column B

C = curve at moment  $M_{y \max.} =$  see column C



# P1Z Rodless Pneumatic Cylinders Magnetically Coupled

## Dimensions - Guided version

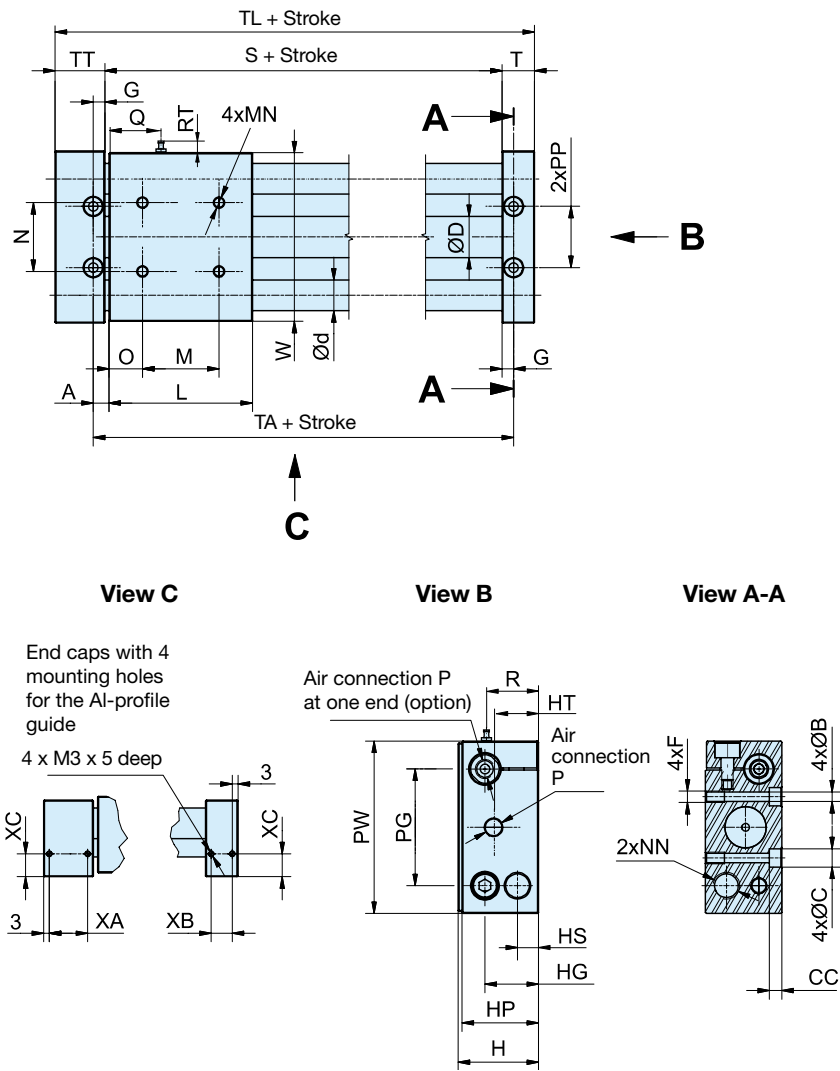

Ø [mm]	A	ØB	ØC	CC	ØD	Ød	F x depth	G	H	HG	HP	HS	HT	L	M	MN x depth
16	8	4.3	8	4.5	17.4	12	M5 x 10	6	34	25	33.5	12	21.5	65	34	M5 x 8
20	8	5.5	9.5	6.5	21.4	16	M6 x 10	6	42	28	40	12	23.5	75	40	M6 x 10
25	10	7	11	6.5	26.4	16	M8 x 10	8	54	32	52	40	24.5	80	40	M8 x 10
32	13.5	8.7	14	8	33.6	20	M10 x 15	10	66	46	64	20	41	91	60	M8 x 12
40	12.5	8.7	14	8	41.6	25	M10 x 15	10.5	76	50	74	56	28	95	65	M8 x 12

Ø [mm]	N	O	P	PG	PP	PW	Q	R	RT	S	T	TA	TL	TT	W	XA	XB	XC
16	30	15.5	M5	50	27	70	-	-	-	69	14	81	106	23	68	17	8	12
20	36	17.5	G1/8	61	32	90	-	-	-	79	17	91	122	26	88	20	11	12
25	70	20	G1/8	70	42	100	23	34	9	84	17	100	127	26	97	20	11	32
32	50	15.5	G1/8	86	50	122	-	-	-	97	20	117	145	28	118	22	14	12
40	105	15	G1/4	104	64	145	25.5	59	9	99	22	120	156	35	142	28	16	42

# P1Z Rodless Pneumatic Cylinders Magnetically Coupled

## Standard: Elastomeric bumpers

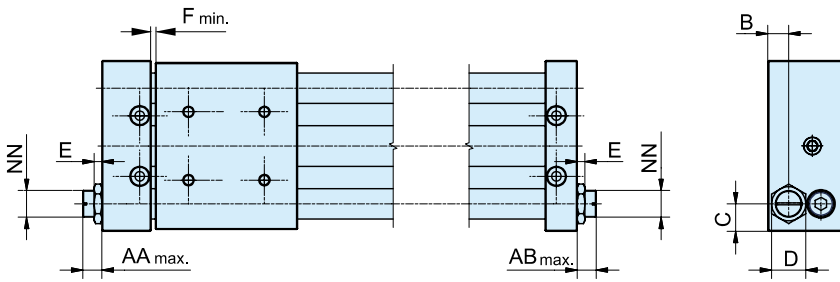

$\varnothing$ [mm]	$AA_{max.}$	$AB_{max.}$	B	C	D	E	$F_{min.}$	NN
16	13	13	12	10	14	4	2	M10X1
20	10	10	11	14.5	17	6	2	M14X1.5
25	11	20	40	15	17	6	2	M14x1.5
32	12	12	20	18	27	6	2,5	M20X1.5
40	11	11	56	20.5	27	6	2	M20x1.5

## Cushioning diagram for elastomeric bumpers

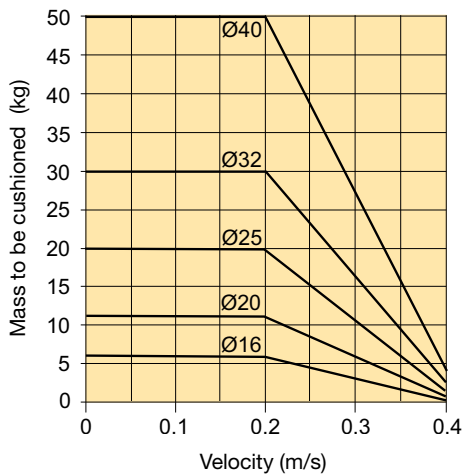

The diagram shows the capacities of the P1Z cylinders with elastomeric bumpers.

If the intersection between speed and mass is above the curves, it is imperative to use hydraulic shock absorbers to prevent cylinder damage.

### Example:

Cylinder  $\varnothing 32$  mm, at a velocity of 0.3 m/s with a mass of 25 kg choose hydraulic shock absorbers.

Cylinder  $\varnothing 20$  mm, at a velocity of 0.2 m/s with a mass of 10 kg choose the elastomeric bumpers.

**Option: Hydraulic shock absorbers**

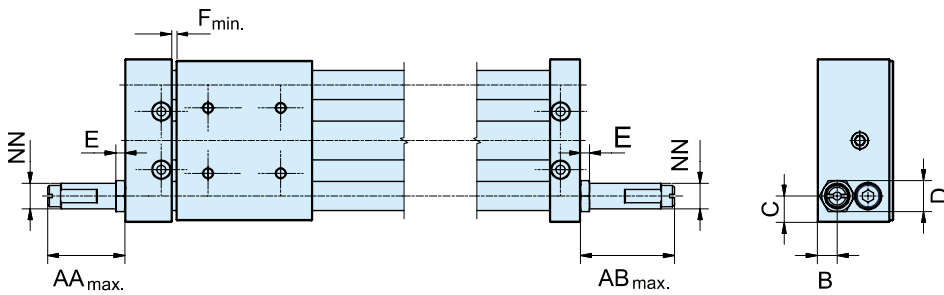

Ø [mm]	AA <sub>max.</sub>	AB <sub>max.</sub>	B	C	D	E	F <sub>min.</sub>	NN
16	18	27	12	10	12	4	2	M10X1
20	47	56	11	14.5	17	6	2	M14X1.5
25	47	56	40	15	17	6	2	M14x1.5
32	56	66	20	18	23	8	3.5	M20x1.5
40	51	64	56	20.5	23	8	2	M20x1.5

**Option: Al-profile rail for magnetic switches**

**Position sensing**

The rail is located on the same side as the end of stroke cushioning elements (Bumpers or shocks).

Reed switches or electronic sensors can be moved in the profile rail along the entire stroke length.



**Dimensions (Ø 16 - 40 mm)**

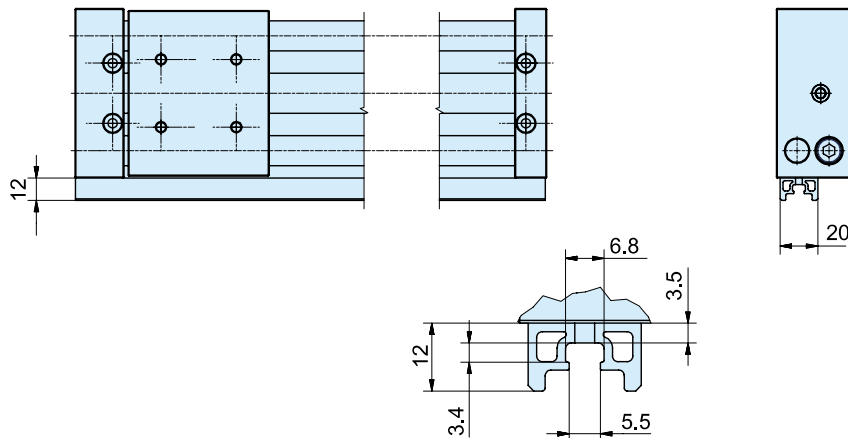

# P1Z Rodless Pneumatic Cylinders Magnetically Coupled

## Order Instructions - Guided version

Basic cylinder (15 digits)												With option (18 digits)					
P	1	Z	M	0	1	6	T	C	N	0	8	5	0	W	N	M	L

Piston diameter	
016	Ø 16 mm
020	Ø 20 mm
025	Ø 25 mm
032	Ø 32 mm
040	Ø 40 mm

Version	
G	Guided version and air connection on both sides
T	Guided version and air connection at one end

End of stroke cushioning	
C	with elastomeric bumpers
H	with two hydraulic shock absorbers

Stroke length	
max. stroke [mm]	piston Ø [mm]
750	Ø 16
1000	Ø 20
1500	Ø 25
1500	Ø 32
1500	Ø 40

Options	
B	without
W	with

Air supply port type	
M	Metric thread (Ø 16 mm)
B	G-thread (Ø 20 - 40 mm)
(Other types on request)	

Position sensing	
N	without
L	Al-profile without magnetic switch
S	2 Reed switches, 0.3 m with M8 connector, snap in
C	2 Reed switches, 3 m flying leads
K	2 Electronic sensors PNP 0.3 m with M8 connector, snap in
H	2 Electronic sensors PNP 3 m flying leads

### Order code examples:

- **P1ZM016TCN0100B** Cylinder guided version -Ø 16 mm, stroke 100 mm, with air connection at one end and elastomeric bumpers.
- **P1ZM020GHN1000WNBL** Cylinder guided version -Ø 20 mm, stroke 1000 mm, with air connection on both sides, with two hydraulic shock absorbers and profile rail for magnetic switches.

## Reed Switch and Electronic Sensor

### Series P8S



#### Magnetic Switches

Magnet switches are used for the contactless sensing of end or intermediate positions of the carriage.

The new generation of t-slot switches convince with easy mounting avoiding special tools and with a drop in mounting. Due to new electronics the hysteresis is very small and allows a very accurate switching point.

#### Electronic Sensor

This type of electronic sensor with PNP function provides a short circuit as well as a transient protection as standard. The new state of the art electronics inside can be used for endless lifetime. Especially if the application demand for high switching frequency is required.

#### Reed Switch

The 2-pole reed switch is a price attractive alternative while offering reliable and proven function for a lot of applications. An integrated LED shows the status of the switch visually.

Carriage speed and switching distance affect signal duration and should be considered in conjunction with the minimum reaction time of ancillary control equipment.

In accordance to this, the contact travel must be included in the calculation.

#### Technical Data

Magnetic sensor	P8S-GR
<b>Electrical Characteristics</b>	
Switching output / function	Reed / NO
Electric configuration	2-pole
Indicator LED yellow	yes
Operating voltage $U_b$	10 - 30 AC/DC
Ripple of $U_b$	$\leq 10\%$
Voltage drop	$\leq 3\text{ V}$
Continuous current	$\leq 100\text{ mA}$
Max. switching capacity	$\leq 6\text{ W}$
Switchable capacity load	100 nF
Switching frequency	$\leq 400\text{ Hz}$
Time delay before availability	1.5 / 0.5 ms
Switch point accuracy	$\leq 0.2\text{ mm}$
Switching distance	ca. 15 mm
Hysteresis	2 mm
EMC to EN 60947-5-2	yes
Lifetime	$\geq 40 \times 10^6$ cycles

#### Mechanical characteristics

Housing	PA12
Cable type	PUR / black
Cable cross section	2 x 0.14 mm <sup>2</sup>
Bending radius fixed installation	$\geq 20\text{ mm}$
Bending radius moving	$\geq 30\text{ mm}$

#### Shock resistance

Protection EN 60529	68 IP
Ambient temperature range	- 25 °C to + 80 °C
Vibration EN 60068-2-6 (G)	15, 11 ms, 10 up to 55 Hz, 1 mm
Permanent shock EN 60068-2-29 (G)	30, 11 ms, 1000 shocks per axis
Shock EN 60068-2-27	50, 11 ms

#### Technical Data

Magnetic sensor	P8S-GP
<b>Electrical Characteristics</b>	
Switching output / function	PNP / NO
Electric configuration	3-pole
Indicator LED yellow	yes
Operating voltage $U_b$	10 - 30 DC
Voltage drop	$\leq 2\text{ V}$
Power consumption unloaded $U_b = 24\text{ V}$	$\leq 10\text{ mA}$
Continuous current	$\leq 200\text{ mA}$
Switching frequency	$\leq 5000\text{ Hz}$
Time delay before availability	0.5 / 25 ms
Switch point accuracy	$\leq 0.2\text{ mm}$
Switching distance	ca. 15 mm
Hysteresis	2 mm
EMC to EN 60947-5-2	yes
Lifetime	unlimited
Short circuit protection	yes
Reverse polarity protection	yes
Power-up pulse Suppression	yes
Protection for inductive load	yes
ATEX certification	yes
Category	3D / 3G

#### Mechanical characteristics

Housing	PA12
Cable type	PUR / black
Cable cross section	2 x 0.14 mm <sup>2</sup>
Bending radius fixed installation	$\geq 20\text{ mm}$
Bending radius moving	$\geq 30\text{ mm}$

#### Shock resistance

Protection EN 60529	68 IP
Ambient temperature range	- 25 °C to + 80 °C
Vibration EN 60068-2-6 (G)	15, 11 ms, 10 up to 55 Hz, 1 mm
Permanent shock EN 60068-2-29 (G)	30, 11 ms, 1000 shocks per axis
Shock EN 60068-2-27 (G)	50, 11 ms

# P1Z Rodless Pneumatic Cylinders Magnetically Coupled

## Magnetic Switches

### Electric Service Life Protective Measures

The reed switches are sensitive to excessive currents and inductions. With high switching frequencies and inductive loads such as relays, solenoid valves or lifting magnets, service life will be greatly reduced.

With resistive and capacitive loads with high switch-on current, such as light bulbs, a protective resistor should be fitted. This also applies to long cable lengths and voltages over 100 V.

In the switching of inductive loads such as relays, solenoid valves and lifting magnets, voltage peaks (transients) are generated which must be suppressed by protective diodes, RC loops or varistors.

### Connection Examples

Load with protective circuits

- (a) Protective resistor for light bulb
- (b) Freewheel diode on inductivity
- (c) Varistor on inductivity
- (d) RC element on inductivity

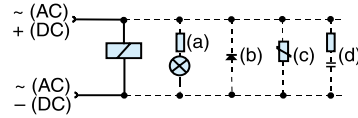

For the type P8S-GP, external protective circuits are not normally needed.

### Electrical Connection - Reed Switch

Normally open

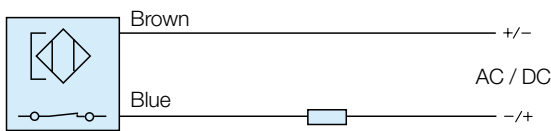

### Electrical Connection - Electronic Sensor PNP

Normally open

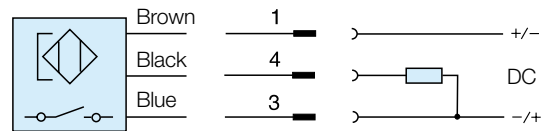

### Dimensions (mm)

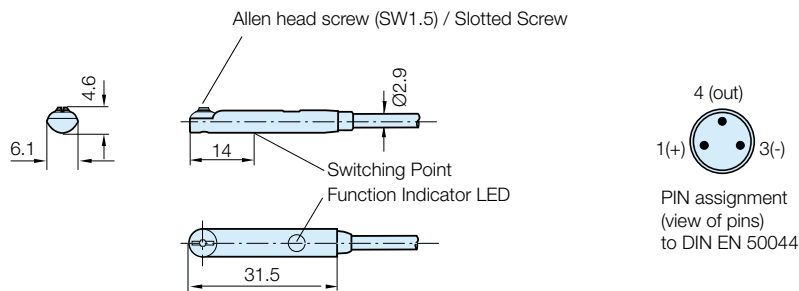

#### P8S-GRFAX, P8S-GPFAX cable with flying leads

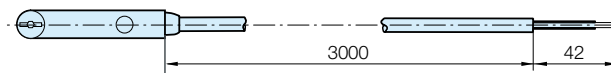

#### P8S-GRSHX, P8S-GPSHX cable with M8 snap in connector

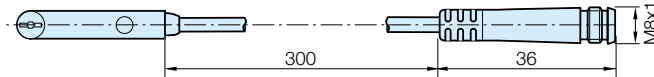

### Sensor Installation

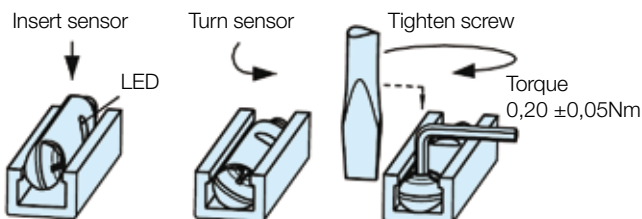

### Order number

	M8 Connector, snap in, 3-pole 0.3 m	FL flying leads 3 m
Reed NO (2-wire)	<b>P8S-GRSHX</b>	<b>P8S-GRFAX</b>
PNP NO	<b>P8S-GPSHX</b>	<b>P8S-GPFAX</b>

**Spare parts****Elastomeric bumpers**

(2 pieces)



Ø [mm]	Order no.
16	<b>14332</b>
20	<b>14333</b>
25	
32	<b>14334</b>
40	

**Screw in one-way flow control valve with exhaust restrictor**

(1 piece)



Ø [mm]	Connection	Order no.
16	M5	<b>KT0433</b>
20		
25	G 1/8	<b>KW0520</b>
32		
40	G 1/4	<b>KW0521</b>

# Parker Worldwide

## Europe, Middle East, Africa

**AE – United Arab Emirates,**  
Dubai

Tel: +971 4 8127100  
parker.me@parker.com

**AT – Austria,** Wiener Neustadt

Tel: +43 (0)2622 23501-0  
parker.austria@parker.com

**AT – Eastern Europe,** Wiener  
Neustadt

Tel: +43 (0)2622 23501 900  
parker.easteurope@parker.com

**AZ – Azerbaijan,** Baku

Tel: +994 50 2233 458  
parker.azerbaijan@parker.com

**BE/LU – Belgium,** Nivelles

Tel: +32 (0)67 280 900  
parker.belgium@parker.com

**BG – Bulgaria,** Sofia

Tel: +359 2 980 1344  
parker.bulgaria@parker.com

**BY – Belarus,** Minsk

Tel: +375 17 209 9399  
parker.belarus@parker.com

**CH – Switzerland,** Etoy

Tel: +41 (0)21 821 87 00  
parker.switzerland@parker.com

**CZ – Czech Republic,** Klecany

Tel: +420 284 083 111  
parker.czechrepublic@parker.com

**DE – Germany,** Kaarst

Tel: +49 (0)2131 4016 0  
parker.germany@parker.com

**DK – Denmark,** Ballerup

Tel: +45 43 56 04 00  
parker.denmark@parker.com

**ES – Spain,** Madrid

Tel: +34 902 330 001  
parker.spain@parker.com

**FI – Finland,** Vantaa

Tel: +358 (0)20 753 2500  
parker.finland@parker.com

**FR – France,** Contamine s/Arve

Tel: +33 (0)4 50 25 80 25  
parker.france@parker.com

**GR – Greece,** Athens

Tel: +30 210 933 6450  
parker.greece@parker.com

**HU – Hungary,** Budaörs

Tel: +36 23 885 470  
parker.hungary@parker.com

**IE – Ireland,** Dublin

Tel: +353 (0)1 466 6370  
parker.ireland@parker.com

**IT – Italy,** Corsico (MI)

Tel: +39 02 45 19 21  
parker.italy@parker.com

**KZ – Kazakhstan,** Almaty

Tel: +7 7273 561 000  
parker.easteurope@parker.com

**NL – The Netherlands,** Oldenzaal

Tel: +31 (0)541 585 000  
parker.nl@parker.com

**NO – Norway,** Asker

Tel: +47 66 75 34 00  
parker.norway@parker.com

**PL – Poland,** Warsaw

Tel: +48 (0)22 573 24 00  
parker.poland@parker.com

**PT – Portugal,** Leca da Palmeira

Tel: +351 22 999 7360  
parker.portugal@parker.com

**RO – Romania,** Bucharest

Tel: +40 21 252 1382  
parker.romania@parker.com

**RU – Russia,** Moscow

Tel: +7 495 645-2156  
parker.russia@parker.com

**SE – Sweden,** Spånga

Tel: +46 (0)8 59 79 50 00  
parker.sweden@parker.com

**SL – Slovenia,** Novo Mesto

Tel: +386 7 337 6650  
parker.slovenia@parker.com

**TR – Turkey,** Istanbul

Tel: +90 216 4997081  
parker.turkey@parker.com

**UA – Ukraine,** Kiev

Tel: +380 44 494 2731  
parker.poland@parker.com

**UK – United Kingdom,** Warwick

Tel: +44 (0)1926 317 878  
parker.uk@parker.com

**ZA – South Africa,** Kempton Park

Tel: +27 (0)11 961 0700  
parker.southafrica@parker.com

## North America

**CA – Canada,** Milton, Ontario

Tel: +1 905 693 3000

**US – USA,** Cleveland

Tel: +1 216 896 3000

## Asia Pacific

**AU – Australia,** Castle Hill

Tel: +61 (0)2-9634 7777

**CN – China,** Shanghai

Tel: +86 21 2899 5000

**HK – Hong Kong**

Tel: +852 2428 8008

**IN – India,** Mumbai

Tel: +91 22 6513 7081-85

**JP – Japan,** Tokyo

Tel: +81 (0)3 6408 3901

**KR – South Korea,** Seoul

Tel: +82 2 559 0400

**MY – Malaysia,** Shah Alam

Tel: +60 3 7849 0800

**NZ – New Zealand,** Mt Wellington

Tel: +64 9 574 1744

**SG – Singapore**

Tel: +65 6887 6300

**TH – Thailand,** Bangkok

Tel: +662 186 7000

**TW – Taiwan,** Taipei

Tel: +886 2 2298 8987

## South America

**AR – Argentina,** Buenos Aires

Tel: +54 3327 44 4129

**BR – Brazil,** Sao Jose dos Campos

Tel: +55 12 4009 3500

**CL – Chile,** Santiago

Tel: +562 2303 9640

**MX – Mexico,** Toluca

Tel: +52 72 2275 4200

European Product Information Centre

Free phone: 00 800 27 27 5374

(from AT, BE, CH, CZ, DE, DK, EE, ES, FI,  
FR, IE, IL, IS, IT, LU, MT, NL, NO, PL, PT, RU,  
SE, SK, UK, ZA)

### Parker Hannifin Ltd.

Tachbrook Park Drive

Tachbrook Park,

Warwick, CV34 6TU

United Kingdom

Tel.: +44 (0) 1926 317 878

Fax: +44 (0) 1926 317 855

parker.uk@parker.com

www.parker.com

